

Gocator 2D

Smart Cameras

powered by **GoPXL** and **Deep Edge AI***

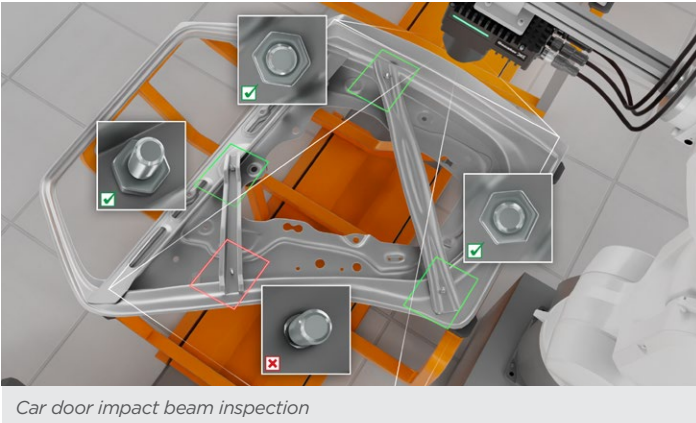

Car door impact beam inspection

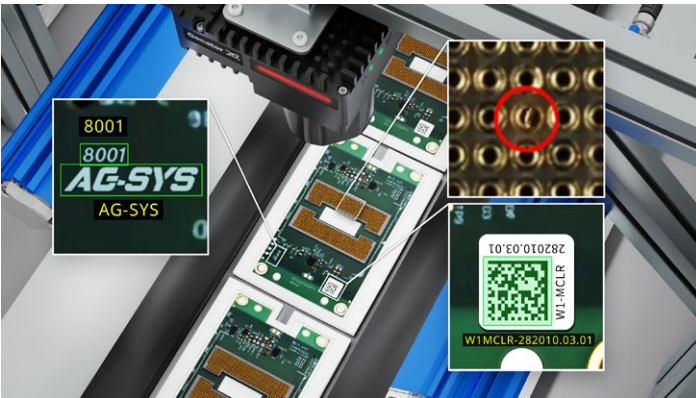

PCB Socket Inspection with Data Matrix Reading and OCR

Gocator 2D Smart Cameras provide a complete solution for industrial 2D measurement and inspection. Built on LMI's proven smart sensor platform, they combine high-resolution imaging, integrated lighting control, **deep edge AI*** (deep learning-powered intelligence executed on-device), and intuitive GoPXL™ software—delivering fast, accurate inspection without PCs or cloud infrastructure for demanding factory automation applications.

- **High-speed imaging:** Up to 84 FPS global shutter capture for fast-moving parts and short-exposure inspections
- **High-performance processing:** NVIDIA® Jetson™ Orin NX GPU and CPU share distributed inspection tasks including calibration, transformation, inspection logic, communication, and on-device AI training and inference
- **Integrated inspection toolset:** Rules-based alignment, edge, blob, barcode, and dimensioning tools plus AI anomaly detection, image classification, OCR, and feature detection
- **Integrated lighting control:** Native trigger, strobe, and overdrive control for RMX140 ring lights and LSR300 bar lights
- **Rugged industrial design:** IP67 housing with C-mount lens support for flexible field-of-view configuration



HIGH-SPEED, HIGH-RESOLUTION

Global shutter imaging up to 84 FPS captures parts in motion with short exposures—supporting defect detection, calibrated measurement in real-world units, and reliable code/OCR reading without motion blur.

NVIDIA-POWERED EDGE AI

The powerful Jetson Orin NX processor runs training and inference on the device using real production data—low latency, fast iteration, and factory-local operation with no cloud dependency or data egress.

SCALABLE WEB-BASED VISION SOFTWARE

GoPXL provides a web UI and GoHMI to configure, validate, and run inspections in one environment. Engineers manage inspection logic, model training, and system behavior without leaving the application—supporting consistent setup and scalable deployment across lines and facilities.

PYTHON-CUSTOMIZABLE

Extend workflows with Python, OpenCV pipelines, and third-party models—combining no-code build speed with full programmatic control as requirements evolve.

GOCATOR 2D SMART CAMERAS	1050-M		1050-C		1120-M		1120-C	
Image Type	Mono		Color		Mono		Color	
Resolution (pixels)	5 MP (2464 × 2064)				12 MP (4128 × 3008)			
Frames per Second (Burst, no processing)	84 fps				41 fps			
Sensor Type	1/1.8" CMOS, global shutter				1/1.1" CMOS, global shutter			
Sensor Properties	8.9 mm diagonal, 2.74 × 2.74 μm				14.0 mm diagonal, 2.74 × 2.74 μm			
Lens Mount	C-mount							
Non-volatile Memory	88 GB							
Application Memory	15 GB							
Indicator LEDs	Power and network LED							
Light Control	External lights using I/O connector							
Network	Gigabit Ethernet (10/100/1000 Mbps)							
Alignment and Status I/O	2 x input, 2 x output (opto-isolated)							
Trigger and Strobe	1 x Trigger, 1 x Strobe							
Industrial M12 Connectors	Power, I/O, Ethernet							
Protection	IP67 with C-mount lens cover							
Power	+24 VDC (camera only, 48 W; with RMX140 light, 168 W)							
Dimensions (L × W × H)	49.3 × 72 × 111.75 mm							
Dimension with lens cover (L × W × H)	102 × 72 × 111.75 mm				122.4 × 72 × 111.75 mm			
Camera Weight (without lens/cover)	650 g				650 g			
Lens Cover Weight	160 g				202 g			

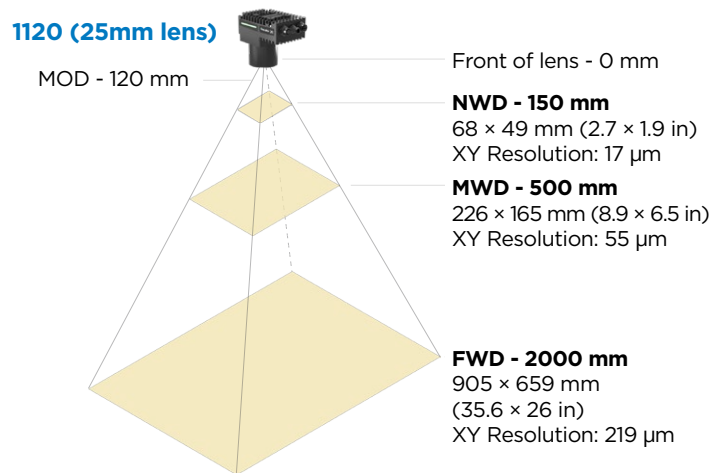
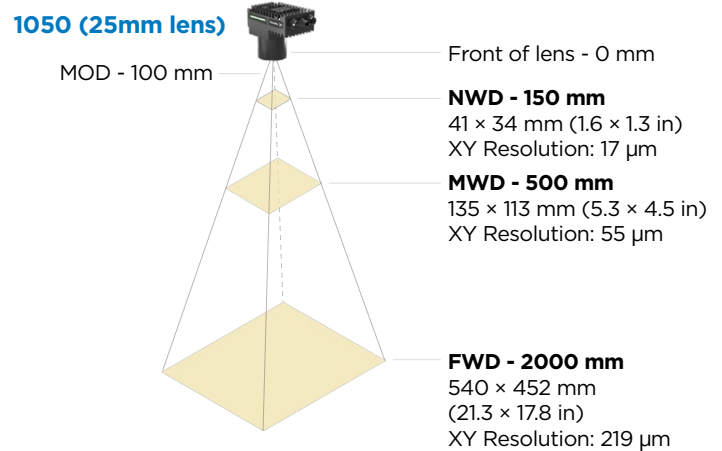
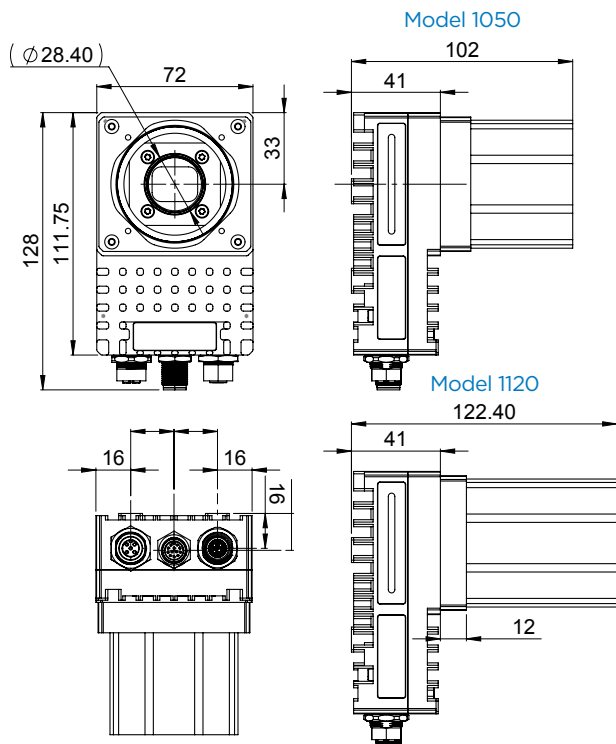
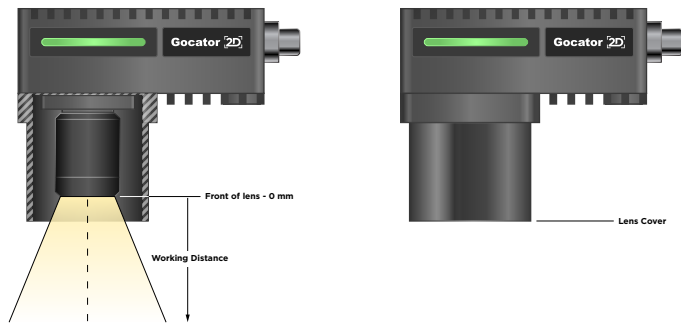

MOD = Minimum Object Distance; **NWD** = Near Working Distance
MWD = Mid Working Distance; **FWD** = Far Working Distance
 FWD is not the maximum distance the camera can focus at, the FOV continues past this point.