

# VENUS2 GigE Cameras

## User Manual

All rights reserved. No parts of this manual may be used or reproduced, in any forms or by any means, without prior written permission of China Daheng Group, Inc. Beijing Image Vision Technology Branch.

The right is also reserved to modify or change any parts of this manual in the future without prior notification.

All other trademarks are the properties of their respective owners.

© 2026 China Daheng Group, Inc. Beijing Image Vision Technology Branch

Web: [www.daheng-imaging.com/en](http://www.daheng-imaging.com/en)

Sales Email: [isales@daheng-imaging.com](mailto:isales@daheng-imaging.com)

Sales Tel: +86 10 8282 8878-8081

Support Email: [isupport@daheng-imaging.com](mailto:isupport@daheng-imaging.com)

# Preface

We really appreciate your choosing of DAHENG IMAGING products.

The VENUS2 GigE camera is DAHENG IMAGING's mature area scan industry camera. The VENUS2 cameras are the second generation of VENUS cameras, which provide more features and improved structures, featuring high resolution, high definition, low noise, small housing and extremely low power consumption. The camera is equipped with standard GigE interface, which is easy to install and use.

The VENUS2 GigE camera is especially suitable for machine vision applications such as industrial inspection, medical, scientific research, education and so on.

This manual describes in detail on how to install and use the VENUS2 GigE cameras.

# Contents

<b>1. Introduction</b> .....	<b>1</b>
1.1. Series Introduction .....	1
1.2. Naming Rules.....	1
1.3. Standards.....	1
1.4. Document, CAD/Technical Drawing and Software Downloads .....	1
<b>2. Precautions</b> .....	<b>2</b>
2.1. Safety Claim .....	2
2.2. Safety Instruction.....	2
2.3. Guidelines for Avoiding EMI and ESD.....	3
2.4. Environmental Requirements .....	3
2.5. Camera Mechanical Installation Precautions.....	4
2.6. Certification and Declaration .....	4
<b>3. Installation</b> .....	<b>5</b>
3.1. Host Preparation .....	5
3.1.1. Software Package .....	5
3.1.2. User Software Interface.....	5
3.2. Camera Power .....	7
3.3. Camera Driver Installation.....	7
3.3.1. System Requirements .....	7
3.3.2. Driver Installation.....	7
3.4. Camera IP Configuration .....	8
3.5. Open Device and Start Acquisition.....	8
3.6. Hardware System and Installation.....	9
3.6.1. All-in-one Vertical FPC Camera's Hardware Composition .....	9
3.6.2. Split Vertical FPC Camera's Hardware Composition.....	10
<b>4. General Specifications</b> .....	<b>12</b>
4.1. Explanation of Important Parameters .....	12
4.1.1. About Spectral Response.....	12
4.2. VE2S-G-P Series .....	12
4.2.1. VE2S-042-121GM/C-P .....	12
4.2.2. VE2S-161-75GM/C-P .....	14
4.2.3. VE2S-303-37GM/C-P.....	15
4.2.4. VE2S-501-23GM/C-P.....	17
4.2.5. VE2S-630-18GM/C-P .....	18
<b>5. Dimensions</b> .....	<b>20</b>

5.1. Camera Dimensions .....	20
5.2. Optical Interface .....	21
5.3. Tripod Adapter Dimensions .....	21
<b>6. Filters and Lenses .....</b>	<b>23</b>
6.1. Filters .....	23
6.2. Lens Selection Reference .....	24
6.2.1. HN-2M Series Prime Lenses .....	25
6.2.2. HN-5M Series Prime Lenses .....	25
6.2.3. HN-6M Series Prime Lenses .....	25
6.2.4. HN-20M Series Prime Lenses .....	26
6.2.5. HN-P-6M Series Prime Lenses .....	26
6.2.6. HN-P-10M Series Prime Lenses .....	27
6.2.7. HN-P-20M Series Prime Lenses .....	27
6.2.8. HN-P-25M Series Prime Lenses .....	27
<b>7. Electrical Interface .....</b>	<b>28</b>
7.1. LED Light .....	28
7.2. Ethernet Port .....	28
7.2.1. Standard RJ45 Jack .....	29
7.2.2. FPC Interface .....	29
7.3. I/O Port .....	30
7.3.1. I/O Connector Pin Definition .....	30
7.3.2. I/O Electrical Features .....	30
7.3.2.1. Line0 (Opto-isolated Input) Circuit .....	30
7.3.2.2. Line1 (Opto-isolated Output) Circuit .....	32
7.3.2.3. Line 2 (Bidirectional) Circuit .....	34
7.3.2.3.1. Line2 is Configured as Input .....	34
7.3.2.3.2. Line2 is Configured as Output .....	36
<b>8. Features .....</b>	<b>38</b>
8.1. I/O Control .....	38
8.1.1. Input Mode Operation .....	38
8.1.2. Output Mode Operation .....	39
8.1.3. Read the LineStatus .....	44
8.2. Image Acquisition Control .....	44
8.2.1. Acquisition Start and Stop .....	44
8.2.1.1. Acquisition Start .....	44
8.2.1.2. Acquisition Stop .....	45
8.2.2. Acquisition Mode .....	47
8.2.3. Trigger Type Selection .....	48
8.2.4. Switching Trigger Mode .....	49

8.2.5. Continuous Mode and Configuration.....	50
8.2.6. Acquisition Burst Mode.....	50
8.2.7. Software Trigger Acquisition and Configuration.....	51
8.2.8. Action Acquisition and Configuration .....	52
8.2.8.1. Action .....	52
8.2.8.2. Scheduled Action .....	53
8.2.8.3. Acquisition and Reception .....	54
8.2.9. Precision Time Protocol (PTP).....	55
8.2.9.1. Enable PTP.....	55
8.2.9.2. Checking the Status of the PTP Synchronization .....	55
8.2.9.3. PTP Status.....	56
8.2.9.4. Announce Receipt Timeout .....	57
8.2.9.5. PTP Data Latch.....	57
8.2.10. Hardware Trigger Acquisition and Configuration .....	57
8.2.11. Overlapping Exposure and Non-overlapping Exposure.....	58
8.2.12. Set Exposure .....	60
8.2.12.1. Set Exposure Mode .....	60
8.2.12.2. Set Exposure Value .....	62
8.2.12.3. Exposure Time Mode.....	64
8.2.12.4. Set Exposure Time .....	64
8.2.13. Exposure Delay .....	65
<b>8.3. Basic Features .....</b>	<b>66</b>
8.3.1. Gain .....	66
8.3.2. Pixel Format.....	67
8.3.3. ROI.....	71
8.3.4. Auto Exposure / Auto Gain.....	72
8.3.4.1. ROI Setting of Auto Exposure / Auto Gain .....	72
8.3.4.2. Auto Gain .....	73
8.3.4.3. Auto Exposure .....	73
8.3.5. Test Pattern .....	74
8.3.6. User Set Control .....	75
8.3.7. Device User ID .....	78
8.3.8. Timestamp.....	78
8.3.9. Binning.....	79
8.3.10. Decimation.....	81
8.3.11. Reverse X and Reverse Y .....	83
8.3.12. Digital Shift.....	85
8.3.13. Acquisition Status .....	86
8.3.14. Black Level and Auto Black Level .....	87
8.3.14.1. Black Level.....	87
8.3.14.2. Auto Black Level .....	87

8.3.15. Remove Parameter Limits.....	87
8.3.16. User Data Area.....	88
8.3.17. Timer.....	88
8.3.18. Counter.....	89
<b>8.4. Image Processing.....</b>	<b>90</b>
8.4.1. Light Source Preset.....	90
8.4.2. Auto White Balance.....	91
8.4.2.1. Auto White Balance ROI.....	91
8.4.2.2. Auto White Balance Adjustment.....	92
8.4.3. Color Transformation Control.....	92
8.4.4. Saturation.....	94
8.4.5. Gamma.....	95
8.4.6. Sharpness.....	96
8.4.7. Flat Field Correction.....	96
8.4.7.1. FFC Coefficient Calculation and Preview.....	97
8.4.7.2. Read/Save Coefficient.....	98
8.4.7.3. Load/Save File.....	99
8.4.8. Lookup Table.....	99
8.4.9. HDR.....	100
8.4.10. Noise Reduction.....	100
8.4.11. Hue.....	101
8.4.12. Contrast.....	102
8.4.13. Brightness.....	102
<b>8.5. Image Transmission.....</b>	<b>103</b>
8.5.1. Calculate Frame Rate.....	103
8.5.2. Maximum Allowable Frame Rate.....	104
8.5.3. Stream Channel Packet Size.....	106
8.5.4. Stream Channel Packet Delay.....	106
8.5.5. Bandwidth Reserve.....	107
8.5.6. Transfer Control.....	108
8.5.7. Frame Store Control.....	108
<b>8.6. Events.....</b>	<b>108</b>
8.6.1. ExposureEnd Event.....	110
8.6.2. BlockDiscard Event.....	110
8.6.3. BlockNotEmpty Event.....	110
8.6.4. FrameStartOvertrigger Event.....	110
8.6.5. EventOverrun Event.....	110
8.6.6. FrameBurstStartOvertrigger Event.....	110
8.6.7. FrameStartWait Event.....	111
8.6.8. FrameBurstStartWait Event.....	111

8.6.9. ActionLate Event .....	111
<b>9. Software Tools .....</b>	<b>112</b>
9.1. GigE IP Configurator .....	112
9.2. Frame Rate Calculation Tool.....	116
9.3. LUT Create Tool.....	117
9.3.1. GUI.....	117
9.3.2. User Guide.....	118
9.3.2.1. User Case .....	118
9.3.2.2. Select Base LUT .....	119
9.3.2.3. Auto Create LUT .....	121
9.3.2.4. Save LUT .....	121
9.3.2.5. Read LUT.....	121
9.3.3. Precautions.....	122
9.3.3.1. Read From Device .....	122
9.3.3.2. Write To Device .....	122
9.3.3.3. Directory Structure .....	122
9.4. Flat Field Correction Plugin .....	122
9.4.1. GUI.....	122
9.4.2. User Guide.....	123
9.4.2.1. FFC Execution Steps.....	123
9.4.2.2. Acquisition of Bright Field Images .....	124
9.4.2.3. Execute FFC .....	124
9.4.2.4. Read FFC Data from Device / Write FFC Data to Device.....	124
9.4.2.5. Load FFC Data from File / Save FFC Data to File .....	124
9.4.3. Precautions.....	125
9.4.3.1. FFC is not Supported.....	125
9.5. Static Defect Correction Plugin.....	125
9.5.1. Static Defect Correction Steps .....	128
9.5.2. Acquisition Images .....	128
9.5.3. Static Defect Correction.....	129
9.5.4. How to Use Defect Pixel Data File .....	129
9.6. Action Command Window .....	129
<b>10. FAQ .....</b>	<b>132</b>
<b>11. Revision History .....</b>	<b>134</b>
<b>12. Contact Us .....</b>	<b>135</b>
12.1. Contact Sales .....	135
12.2. Contact Support .....	135

# 1. Introduction

## 1.1. Series Introduction

The VENUS2 GigE camera is DAHENG IMAGING's mature area scan industry camera, featuring outstanding performance, powerful features, small size, outstanding price/performance ratio and ease of use. The VENUS2 GigE cameras are available in a variety of resolutions and frame rates, and are available with CMOS sensors from leading chip manufacturers.

The VENUS2 GigE camera transmits image data through the GigE interface and is equipped with data transmission cables of various lengths. It can secure the reliability of cameras deployed in harsh industrial environments, offering a highly reliable and cost-effective industrial digital camera solution. This product is suitable for industrial inspection, medical, scientific research, education and so on.

## 1.2. Naming Rules

Details of the VENUS2 GigE camera are given in the general specifications below. Each camera model name is determined by its sensor's maximum resolution, maximum frame rate at maximum resolution, the color/monochrome type of the sensor, etc.

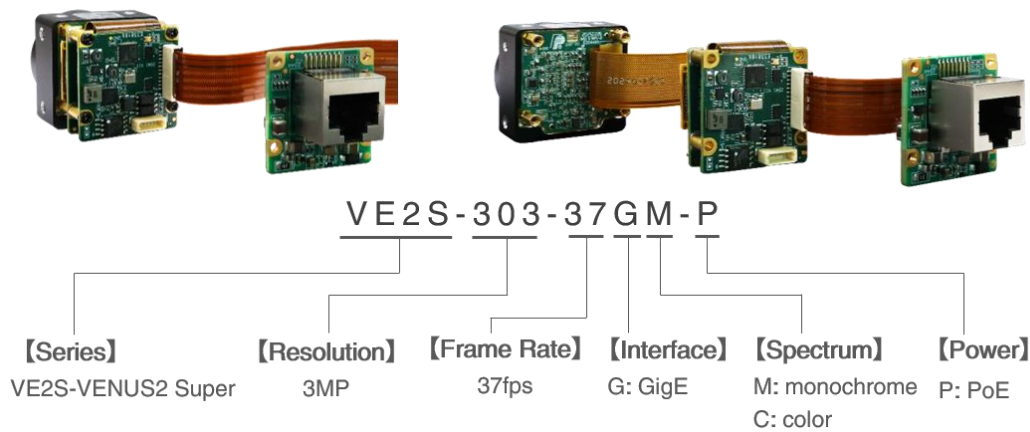

Figure 1-1 Naming rules

## 1.3. Standards

The camera follows the GigE Vision 1.2 standard, the GEN<i>CAM3.0 standard and the IEEE802.3af standard.

## 1.4. Document, CAD/Technical Drawing and Software Downloads



Product related document, CAD/Technical drawing and software can be downloaded from the [Downloads](#) of DAHENG IMAGING website.

## 2. Precautions



### 2.1. Safety Claim

Before installing and using DAHENG IMAGING products, please carefully read this manual and strictly comply with the usage requirements. And ensure to use the product in specified conditions, otherwise it may cause equipment malfunction. Our company will not bear any legal responsibility for any damage or injury caused by improper use of this product and disregard of safety instructions.

The symbols that may be found in this document are defined as follows:

Symbol	Description
	Note: Provides additional information to emphasize or supplement important points of the main text
	Caution: Indicates a potentially hazardous situation which, if not avoided, could result in equipment damage, data loss, performance degradation, or unexpected results
	Warning: Indicates a potential risk that, if not avoided, could result in injury accidents, equipment damage, or business interruption
	Danger: Indicates a hazard with a high level of risk, which if not avoided, will result in death or serious injury

### 2.2. Safety Instruction

Usage		
 <b>Warning</b>	<ol style="list-style-type: none"> <li>Do not install and operate the product in extreme environments with vibration, high temperature, humidity, dust, strong magnetic fields, explosive/corrosive smoke or gases, as it may damage the camera, cause a fire or electric shock.</li> <li>Do not aim at the product with high intensity light sources directly, as it may damage the sensor.</li> <li>If the device damaged, emits smoke, odor or noise, please turn off the power and unplug the power cord immediately, and contact our technical support engineer.</li> <li>Unauthorized disassembly, repair, or modification of products is prohibited as it may damage the camera or cause a risk of electric shock.</li> <li>In the use of the device, you must be in strict compliance with the electrical safety regulations of the nation and region.</li> <li>Please use the power supply provided by reputable manufacturers that meets the camera power limit requirements, otherwise, it will damage the camera.</li> </ol>	
	 <b>Caution</b>	<ol style="list-style-type: none"> <li>Check whether the device's package is in good condition, whether there is damage, deformation, etc. before unpacking.</li> <li>After unpacking, please carefully inspect the quantity and appearance of the product and accessories for any abnormalities.</li> <li>Please store and transport the product according to the specified storage and transportation conditions, ensure that the storage temperature and humidity meet the requirements.</li> </ol>

Personal Safety	
 <b>Warning</b>	<ol style="list-style-type: none"> <li>1) It is strictly prohibited to perform device wiring, dismantling, maintenance and other operations while powered on, otherwise there may be a risk of electric shock.</li> <li>2) It is prohibited to touch the camera directly during using, otherwise there may be a risk of burns.</li> <li>3) Please install and use the camera in accordance with regulations, otherwise there may be a risk of falling and get injured.</li> <li>4) The edges of the lens mount and fan are relatively sharp, so pay attention to the risk of scratches during installation or use.</li> </ol>

### 2.3. Guidelines for Avoiding EMI and ESD

You should consider the EMI (Electro Magnetic Interference) and ESD (Electro-Static discharge) problem in the process of using the camera, to guarantee the camera to work in a relatively good electromagnetic environment. The main measures are as follows:

- 1) CAT-5e cables or above with S/STP shielding are recommended.
- 2) Using shielded cable can avoid electro-magnetic interface. Shielding layer of the cable should conduct to ground nearby and not until stretched too long. When many devices need conduct to ground, using single point grounding to avoid earth loop.
- 3) Try to use camera cables that are the correct length. Avoid coiling camera cables. If the cables are too long, use a meandering path rather than coiling the cables.
- 4) Keep your cameras away from equipment with high voltage, or high current (as motor, inverter, relay, etc.). If necessary, use additional shielding.
- 5) ESD (electro-static discharge) may damage cameras permanently, so use suitable clothing (cotton) and shoes, and touch the metal to discharge the electro-static before operating cameras.

### 2.4. Environmental Requirements

- 1) Housing temperature during operation: 0°C ~ 45°C, humidity during operation: 10% ~ 80%.  
Storage temperature: -20°C ~ 70°C.
- 2) To avoid collecting dust in the optical filter, always keep the plastic cap on cameras when no lens is mounted.
- 3) PC requirement: Intel Core 2 Duo, 2.4GHz or above, and 2GB memory or above.
- 4) NIC requirement: Intel Pro 1000 NIC or higher performance Gigabit LAN confirming to IEEE802.3af standard, CAT-5e or CAT-6 cables, less than 100m, Gigabit Switch confirming to IEEE802.3af standard.
- 5) Make sure that cameras are transported in the original factory packages.

## 2.5. Camera Mechanical Installation Precautions

### 1. Camera installation requirements

- 1) The screw and camera have a screw length between 2.5 and 2.7 mm.
- 2) Screw assembly torque  $\leq 1\text{N}\cdot\text{m}$ . If the screw assembly torque is too large, it may cause the camera thread stripping.

### 2. DAHENG tripod adapter instructions

- 1) M3 \* 6 cross recessed cheese head screws are required.
- 2) After the screws pass through the tripod adapter, they are directly assembled with the camera threads.
- 3) DAHENG tripod adapter does not need to use spring washer.

## 2.6. Certification and Declaration

### 1. RoHS

We declare that DAHENG IMAGING VENUS2 GigE cameras have passed the following EU certifications:

- 2011/65/EU—Restriction of Hazardous Substances (RoHS) and its revised directive 2015/863/EU

## 3. Installation

### 3.1. Host Preparation

#### 3.1.1. Software Package

The software package of DAHENG IMAGING's VENUS2 GigE camera is used to control the VENUS2 GigE camera to provide stable, real-time image transmission, and provides a free SDK and abundant development sample source code. The package is composed of the following modules:

- 1) Driver Package (Driver): This package provides the VENUS2 camera driver program, such as: the GigE Vision cameras' Filter Driver Program.
- 2) Interface Library (API): This package provides the camera control interface library and the image processing interface library, supports the user for secondary development.
- 3) Demonstration Program (GalaxyView.exe): This demonstration program is used to display the camera control, image acquisition and image processing functions, the user can control the camera directly by the demonstration program, and the user can develop their own control program based on the camera interface library.
- 4) IP configurator (GxGigEIPConfig.exe): The tool is used to configure the camera IP address and to set the IP mode when the camera is powered on.
- 5) Sample: These samples demonstrate cameras' functions, the user can easily use these samples to control cameras, or refer to the samples to develop their own control programs.
- 6) Programmer's Manual: This manual is the users programming guide that instructs the users how to configure the programming environment and how to control cameras and acquisition images through the camera interface library.

You can download the latest software package from the website: [www.daheng-imaging.com/en/Downloads](http://www.daheng-imaging.com/en/Downloads).

#### 3.1.2. User Software Interface

After installing the VENUS2 GigE camera software package, the user can use the demonstration program and the samples to control the camera, also the user can control the camera by the program which is written by the user themselves. The software package provides three kinds of program interface, the user can select the suitable one for use according to their own requirements:

- 1) API Interface

In order to simplify the users' programming complexity, the package provides the general C programming interface GxIAPI.dll and image processing algorithm interface DxImageProc.dll for the user to control the camera, and provides the samples and software development manual which are based on these interfaces. The API interface supports C/C++/C#/Python, etc.

2) GenTL Interface

This interface is developed according to the standard of general transport layer in Gen<i>Cam standard, DAHENG IMAGING follows the Gen<i>Cam standard and provides the GenTL interface for the user, the user can use the GenTL interface directly to develop their own control program.

In addition, users can use some third-party software that supports Gen<i>Cam standard to control the camera, such as HALCON.

3) GigE Vision interface

The VENUS2 GigE Vision camera is compatible with the GigE Vision protocol, which allows the user to control the camera directly through the PC software based on the GigE Vision protocol.

In addition, the user can use some third-party software that supports the GigE Vision protocol to control the camera, such as HALCON.

● Note

GEN<i>CAM standard: GEN<i>CAM is administered by the European Machine Vision Association (EMVA). GenICam provides a generic programming interface for all kinds of cameras and devices. It provides a standard application programming interface (API), no matter what interface technology is being used. It mainly includes the following modules:

- GenAPI: an XML description file format defining how to capture the features of a device and how to access and control these features in a standard way
- GenTL: a generic Transport Layer Interface, between software drivers and libraries, that transports the image data from the camera to the application running on a PC
- SFNC: common naming convention for camera features, which promotes interoperability between products from different manufacturers

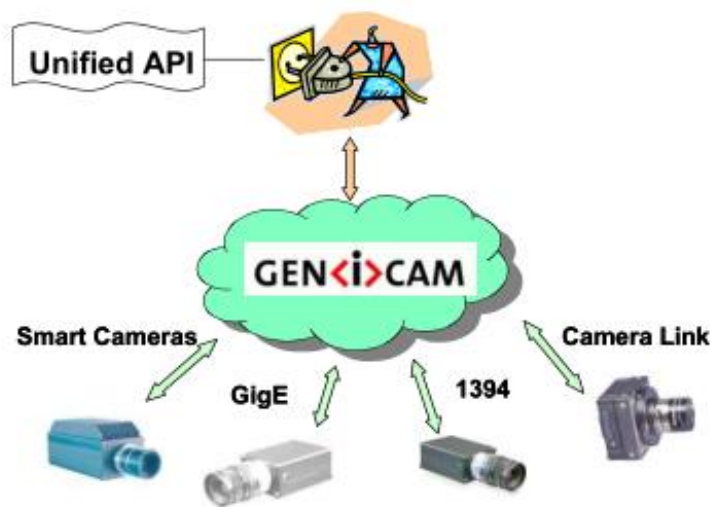

Figure 3-1 GEN<i>CAM standard schematic diagram

## 3.2. Camera Power

The VE2S-G-P series camera can get power in either of two different ways: via PoE (Power over Ethernet) or via Hirose I/O port.

### 1) Via PoE (Power over Ethernet)

Via PoE (Power over Ethernet), i.e., via the Ethernet cable plugged into the camera's RJ45 jack. Use the IEEE 802.3af compliant PSE (Power sourcing equipment) to power the camera.

### 2) Via the Hirose I/O port

The camera can get power from the 8-pin/6-pin Hirose I/O port via a standard I/O cable.

Nominal operating voltage is +12V (± 10%) ~ +24VDC (± 10%).

When you supply power to the camera both via the camera's RJ45 jack and via the Hirose I/O port, the camera will get power via the Hirose I/O port. And if you cut off the Hirose I/O port, the camera will get power via PoE and may restart.

### 1) Voltage outside of the specified range can cause damage.



### 2) The plug on the cable that you attach to the Hirose 8-pin/6-pin receptacle must have 8/6 female pins. Using a plug designed for a smaller or a larger number of pins can damage the connector. See the section 7.3 for the definition of I/O port.

## 3.3. Camera Driver Installation

### 3.3.1. System Requirements

GalaxySDK is suitable for all cameras in the VENUS2. The GalaxySDK contains various operating systems such as Windows, Linux, Android and Mac. The requirements for the operating system and version of the installation package are as follows:

Operating Systems	Applicable Version
Windows	<ul style="list-style-type: none"> <li>➤ Windows 7 (32bit, 64bit)</li> <li>➤ Windows 10 (32bit, 64bit)</li> <li>➤ Windows 11 (64bit)</li> </ul>
Linux	<ul style="list-style-type: none"> <li>➤ Ubuntu 12.04 or above, kernel version 3.5.0.23 or above</li> </ul>
Android	<ul style="list-style-type: none"> <li>➤ Android 6 or above</li> </ul>
Mac OS	<ul style="list-style-type: none"> <li>➤ Mac OS 10.12 or above</li> </ul>

### 3.3.2. Driver Installation

The steps to install the GalaxySDK under Windows are as follows:

- 1) Download the corresponding version of the installation package from [www.daheng-imaging.com/en/Downloads](http://www.daheng-imaging.com/en/Downloads).
- 2) Run the installer.
- 3) Follow the instructions of the installation wizard to complete the installation process. During the installation process, you can choose the camera interface you need (USB2.0, USB3 Vision, GigE Vision, etc.).

During the installation process, especially when installing the \*.sys file, you must always pay attention to the anti-virus software to intercept the driver. If intercepted, it may cause the driver installation to fail.

### 3.4. Camera IP Configuration

The IP Configurator provided by GalaxySDK eliminates the need for users to configure IP for hosts and devices. Implement one-click configuration IP. You only need to follow the steps below to configure the camera IP. For details on how to use the tool, please refer to section 9.1.

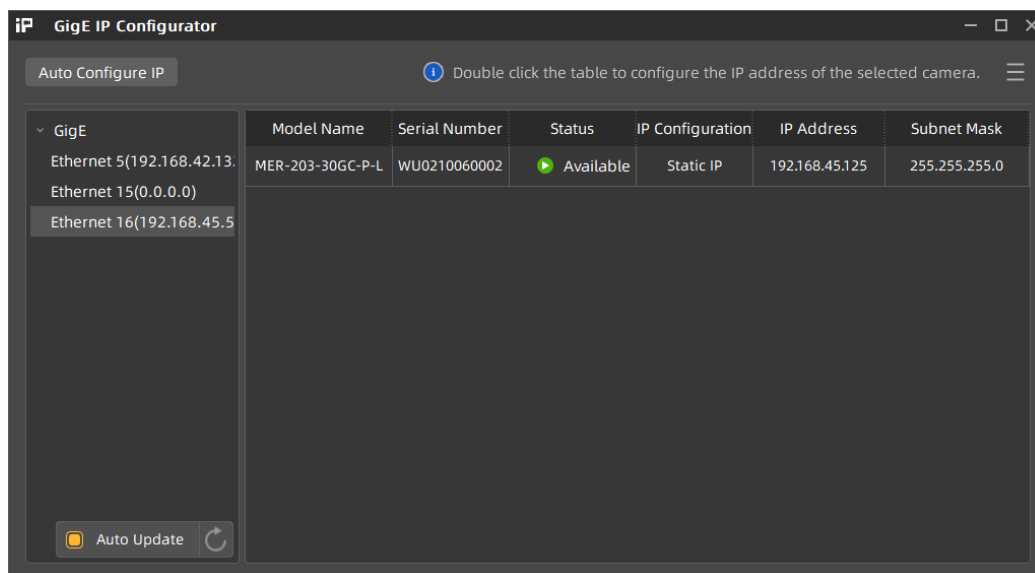



Figure 3-2 GigE IP Configurator

### 3.5. Open Device and Start Acquisition

After powering the device, connecting the device to the host, and configuring the IP, you can double-click the GalaxyView software to acquire image. The steps are as follows:

- 1) Click the  icon on the Device Tree in the GalaxyView to refresh device list.
- 2) After the device is enumerated, double-click the device enumerated in the device list.
- 3) Click the  icon on the Device Tree to perform the Start Acquisition operation on the current device.

## 3.6. Hardware System and Installation

During installation and debugging, human bodies may discharge components on the PCB board and causing permanent damage to the camera. So, before touching the camera, wear an anti-static bracelet or touch the metal frame to release the accumulated electric charge from the human body.

There is a limit to the number of times that connectors (gold finger or board to board) can be inserted and opened (typically 20 times), and electrical performance may be reduced after exceeding this limit. Please avoid repeated plugging and unplugging operations during use.

### 3.6.1. All-in-one Vertical FPC Camera's Hardware Composition

The camera consists of three parts: camera body, FPC cable (20cm, customizable), and an optional Ethernet interface module.

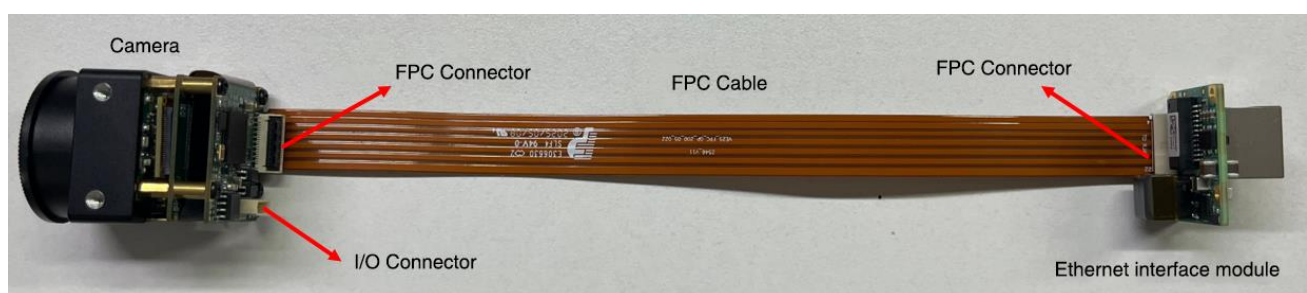

Figure 3-3 All-in-one vertical FPC camera's hardware composition

Step1: Connect the FPC cable to the camera according to the following picture's red box part: the FPC cable's connecting finger facing up, insert it into the white FPC card holder and rotate the black locking mechanism 90 degrees downward to lock the FPC cable.

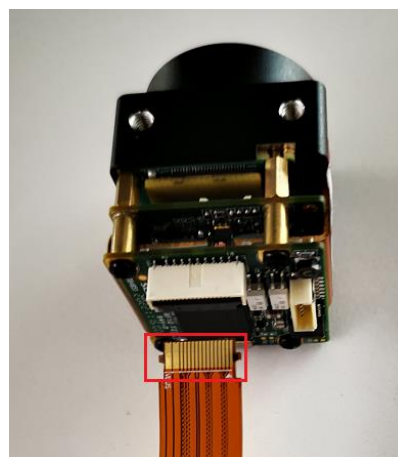

Figure 3-4 FPC cable connect to the camera

Step2: PFC cable connecting to the RJ45 adapter board according to the following picture's red box part: the FPC cable's connecting finger facing up, insert it into the white FPC card holder and rotate the black locking mechanism 90 degrees downward to lock the FPC cable.

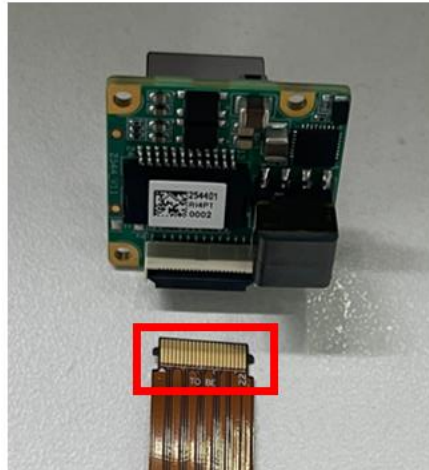

Figure 3-5 FPC cable connect to the RJ45 adapter board

### 3.6.2. Split Vertical FPC Camera's Hardware Composition

The split camera, based on an all-in-one camera design, physically separates the imaging board using the FPC cable. This configuration is ideal for scenarios with limited installation space or requiring specialized optical paths.

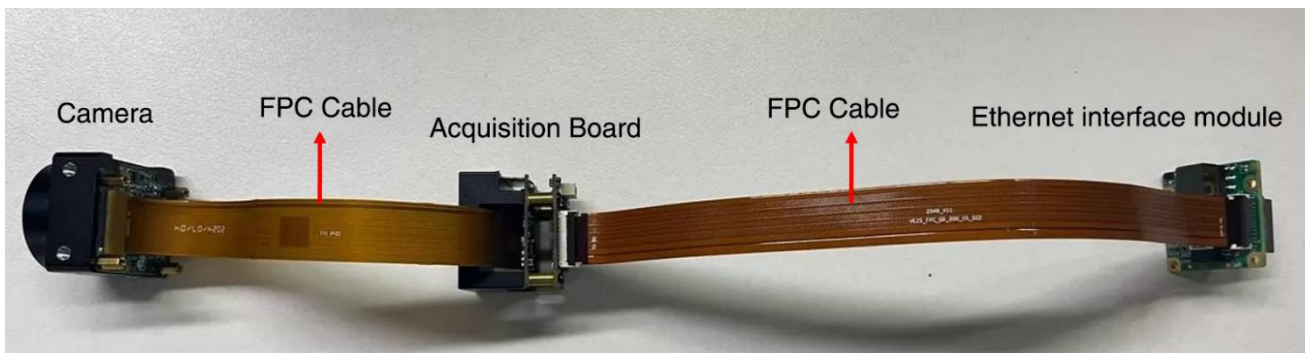

Figure 3-6 Split vertical FPC camera's hardware composition

Step1: FPC cable connect to the image board, according to the following figure: the side marked with " TO SENSOR " connect to the image board.

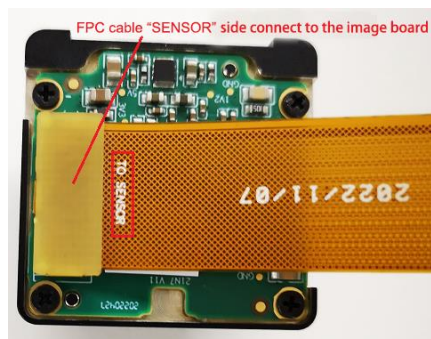

Figure 3-7 FPC cable connect to the image board

Step2: FPC cable with “TO BE” connect to the acquisition board.

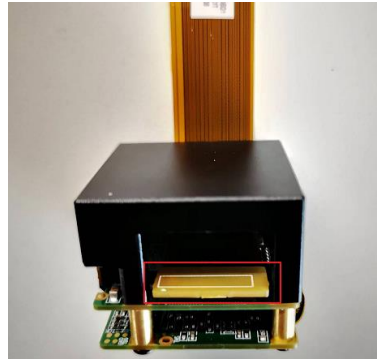

Figure 3-8 FPC cable connect to the acquisition board

Step3: Connect the FPC cable to the camera according to the following picture's red box part: the FPC cable's connecting finger facing up, insert it into the white FPC card holder and rotate the black locking mechanism 90 degrees downward to lock the FPC cable.

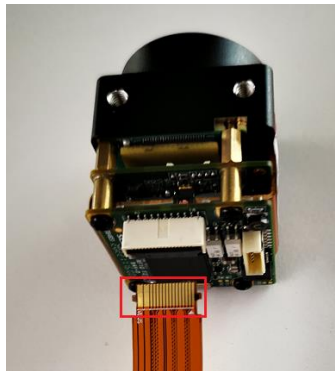

Figure 3-9 FPC cable connect to the FPC holder

Step4: PFC cable connecting to the RJ45 adapter board according to the following picture's red box part: the FPC cable's connecting finger facing up, insert it into the white FPC card holder and rotate the black locking mechanism 90 degrees downward to lock the FPC cable.

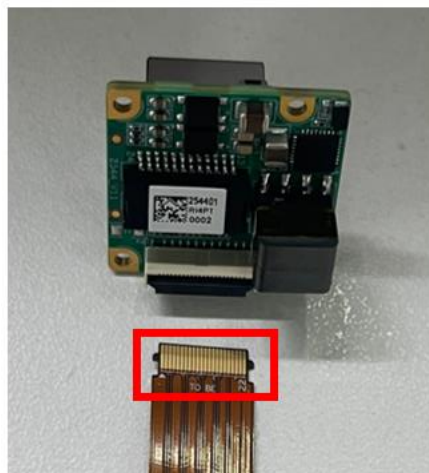

Figure 3-10 FPC cable connect to the RJ45 adapter board

## 4. General Specifications

### 4.1. Explanation of Important Parameters

#### 4.1.1. About Spectral Response

QE: Which is the ratio of the average number of photoelectrons produced per unit time to the number of incident photons at a given wavelength.

Sensitivity: The change of the sensor output signal relative to the incident light energy. The commonly used sensitivity units are  $V/((W/m^2) \cdot s)$ ,  $V/lux \cdot s$ ,  $e-/((W/m^2) \cdot s)$  or  $DN/ ((W/m^2) \cdot s)$ .

The spectral response graphs given by different manufacturers are different. Some graphs' ordinate is relative sensitivity response, and abscissa is wavelength. Some graphs' ordinate is QE, and abscissa is wavelength.

### 4.2. VE2S-G-P Series

#### 4.2.1. VE2S-042-121GM/C-P

Specifications	VE2S-042-121GC-P	VE2S-042-121GM-P
Resolution	720 × 540	
Sensor	Sony IMX297 global shutter CMOS	
Max. Image Circle	1/2.9 inch	
Pixel Size	6.9 $\mu$ m × 6.9 $\mu$ m	
Frame Rate	121.8fps @ 720 × 540	
ADC Bit Depth	10bit	
Pixel Bit Depth	8bit, 10bit	
Mono/Color	Color	Mono
Pixel Formats	Bayer RG8/Bayer RG10	Mono8/Mono10
Signal Noise Ratio	43.13dB	43.18dB
Exposure Time	UltraShort: 1 $\mu$ s~100 $\mu$ s, Actual Steps: 1 $\mu$ s Standard: 20 $\mu$ s~1s, Actual Steps: 1 row period	
Gain	0dB~24dB, Default: 0dB, Steps: 0.1dB	
Binning	FPGA: 1×1, 1×2, 1×4, 2×1, 2×2, 2×4, 4×1, 4×2, 4×4	
Decimation	FPGA: 1×1, 1×2, 1×4, 2×1, 2×2, 2×4, 4×1, 4×2, 4×4	

Synchronization	Hardware trigger, software trigger
I/O	1 input and 1 output with opto-isolated, 1 programmable GPIO
Operating Temp.	0°C~45°C
Storage Temp.	-20°C~70°C
Operating Humidity	10%~80%
Power Requirements	PoE (Power over Ethernet, IEEE802.3af compliant) or 12VDC-10% ~ 24VDC+10% supplied via the camera's Hirose connector
Typical Power	2.10W@12VDC, 2.48W@PoE
Lens Mount	C
Data Interface	Fast Ethernet (100Mbit/s) or Gigabit Ethernet (1000Mbit/s)
Dimensions	31mm × 29mm × 30.3mm (without lens adapter)
Weight	47g
Operating System	Windows 7/10/11/Embedded 32bit/64bit, Linux Ubuntu14.04/16.04, etc. Mac OS 10.12/10.13/10.14/10.15, etc. (Only support Gigabit Ethernet Camera)
Programmable Control	Image size, gain, exposure time, trigger polarity, flash polarity
Conformity	RoHS, GigE Vision, GenICam

Table 4-1 VE2S-042-121GM/C-P camera parameter

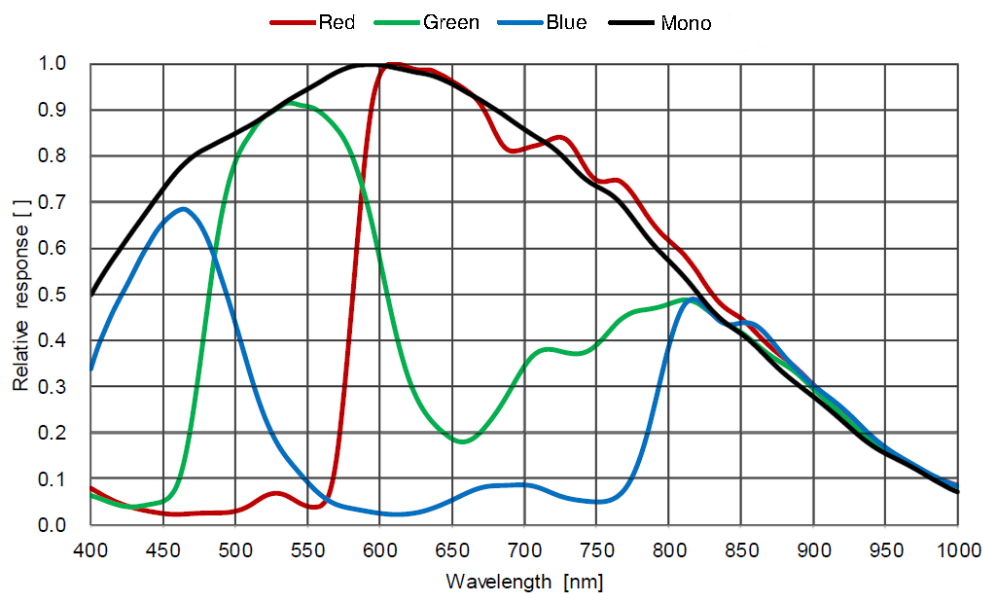

Figure 4-1 VE2S-042-121GM/C-P sensor spectral response

## 4.2.2. VE2S-161-75GM/C-P

Specifications	VE2S-161-75GC-P	VE2S-161-75GM-P
Resolution	1440 × 1080	
Sensor	Sony IMX296 global shutter CMOS	
Max. Image Circle	1/2.9 inch	
Pixel Size	3.45μm × 3.45μm	
Frame Rate	75.6fps @ 1440 × 1080 (adjust the packet size to 8192 and reserved bandwidth to 5)	
ADC Bit Depth	10bit	
Pixel Bit Depth	8bit, 10bit	
Mono/Color	Color	Mono
Pixel Formats	Bayer RG8/Bayer RG10	Mono8/Mono10
Signal Noise Ratio	40.50dB	40.48dB
Exposure Time	UltraShort: 1μs~100μs, Actual Steps: 1μs Standard: 20μs~1s, Actual Steps: 1 row period	
Gain	0dB~24dB, Default: 0dB, Steps: 0.1dB	
Binning	FPGA: 1×1, 1×2, 1×4, 2×1, 2×2, 2×4, 4×1, 4×2, 4×4 Sensor: 1×1, 2×2 (only mono models)	
Decimation	FPGA: 1×1, 1×2, 1×4, 2×1, 2×2, 2×4, 4×1, 4×2, 4×4	
Synchronization	Hardware trigger, software trigger	
I/O	1 input and 1 output with opto-isolated, 1 programmable GPIO	
Operating Temp.	0°C~45°C	
Storage Temp.	-20°C~70°C	
Operating Humidity	10%~80%	
Power Requirements	PoE (Power over Ethernet, IEEE802.3af compliant) or 12VDC-10% ~ 24VDC+10% supplied via the camera's Hirose connector	
Typical Power	2.24W@12VDC; 2.66W@PoE	
Lens Mount	C	
Data Interface	Fast Ethernet (100Mbit/s) or Gigabit Ethernet (1000Mbit/s)	
Dimensions	31mm × 29mm × 30.3mm (without lens adapter)	
Weight	47g	

Operating System	Windows 7/10/11/Embedded 32bit/64bit, Linux Ubuntu14.04/16.04, etc. Mac OS 10.12/10.13/10.14/10.15, etc. (Only support Gigabit Ethernet Camera)
Programmable Control	Image size, gain, exposure time, trigger polarity, flash polarity
Conformity	RoHS, GigE Vision, GenICam

Table 4-2 VE2S-161-75GM/C-P camera parameter

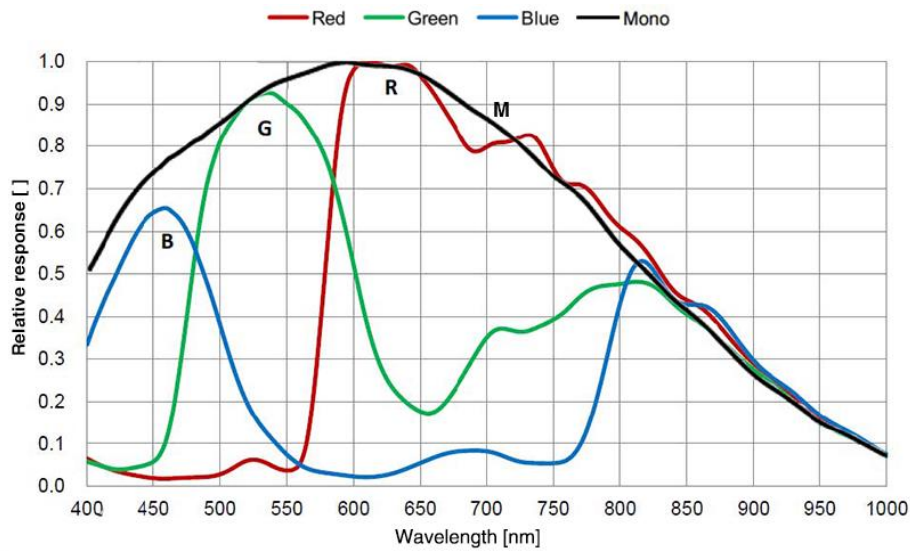

Figure 4-2 VE2S-161-75GM/C-P sensor spectral response

#### 4.2.3. VE2S-303-37GM/C-P

Specifications	VE2S-303-37GC-P	VE2S-303-37GM-P
Resolution	2048 × 1536	
Sensor	Sony global shutter CMOS	
Max. Image Circle	1/1.8 inch	
Pixel Size	3.45μm × 3.45μm	
Frame Rate	37.4fps @ 2048 × 1536 (adjust the packet size to 8192 and reserved bandwidth to 5)	
ADC Bit Depth	12bit	
Pixel Bit Depth	8bit, 12bit	
Mono/Color	Color	Mono
Pixel Formats	Bayer RG8/Bayer RG12	Mono8/Mono12
Signal Noise Ratio	40.84dB	40.86dB
Exposure Time	UltraShort: 1μs~100μs, Actual Steps: 1μs Standard: 20μs~1s, Actual Steps: 1 row period	

Gain	0dB~24dB, Default: 0dB, Steps: 0.1dB	
Binning	-	FPGA: 1×1, 1×2, 2×1, 2×2
Decimation	-	FPGA: 1×1, 1×2, 2×1, 2×2
Synchronization	Hardware trigger, software trigger	
I/O	1 input and 1 output with opto-isolated, 1 programmable GPIO	
Operating Temp.	0°C~45°C	
Storage Temp.	-20°C~70°C	
Operating Humidity	10%~80%	
Power Requirements	PoE (Power over Ethernet, IEEE802.3af compliant) or 12VDC-10% ~ 24VDC+10% supplied via the camera's Hirose connector	
Typical Power	2.53W@12VDC, 2.93W@PoE	
Lens Mount	C	
Data Interface	Fast Ethernet (100Mbit/s) or Gigabit Ethernet (1000Mbit/s)	
Dimensions	31mm × 29mm × 30.9mm (without lens adapter)	
Weight	49g	
Operating System	Windows 7/10/11/Embedded 32bit/64bit, Linux Ubuntu14.04/16.04, etc. Mac OS 10.12/10.13/10.14/10.15, etc. (Only support Gigabit Ethernet Camera)	
Programmable Control	Image size, gain, exposure time, trigger polarity, flash polarity	
Conformity	RoHS, GigE Vision, GenICam	

Table 4-3 VE2S-303-37GM/C-P camera parameter

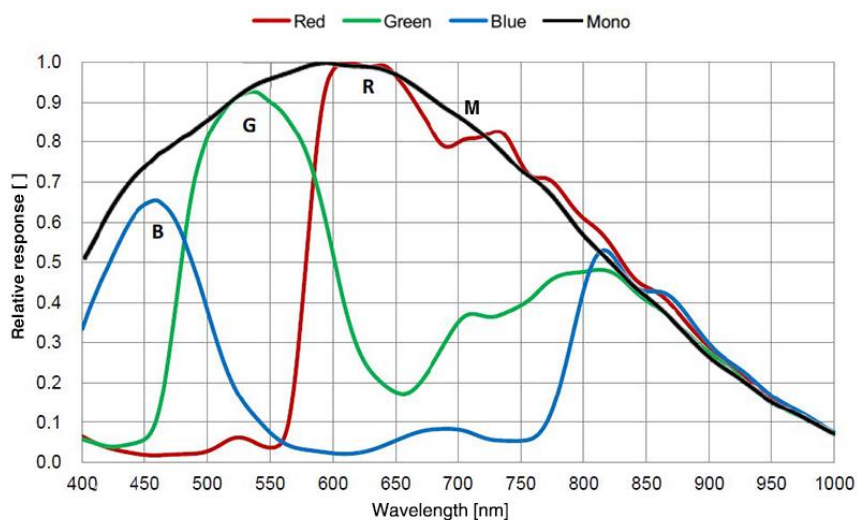

Figure 4-3 VE2S-303-37GM/C-P sensor spectral response

## 4.2.4. VE2S-501-23GM/C-P

Specifications	VE2S-501-23GC-P	VE2S-501-23GM-P
Resolution	2448 × 2048	
Sensor	Sony global shutter CMOS	
Max. Image Circle	2/3 inch	
Pixel Size	3.45μm × 3.45μm	
Frame Rate	22.23fps @ 2448 × 2048	
ADC Bit Depth	12bit	
Pixel Bit Depth	8bit, 12bit	
Mono/Color	Color	Mono
Pixel Formats	Bayer RG8/Bayer RG12	Mono8/Mono12
Signal Noise Ratio	40.55dB	40.32dB
Exposure Time	UltraShort: 1μs~100μs, Actual Steps: 1μs Standard: 20μs~1s, Actual Steps: 1 row period	
Gain	0dB~24dB, Default: 0dB, Steps: 0.1dB	
Binning	-	FPGA: 1×1, 1×2, 2×1, 2×2
Decimation	Sensor: 1×1, 2×2	Sensor: 1×1, 2×2
Synchronization	Hardware trigger, software trigger	
I/O	1 input and 1 output with opto-isolated, 1 programmable GPIO	
Operating Temp.	0°C~45°C	
Storage Temp.	-20°C~70°C	
Operating Humidity	10%~80%	
Power Requirements	PoE (Power over Ethernet, IEEE802.3af compliant) or 12VDC-10% ~ 24VDC+10% supplied via the camera's Hirose connector	
Typical Power	2.53W@12VDC, 2.93W@PoE	
Lens Mount	C	
Data Interface	Fast Ethernet (100Mbit/s) or Gigabit Ethernet (1000Mbit/s)	
Dimensions	31mm × 29mm × 30.9mm (without lens adapter)	
Weight	49g	
Operating System	Windows 7/10/11/Embedded 32bit/64bit, Linux Ubuntu14.04/16.04, etc. Mac OS 10.12/10.13/10.14/10.15, etc. (Only support Gigabit Ethernet Camera)	

Programmable Control	Image size, gain, exposure time, trigger polarity, flash polarity
Conformity	RoHS, GigE Vision, GenICam

Table 4-4 VE2S-501-23GM/C-P camera parameter

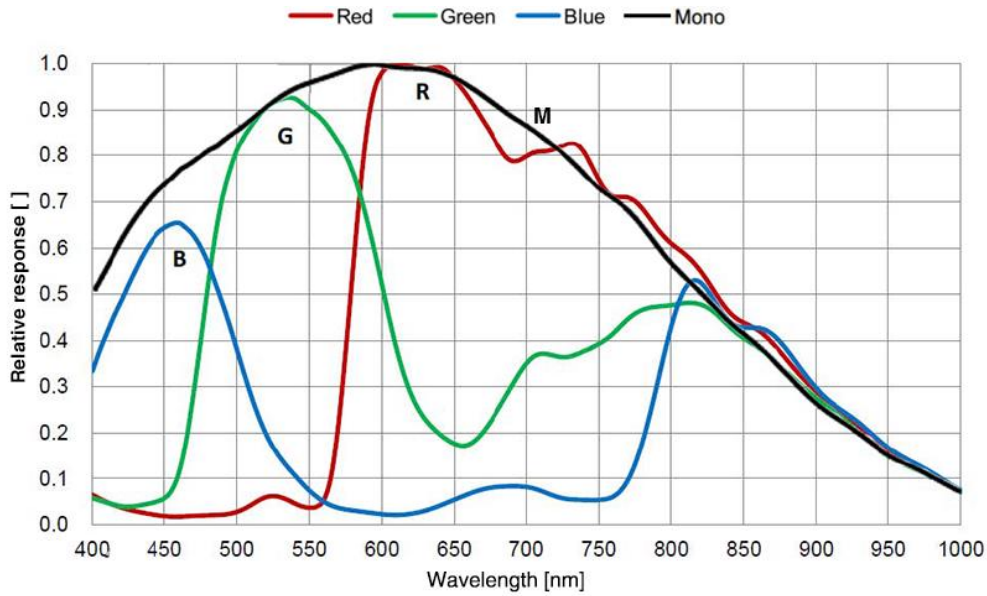

Figure 4-4 VE2S-501-23GM/C-P sensor spectral response

4.2.5. VE2S-630-18GM/C-P

Specifications	VE2S-630-18GC-P	VE2S-630-18GM-P
Resolution	3088 × 2064	
Sensor	Sony IMX178 rolling shutter CMOS	
Max. Image Circle	1/1.8 inch	
Pixel Size	2.4μm × 2.4μm	
Frame Rate	18.45fps @ 3088 × 2064 (adjust the packet size to 8192 and reserved bandwidth to 5)	
ADC Bit Depth	12bit	
Pixel Bit Depth	8bit, 12bit	
Mono/Color	Color	Mono
Pixel Formats	Bayer RG8/Bayer RG12/Mono8/RGB8/BGR8/YUV422_8/YUV422_8_UYVY	Mono8/Mono12
Signal Noise Ratio	39.67dB	40.14dB
Exposure Time	Standard: 19μs~1s, GRR: 38μs~0.2s, Actual Steps: 1 row period	
Gain	0dB~24dB, Default: 0dB, Steps: 0.1dB	
Binning	1×1, 1×2, 2×1, 2×2	-

Decimation	FPGA: 1×1, 1×2, 2×1, 2×2	-
Synchronization	Hardware trigger, software trigger	
I/O	1 input and 1 output with opto-isolated, 1 programmable GPIO	
Operating Temp.	0°C~45°C	
Storage Temp.	-20°C~70°C	
Operating Humidity	10%~80%	
Power Requirements	PoE (Power over Ethernet, IEEE802.3af compliant) or 12VDC-10% ~ 24VDC+10% supplied via the camera's Hirose connector	
Typical Power	1.92W@12VDC, 2.12W@PoE	
Lens Mount	C	
Data Interface	Fast Ethernet (100Mbit/s) or Gigabit Ethernet (1000Mbit/s)	
Dimensions	31mm × 29mm × 30.9mm (without lens adapter)	
Weight	49g	
Operating System	Windows 7/10/11/Embedded 32bit/64bit, Linux Ubuntu14.04/16.04, etc. Mac OS 10.12/10.13/10.14/10.15, etc. (Only support Gigabit Ethernet Camera)	
Programmable Control	Image size, gain, exposure time, trigger polarity, flash polarity	
Conformity	RoHS, GigE Vision, GenICam	

Table 4-5 VE2S-630-18GM/C-P camera parameter

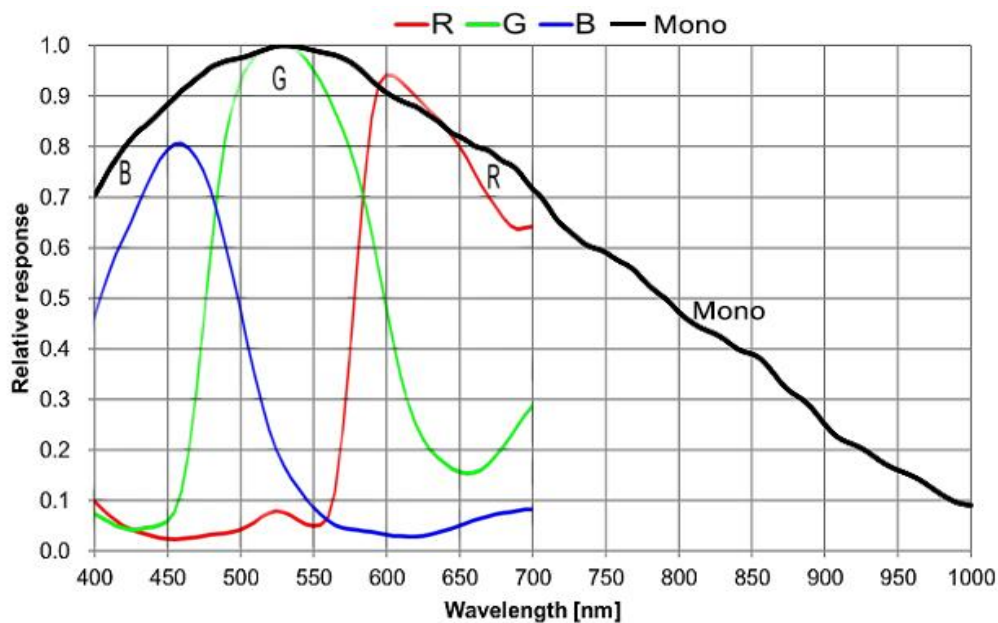

Figure 4-5 VE2S-630-18GM/C-P sensor spectral response

## 5. Dimensions

### 5.1. Camera Dimensions

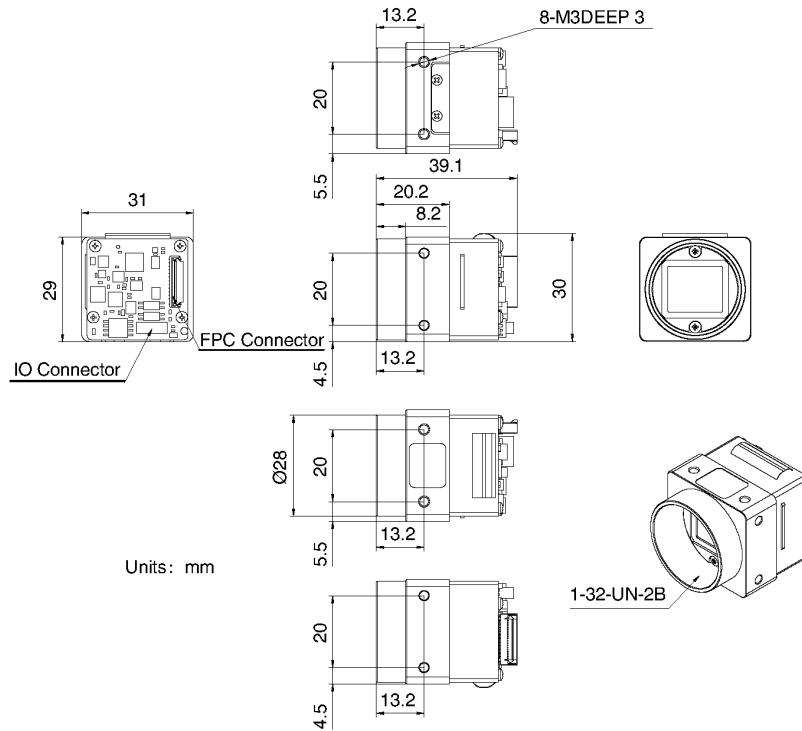

Figure 5-1 VE2S-G-P mechanical dimensions

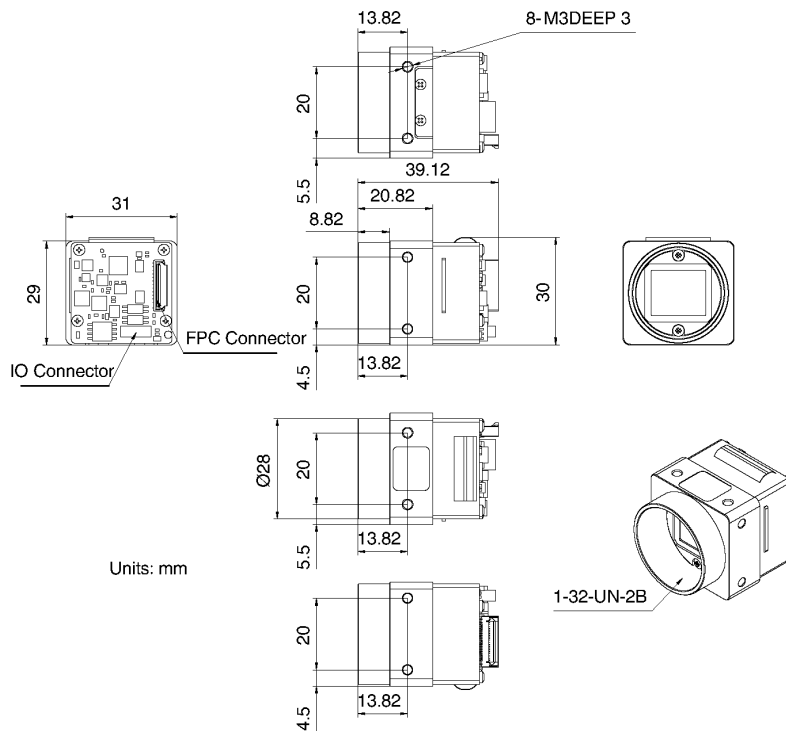

Figure 5-2 VE2S-G-P mechanical dimensions (VE2S-042, VE2S-161)

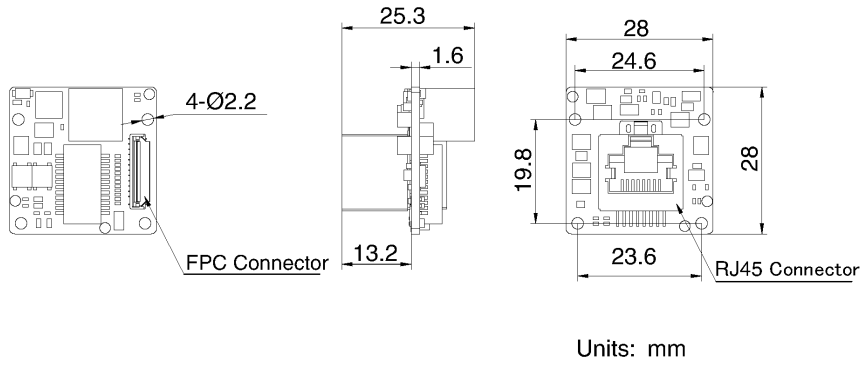

Figure 5-3 VE2S-G-P RJ45 board mechanical dimensions

## 5.2. Optical Interface

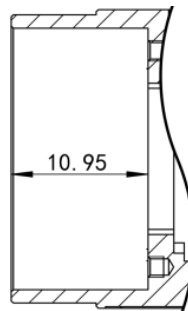

Figure 5-4 Optical interface of C-mount

Cameras are equipped with C-mount lens adapters. The back-flange distance is 17.526 mm (in the air). The maximum allowed thread length of lens should be less than 10.95 mm, as shown in Figure 5-4. A longer lens thread will damage camera.

The color models are equipped with an IR filter and the cut-off frequency is 700 nm. The mono models are equipped with transparent glasses. Remove IR-filters or transparent glasses will defocus the image plane.

Contact our technical support when the glass needed to be removed.

## 5.3. Tripod Adapter Dimensions

When customizing the tripod adapter, you need to consider the relationship between tripod adapter, screw length and step thickness of tripod adapter.

- 1) Screw length = tripod adapter step thickness + spring washer thickness + Screwing length of camera screw thread

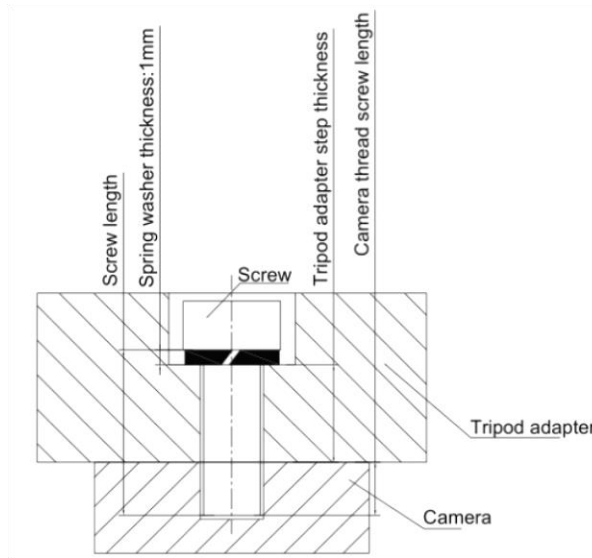

Figure 5-5 Schematic diagram of screw specification, tripod adapter step thickness and spring washer thickness

2) It is recommended that you select the screw specifications and the tripod adapter step thickness from the table below:

Screw specification	Tripod adapter step thickness (mm)	Spring washer thickness (mm)	Screwing length of camera screw thread (mm)
M3*6 screw	2.5	0.8	2.7
M3*8 screw	4.5	0.8	2.7
M3*10 screw	6.5	0.8	2.7



If the screw specification and the thickness of the tripod adapter do not conform to the requirement above, it may cause the camera thread hole through or thread stripping.

## 6. Filters and Lenses

### 6.1. Filters

The VENUS2 color models are equipped with IR filters. The thickness of the filter is  $0.7\pm 0.05$  mm, and the cut-off frequency is 700 nm, which reduces the influence of invisible light on the image. The monochrome models are equipped with transparent glasses. Remove IR-filters or transparent glasses will defocus the image plane.

Contact our technical support when the glass needed to be removed.

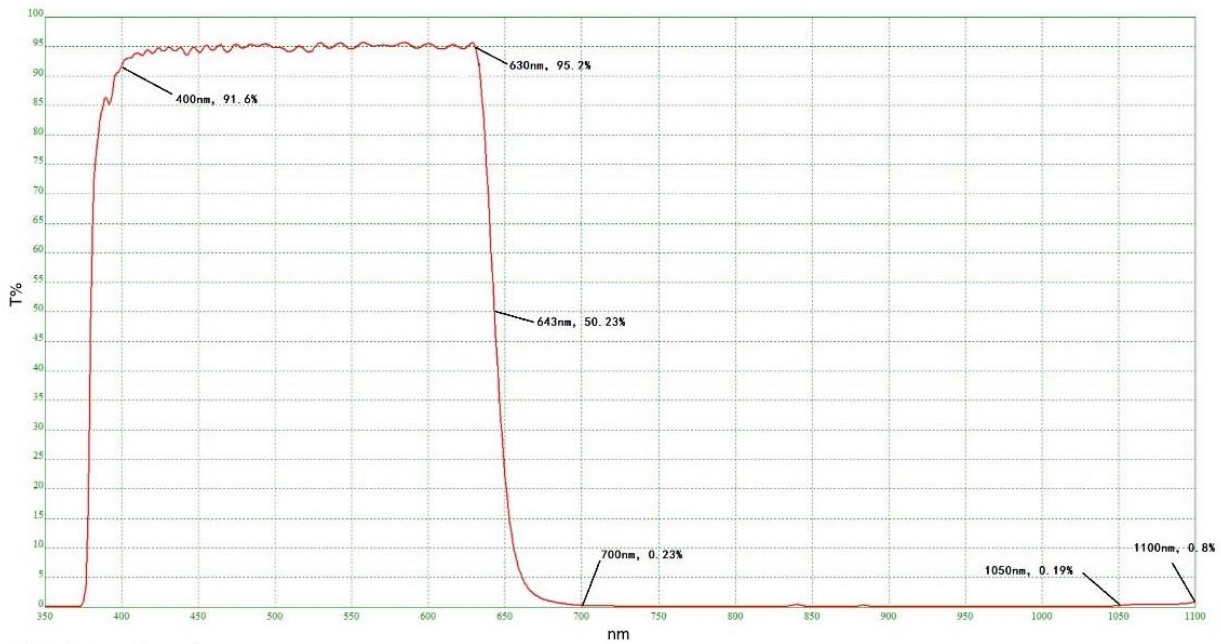

Technical requirements:

1. 0 degree incidence: Tavg > 90% @ 400-630nm
2. T = 50% @ 645±5nm
3. Tavg < 1% @ 700-1050nm
4. Tavg < 2% @ 1050-1100nm

Figure 6-1 Infrared cut-off filter transmittance curve for color camera

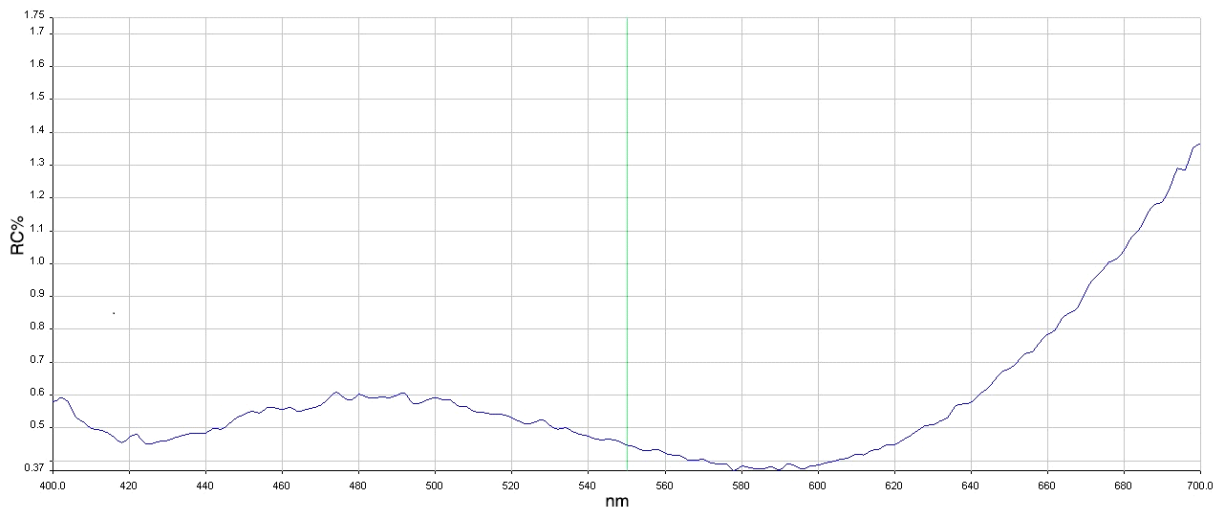

Figure 6-2 Transparent glass reflectance curve for mono camera

## 6.2. Lens Selection Reference

DAHENG IMAGING is a professional supplier for images and machine vision devices in China. In addition to industry cameras, it also provides high-resolution, high-optical machine vision lenses for a wide range of industry cameras on the market.

In order to meet the requirements of machine vision for high resolution and low distortion, DAHENG IMAGING released eight series of industrial lenses, resolution from 2 megapixels to 25 megapixels, with small size, light weight, high resolution and low distortion rate, etc.

When choosing a lens, there are several factors to consider:

### 1) Lens mount

- According to the connection methods of the lens and the camera, the commonly used mounts are C, CS, F, V, Leica, M42, M58, M72, M90, and so on
- The VENUS2 GigE camera is equipped with a standard C-Mount. When selecting a lens, select the lens of the same mount as the camera

### 2) Max. Image Circle

- The maximum sensor size that the lens image can cover. There are mainly 1/2", 2/3", 1/1.2", 1", 1.1", 4/3", and so on
- When selecting a lens, make sure that the max. image circle of the lens is not smaller than the sensor size of the camera

### 3) Resolution

- The resolution represents the ability of the lens to record the details of the object, usually in units of line pairs that can be resolved per millimeter: line pair/mm (lp/mm). The higher the resolution of the lens, the sharper the image
- When selecting a lens, make sure that the accuracy required by the system is less than the resolution of the lens

### 4) Working distance

- The distance from the first working surface of the lens to the object being measured
- When selecting a lens, make sure that the working distance is larger than the lens parameter "minimum object distance"

### 5) Focal length

- The focal length is the distance from the center point of the lens to the clear image formed on the focal plane. The smaller the focal length value, the larger the field of view of the camera
- For focal length calculation, we need to confirm three parameters: the field of view, the sensor size of the camera and the working distance. The focal length (f) of the expected lens can be calculated by the following formula

$f = \text{sensor size (horizontal or vertical)} * \text{Working distance} / \text{Field of View (corresponding to the horizontal or vertical direction of the sensor size)}$

The corresponding lens is selected by the calculated focal length.

### 6.2.1. HN-2M Series Prime Lenses

The HN-2M series lenses are 2 megapixels lenses for industrial, suitable for sensors with max. image circle of 1/2" ~ 2/3". This series of lenses has the following features:

- High optical performance with optical design supporting up to 2/3" sensor size, 6.2μm pixel size (up to 2 megapixels) sensor. 8 models with F values below 2.8, clear images can be obtained even in low light environment
- Excellent anti-shock and anti-vibration performance, with a unique mechanical structure, the optical axis fluctuates below 10μm
- The housing is small and compact, the minimum outer diameter is only φ29.5mm, and it can be installed in various limited spaces
- Easy to install, there are 3 fixing holes on the lens barrel for fixing the iris and focusing. The best fixing hole can be selected according to the installation environment

Models:

- |                    |                    |                      |
|--------------------|--------------------|----------------------|
| ● HN-0612-2M-C1/2X | ● HN-0914-2M-C2/3X | ● HN-12.514-2M-C2/3X |
| ● HN-1614-2M-C2/3X | ● HN-2514-2M-C2/3X | ● HN-3516-2M-C2/3X   |
| ● HN-5023-2M-C2/3X | ● HN-7528-2M-C2/3X |                      |

### 6.2.2. HN-5M Series Prime Lenses

The HN-5M series lenses are 5 megapixels lenses for industrial, suitable for sensors with max. image circle of 2/3" ~ 1.1". This series of lenses has the following features:

- 5 megapixels resolution, the definition is consistent from the center to the periphery, greatly improving the distance between iris and photography
- The housing is small and compact, the minimum outer diameter is only φ29.5mm, and it can be installed in various limited spaces
- Easy to install, there are 3 fixing holes on the lens barrel for fixing the iris and focusing. The best fixing hole can be selected according to the installation environment

Models:

- |                    |                    |                    |
|--------------------|--------------------|--------------------|
| ● HN-0619-5M-C2/3X | ● HN-0816-5M-C2/3X | ● HN-1216-5M-C2/3X |
| ● HN-1616-5M-C2/3X | ● HN-2516-5M-C2/3X | ● HN-3519-5M-C2/3X |
| ● HN-5024-5M-C2/3X |                    |                    |

### 6.2.3. HN-6M Series Prime Lenses

The HN-6M series lenses are 6 megapixels lenses for industrial, suitable for sensors with max. image circle of 2/3". This series of lenses has the following features:

- 6 megapixels resolution, 5~75mm focal length available
- Stable performance at long working distance

- Compact and robust
- Up to 5G of anti-vibration performance

Models:

- |                    |                    |                    |
|--------------------|--------------------|--------------------|
| ● HN-0528-6M-C2/3B | ● HN-0828-6M-C2/3B | ● HN-1228-6M-C2/3B |
| ● HN-1628-6M-C2/3B | ● HN-2528-6M-C2/3B | ● HN-3528-6M-C2/3B |
| ● HN-5028-6M-C2/3B | ● HN-7528-6M-C2/3B |                    |

#### 6.2.4. HN-20M Series Prime Lenses

The HN-20M series lenses are 20 megapixels lenses for industrial, suitable for sensors with max. image circle of 1". This series of lenses has the following features:

- 20 megapixels resolution, 8~75mm focal length available
- Ultra-low optical distortion and excellent uniformity of brightness
- Stable performance at different working distance by floating design
- The housing is small and compact, up to 5G of anti-vibration performance
- The definition is consistent from the center to the periphery, greatly improving the distance between iris and photography

Models:

- |                     |                     |                     |
|---------------------|---------------------|---------------------|
| ● HN-0826-20M-C1/1X | ● HN-1226-20M-C1/1X | ● HN-1624-20M-C1/1X |
| ● HN-2520-20M-C1/1X | ● HN-3522-20M-C1/1X | ● HN-5024-20M-C1/1X |
| ● HN-7531-20M-C1/1X |                     |                     |

#### 6.2.5. HN-P-6M Series Prime Lenses

The HN-P-6M series lenses are 6 megapixels lenses for industrial, suitable for sensors with max. image circle of 1/1.8" ~ 2/3". This series of lenses has the following features:

- 6 megapixels resolution, 6~50mm focal length available
- The housing is small and compact, the minimum outer diameter is only  $\varphi 33.0\text{mm}$ , and it can be installed in various limited spaces
- Ultra-low optical distortion, greatly improving the accuracy and stability

Models:

- |                       |                       |                       |
|-----------------------|-----------------------|-----------------------|
| ● HN-P-0628-6M-C1/1.8 | ● HN-P-0828-6M-C1/1.8 | ● HN-P-1228-6M-C1/1.8 |
| ● HN-P-1628-6M-C1/1.8 | ● HN-P-2528-6M-C1/1.8 | ● HN-P-3528-6M-C1/1.8 |
| ● HN-P-5028-6M-C1/1.8 | ● HN-P-0828-6M-C2/3   | ● HN-P-1228-6M-C2/3   |
| ● HN-P-1628-6M-C2/3   | ● HN-P-2528-6M-C2/3   | ● HN-P-3528-6M-C2/3   |

### 6.2.6. HN-P-10M Series Prime Lenses

The HN-P-10M series lenses are 10 megapixels lenses for industrial, suitable for sensors with max. image circle of 2/3". This series of lenses has the following features:

- 10 megapixels resolution, 8~50mm focal length available
- 2.4 $\mu$ m small pixel size, F1.8 large aperture design
- The housing is small and compact, the minimum outer diameter is only  $\phi$ 32.0mm, and it can be installed in various limited spaces
- Ultra-low optical distortion

Models:

- HN-P-0824-10M-C2/3
- HN-P-1220-10M-C2/3
- HN-P-1618-10M-C2/3
- HN-P-2518-10M-C2/3
- HN-P-3520-10M-C2/3
- HN-P-5028-10M-C2/3

### 6.2.7. HN-P-20M Series Prime Lenses

The HN-P-20M series lenses are 20 megapixels lenses for industrial, with max. image circle of 1.1". This series of lenses has the following features:

- 20 megapixels resolution, 12~50mm focal length available
- 2.4 $\mu$ m small pixel size, F2.4 large aperture design
- Miniaturized structure
- Ultra-low optical distortion

Models:

- HN-P-1224-20M-C1.1/1
- HN-P-1624-20M-C1.1/1
- HN-P-2524-20M-C1.1/1
- HN-P-3524-20M-C1.1/1
- HN-P-5024-20M-C1.1/1

### 6.2.8. HN-P-25M Series Prime Lenses

The HN-P-25M series lenses are 25 megapixels lenses for industrial, suitable for sensors with max. image circle of 1.2". This series of lenses has the following features:

- 25 megapixels resolution, 12~50mm focal length available
- 2.74 $\mu$ m small pixel size, F2.4 large aperture design
- Small and compact
- Ultra-low optical distortion

Models:

- HN-P-1224-25M-C1.2/1
- HN-P-1624-25M-C1.2/1
- HN-P-2524-25M-C1.2/1
- HN-P-3524-25M-C1.2/1
- HN-P-5024-25M-C1.2/1

## 7. Electrical Interface

### 7.1. LED Light

The camera's BE board and RJ45 board are each equipped with an LED indicator light to display the camera's status, and both lights display identical status information, as shown in Table 7-1. LED light can display 3 colors: red, yellow and green.



Figure 7-1 LED of BE board

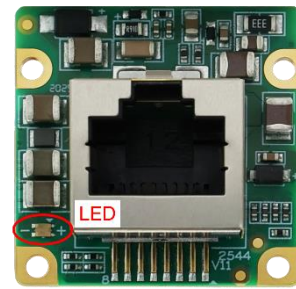

Figure 7-2 LED of RJ45 board

LED status	Camera status
Off	No power
Solid red	The camera is powered on, but the program does not start properly
Solid green	Ethernet is connected, but no data is being transmitted
Solid yellow	The camera starts properly, but the network connection is not established
Flashing yellow	The camera's permanent IP address and other real-time save parameters are incorrect or the camera is started in the userset mode, the parameter set is wrong, and the camera is switched to the default mode to start. Use the IP Configurator to save the camera IP or re-save the userset. After the camera is powered on, the LED status returns to green
Flashing green	Data is being transmitted through Ethernet
Flashing yellow-green	Camera initialization failed

Table 7-1 Camera status

### 7.2. Ethernet Port

The VE2S-G-P camera offers two connection methods when networking with a host device:

- 1) Standard RJ45 Interface: Requires an optional Ethernet module and uses an Ethernet cable for host connection.
- 2) FPC Interface: Eliminates the need for an optional Ethernet module by using an FPC cable for direct connection to the host, facilitating secondary development and embedded applications.

Users may select either method according to their application scenarios.

### 7.2.1. Standard RJ45 Jack

Ethernet connector is a standard RJ45 jack, and the pin definition follows the Ethernet standard. Ethernet port supports CAT-5e cables or above, and the cable length can be up to 100m. Power can be supplied to the camera via Power over Ethernet (IEEE802.3af compatible).

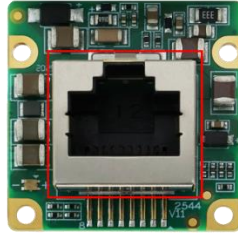

Figure 7-3 Standard RJ45 jack

### 7.2.2. FPC Interface

The FPC interface utilizes an FPC cable for connection, with the connector model specified as TF38-22S-0.5SV. The electrical characteristics of the signals comply with the 1000BASE-T/100BASE-TX IEEE 802.3 standard. In scenarios where the user-designed network port module lacks PoE functionality, power must be supplied via the 6-pin terminal's power port.

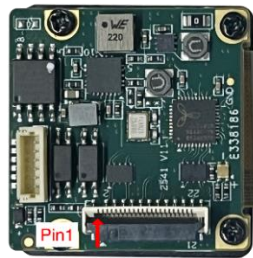

Figure 7-4 FPC connector

FPC Signal definition as follows:

Pin	Definition	Description	Pin	Definition	Description
1	GND	Ground	12	MDI2-	PHY Differential data
2	MDI0+	PHY Differential data	13	GND	Ground
3	GND	Ground	14	MDI3+	PHY Differential data
4	MDI0-	PHY Differential data	15	GND	Ground
5	GND	Ground	16	MDI3-	PHY Differential data
6	MDI1+	PHY Differential data	17	GND	Ground
7	GND	Ground	18	F_LED_RED	Red LED
8	MDI1-	PHY Differential data	19	VCC_4V5_POE	Power
9	GND	Ground	20	F_LED_GRE	Green LED
10	MDI2+	PHY Differential data	21	VCC_4V5_POE	Power
11	GND	Ground	22	GND	Ground

Table 7-2 FPC Connector Signal Definition of FPC camera

### 7.3. I/O Port

#### 7.3.1. I/O Connector Pin Definition

Diagram	Pin	Definition	Description
	1	POWER_IN	Camera external power, +12V DC~+24V DC
	2	Line0+	Opto-isolated input+
	3	Line2	GPIO input/output
	4	Line1+	Opto-isolated output+
	5	Line0-/Line1-	Line0-: Opto-isolated input - Line1-: Opto-isolated output -
	6	GND	PWR GND & GPIO GND

Table 7-3 Pin definition of 6-pin connector (back sight of camera)



The polarity of power cannot be reversed, otherwise, camera or other peripherals could burn out.

#### 7.3.2. I/O Electrical Features

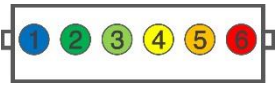
##### 7.3.2.1. Line0 (Opto-isolated Input) Circuit

Hardware schematics of opto-isolated input circuit as shown below.

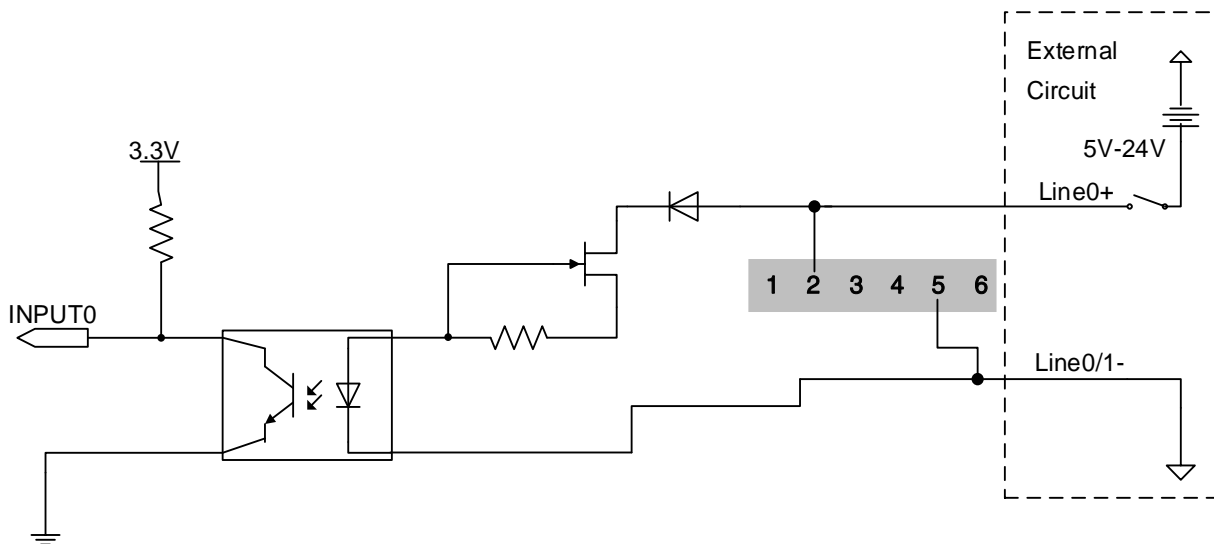

Figure 7-5 Opto-isolated input circuit

- Logic 0 input voltage: 0V~+2.5V (Line0+ voltage)
- Logic 1 input voltage: +5V~+24V (Line0+ voltage)
- Minimum input current: 7mA
- The status is unstable when input voltage is between 2.5V and 5V, which should be avoided

- When the external input voltage is 5V, there is no need for circuit-limiting resistance in the external input. But if there is a series resistance, please ensure the value is less than 90Ω. In order to protect the Line0+ while the external input voltage is higher than 9V, a circuit-limiting resistance is needed in the external input. The recommended values are shown in Table 7-4

External input voltage	Circuit-limiting resistance R <sub>limit</sub>	Line0+ input voltage
5V	Non or <90Ω	About 5V
9V	680Ω	About 5.5V
12V	1kΩ	About 6V
24V	2kΩ	About 10V

Table 7-4 Circuit-limiting resistor value

The connection method of the opto-isolated input circuit and the NPN and PNP photosensor as shown below. The relationship between the pull-up resistor value and the external power supply voltage is shown in Table 7-4.

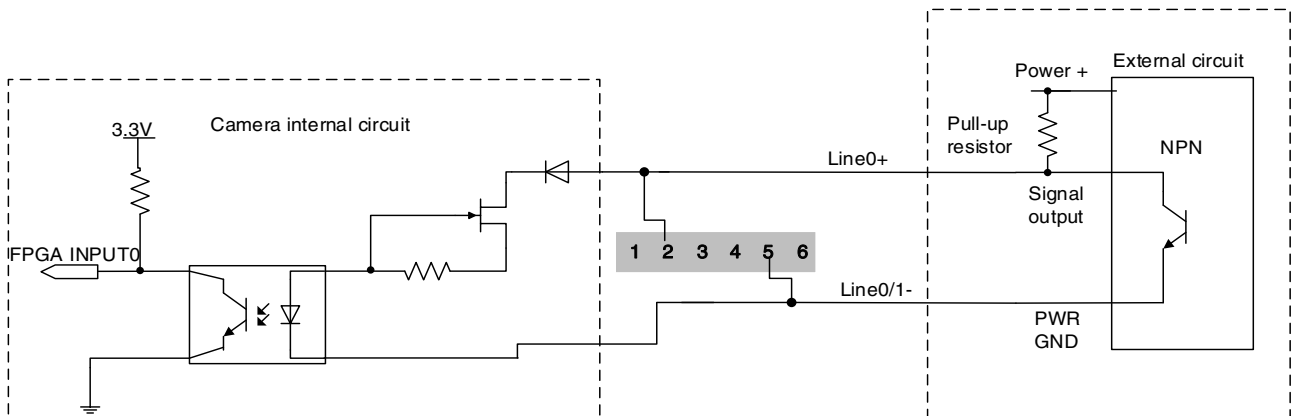

Figure 7-6 NPN photosensor connected to opto-isolated input circuit

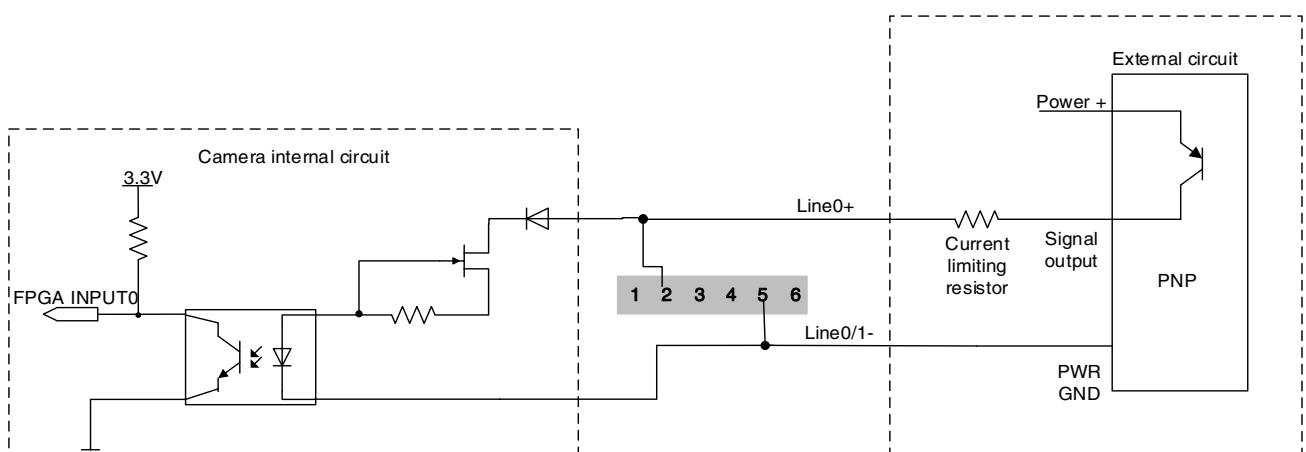

Figure 7-7 PNP photosensor connected to opto-isolated input circuit

- Rising edge delay: <math><50\mu\text{s}</math> (0°C~45°C), parameter description as shown in Figure 7-8
- Falling edge delay: <math><50\mu\text{s}</math> (0°C~45°C), parameter description as shown in Figure 7-8

- Different environment temperature and input voltage have influence on delay time of opto-isolated input circuit. Delay time in typical application environment (temperature is 25°C) is as shown in Table 7-5

Parameter	Test condition	Value (μs)		
Rising edge delay	VIN=5V	3.02	~	6.96
	VIN=12V	2.46	~	5.14
Falling edge delay	VIN=5V	6.12	~	17.71
	VIN=12V	8.93	~	19.73

Table 7-5 Delay time of opto-isolated input circuit in typical application environment

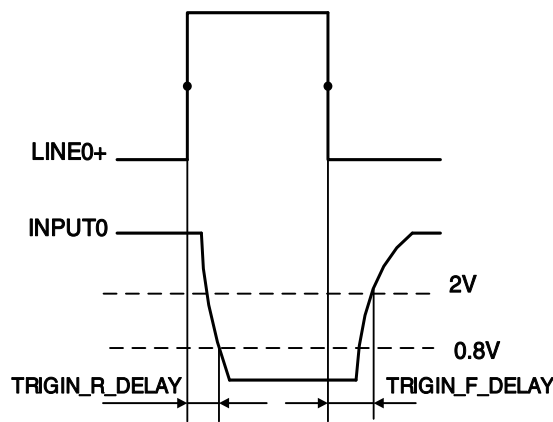

Figure 7-8 Parameter of opto-isolated input circuit

- Rising time delay (TRIGIN\_R\_DELAY): the response time from LINE0+ rises to 50% of amplitude to INPUT0 decreases to 0.8V
- Falling time delay (TRIGIN\_F\_DELAY): the response time from LINE0+ decreases to 50% of amplitude to INPUT0 rises to 2V

### 7.3.2.2. Line1 (Opto-isolated Output) Circuit

Hardware schematics of opto-isolated output circuit as shown below.

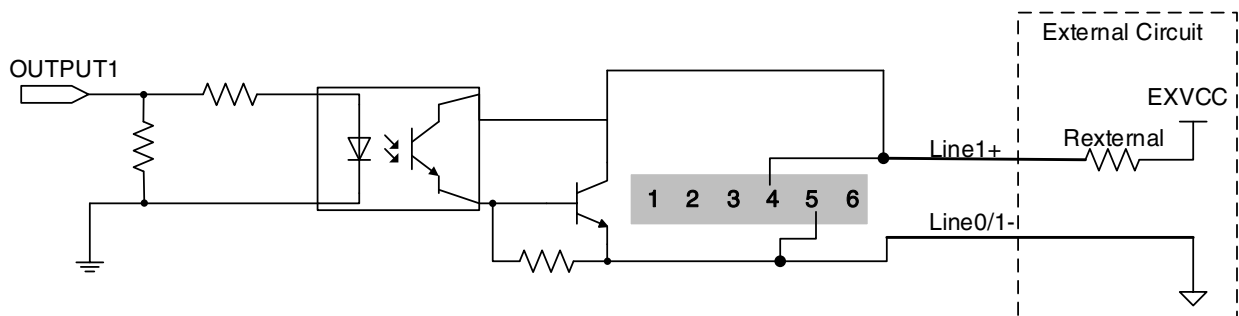

Figure 7-9 Opto-isolated output circuit

- Range of external voltage (EXVCC) is 5~24V

- Maximum output current of Line1 is 25mA
- Transistor voltage drop and output current of opto-isolated output circuit in typical application environment (temperature is 25°C) is as shown in Table 7-6

External voltage EXVCC	External resistance Rexternal	Transistor voltage drop (turn on, unit V)	Output current (mA)
5V	1kΩ	0.90	4.16
12V	1kΩ	0.97	11.11
24V	1kΩ	1.04	23.08

Table 7-6 Transistor voltage drop and output current of opto-isolated output circuit in typical application environment

- Rising time delay = tr+td: <50μs (0°C~45°C) (parameter description is shown in Figure 7-10)
- Falling time delay = ts+tf: <50μs (0°C~45°C) (parameter description is shown in Figure 7-10)
- Delay times in typical application conditions (environment temperature is 25°C) are shown in Table 7-7

Parameter	Test Condition	Value (μs)		
Storage time (ts)	External power is 5V, pull-up resistor is 1kΩ	6.16	~	13.26
Delay time (td)		1.90	~	3.16
Rising time (tr)		2.77	~	10.60
Falling time (tf)		7.60	~	11.12
Rising time delay = tr+td		4.70	~	13.76
Falling time delay = tf+ts		14.41	~	24.38

Table 7-7 Delay time of opto-isolated output circuit in typical application environment

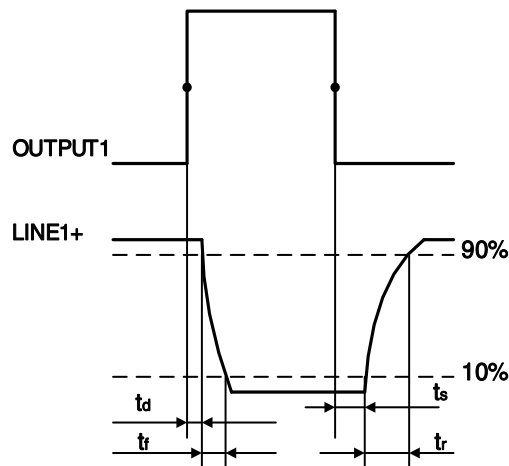

Figure 7-10 Parameter of opto-isolated output circuit

- Delay time ( $t_d$ ): the response time from OUTPUT1 rises to 50% of amplitude to LINE1+ decreases to 90% of amplitude
- Falling time ( $t_f$ ): the response time for LINE1+ to decrease from 90% of the amplitude to 10%
- Storage time ( $t_s$ ): the response time from OUTPUT1 decreases to 50% of amplitude to LINE1+ rises to 10% of amplitude
- Rising time ( $t_r$ ): the response time for LINE1+ to rise from 10% of the amplitude to 90%

7.3.2.3. Line 2 (Bidirectional) Circuit

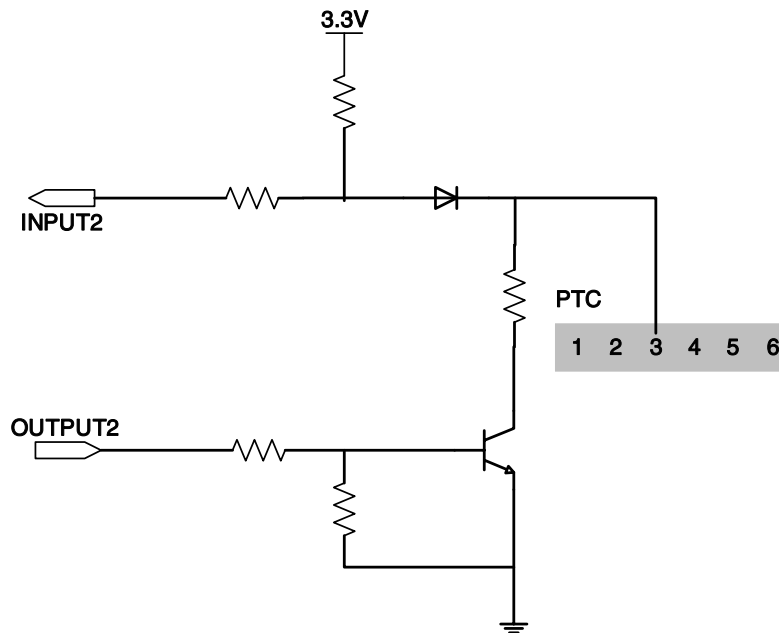

Figure 7-11 Line2 (bidirectional) circuit

7.3.2.3.1. Line2 is Configured as Input

When Line2 is configured as input, the internal equivalent circuit of camera as shown below:

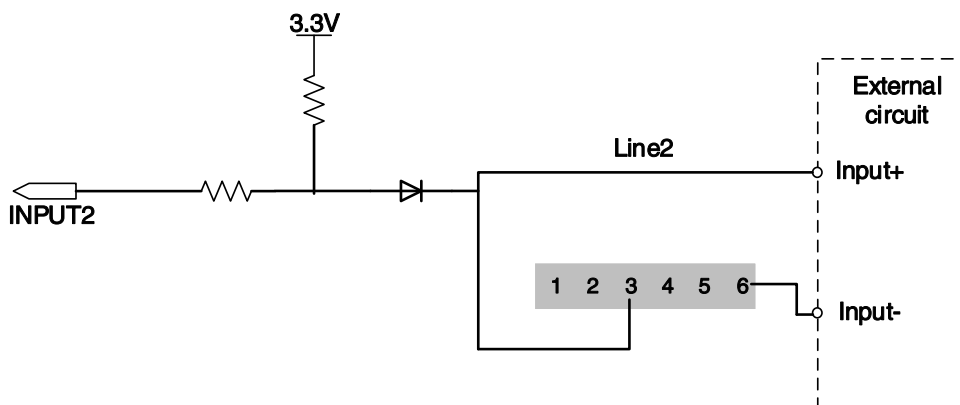

Figure 7-12 Internal equivalent circuit of camera when Line2 is configured as input



To avoid the damage of GPIO pins, please connect GND pin before supplying power to Line2.

- Logic 0 input voltage: 0V~+0.6V (Line2 voltage)
- Logic 1 input voltage: +1.9V~+24V (Line2 voltage)
- The status is unstable when input voltage is between 0.6V and 1.9V, which should be avoided
- When input of Line2 is high, input current is lower than 100uA. When input of Line2 is low, input current is lower than -1mA

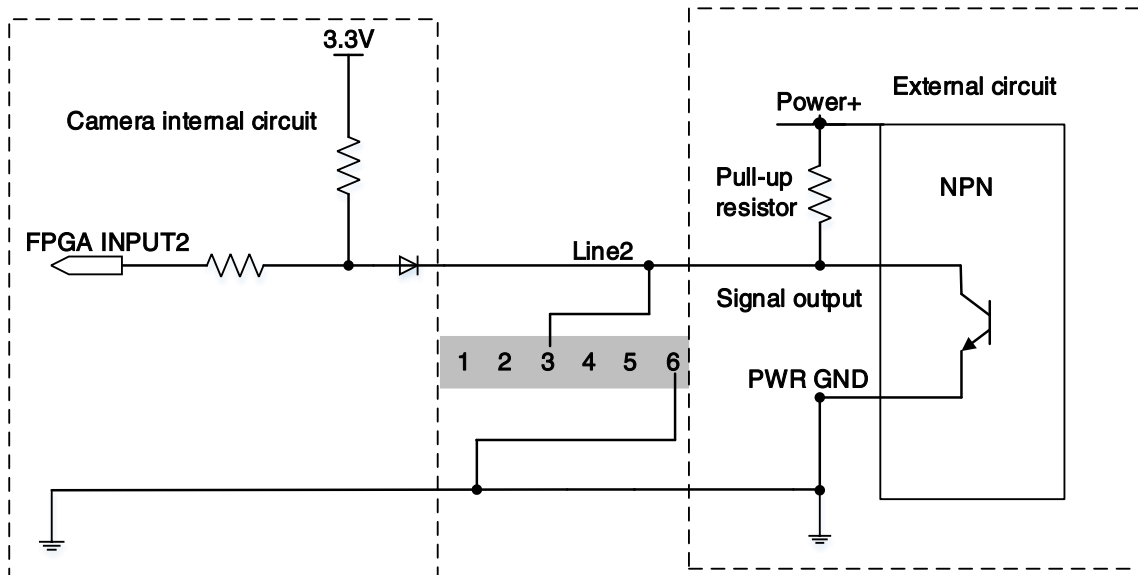

Figure 7-13 NPN photoelectric sensor connected to Line2 input circuit

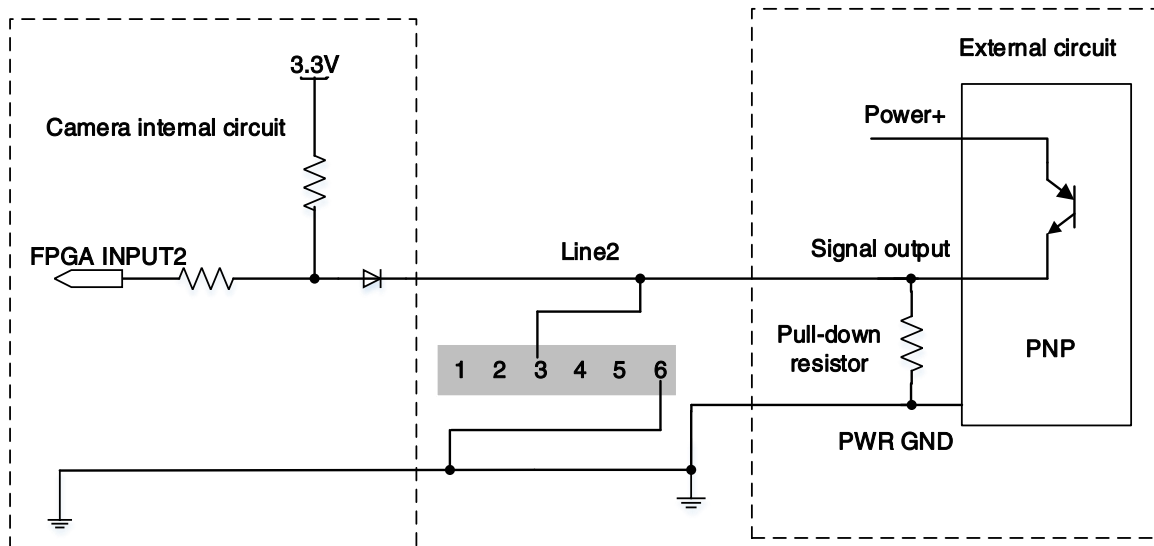

Figure 7-14 PNP photoelectric sensor connected to Line2 input circuit

- When Line2 is configured as input, if the corresponding output device is common-anode connected, pull-down resistor over 1K should not be used, otherwise the input voltage of Line2 will be over 0.6V and logic 0 cannot be recognized stably
- Input rising time delay: <math><2\mu\text{s}</math> (0°C~45°C), parameter description as shown in Figure 7-15
- Input falling time delay: <math><2\mu\text{s}</math> (0°C~45°C), parameter description as shown in Figure 7-15

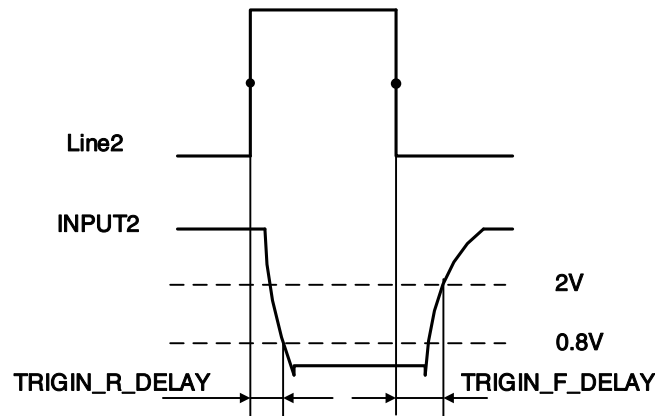

Figure 7-15 Parameter of Line2 input circuit

7.3.2.3.2. Line2 is Configured as Output

- Range of external voltage (EXVCC) is 5~24V
- Maximum output current of Line2 is 25mA, output impedance is 40Ω

Transistor voltage drop and output current in typical application conditions (temperature is 25°C) are shown in Table 7-8.

External voltage EXVCC	External resistance Rexternal	Transistor voltage drop (turn on, unit V)	Output current (mA)
5V	1kΩ	0.19	4.8
12V		0.46	11.6
24V		0.92	23.1

Table 7-8 Transistor voltage drop and output current of Line2 in typical conditions

- Rising time delay =  $t_r+t_d$ : <20μs (0°C~45°C) (parameter description as shown in Figure 7-16)
- Falling time delay =  $t_s+t_f$ : <20μs (0°C~45°C) (parameter description as shown in Figure 7-16)

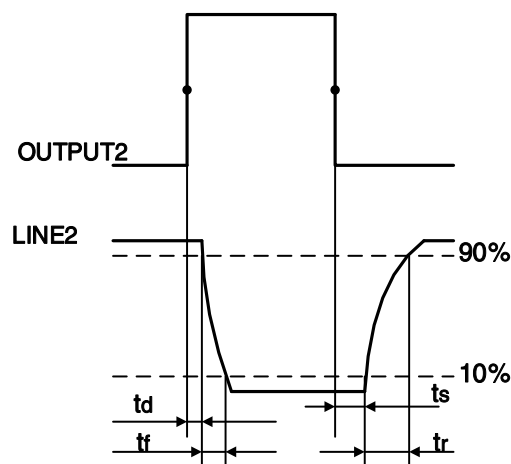

Figure 7-16 Parameter of Line2 output circuit

- Delay parameters are affected greatly by external voltage and external pull-up resistor, but little by temperature. Output delays in typical application conditions (temperature is 25°C) are shown in Table 7-9

Parameter	Test Conditions	Value (μs)		
Storage time (ts)	External power is 5V, pull-up resistor is 1kΩ	0.17	~	0.18
Delay time (td)		0.08	~	0.09
Rising time (tr)		0.11	~	0.16
Falling time (tf)		1.82	~	1.94
Rising time delay = tr+td		0.19	~	0.26
Falling time delay = tf+ts		1.97	~	2.09

Table 7-9 Delay time when GPIO is configured as output in typical conditions

When Line2 is configured as output, the internal equivalent circuit of camera as shown below, taking Line2 as an example.

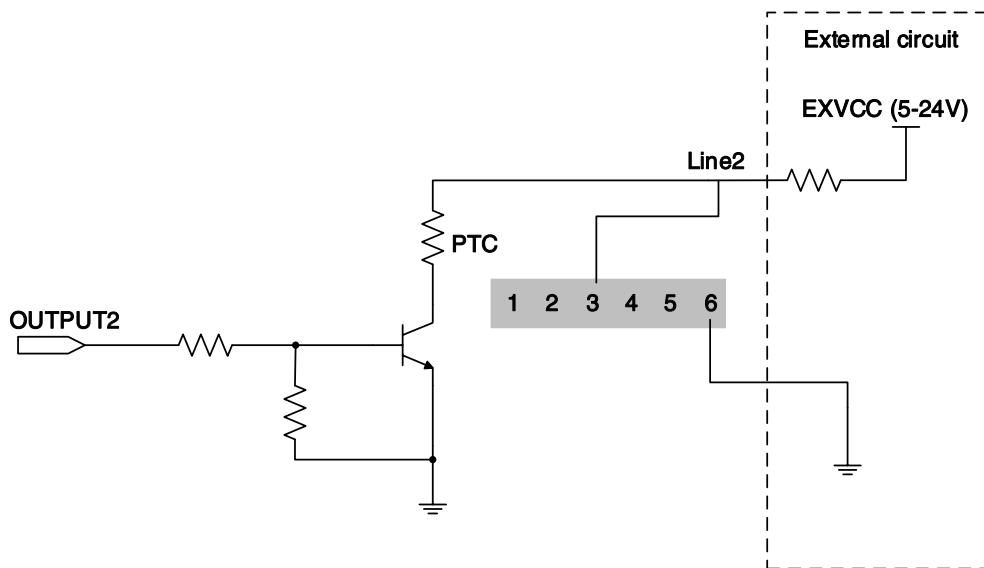

Figure 7-17 Internal equivalent circuit of camera when Line2 is configured as output

## 8. Features

### 8.1. I/O Control

#### 8.1.1. Input Mode Operation

##### 1) Configuring Line as input

The camera's Line0 is uni-directional opto-isolated input, Line2 is bi-directional lines which can be configured as input or output.

The camera's default input is Line0 when the camera is powered on. Line2 is input by default, which can be configured to be input or output by LineMode.

##### 2) Input Debouncer

In order to suppress the interference signals from hardware trigger, the camera has the hardware trigger filtering feature, including rising edge filtering and falling edge filtering. The user can set the trigger filter feature by setting the "TriggerFilterRaisingEdge" and the "TriggerFilterFallingEdge". The range of the trigger filter feature is [0, 5000]  $\mu$ s, step: 1 $\mu$ s.

Example 1: Setting the rising edge filter width to 1ms, the pulse width less than 1ms in the rising edge will be filtered out, as shown in Figure 8-1:

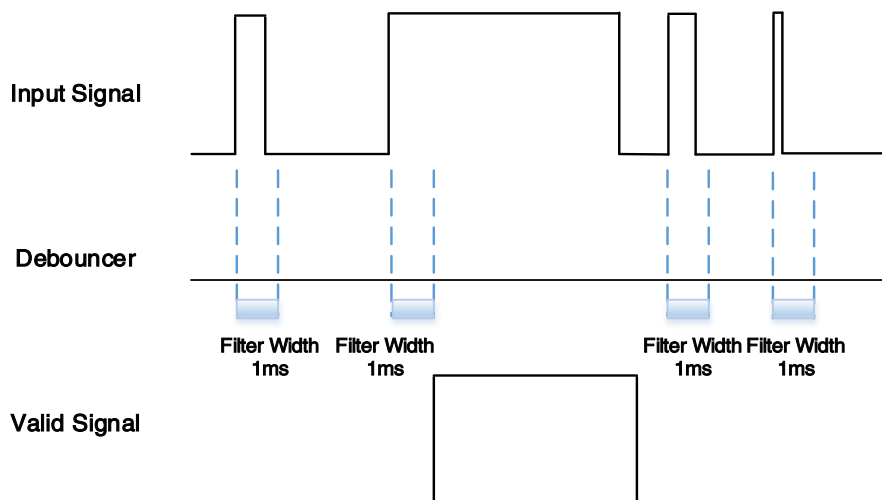

Figure 8-1 Input debouncer schematic diagram

##### 3) Trigger Delay

The camera has trigger delay feature. The user can set the trigger delay feature by setting "TriggerDelay". The range of the trigger delay feature is [0, 3000000]  $\mu$ s, step: 1 $\mu$ s.

Example 2: Setting the trigger delay value to 1000ms, and the trigger signal will be valid after 1000ms delay, as shown in Figure 8-2.

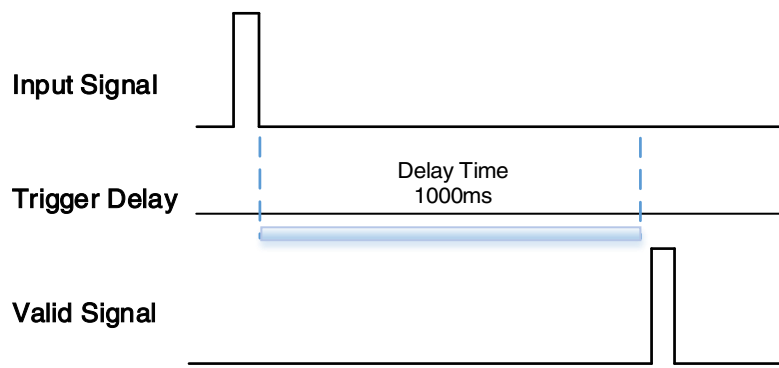

Figure 8-2 Trigger delay schematic diagram

#### 4) Input Inverter

The signal level of input lines is configurable for the camera. The user can select whether the input level is reverse or not by setting "LineInverter".

The default input line level is false when the camera is powered on, indicating that the input line level is not reversed. If it is set as true, indicating that the input line level is reversed. As shown in the Figure 8-3:

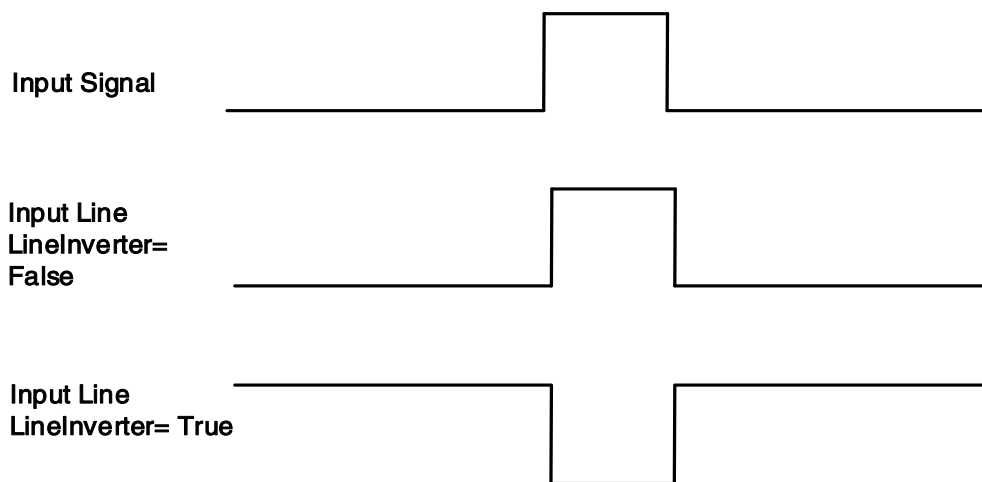

Figure 8-3 Setting input line reverse

### 8.1.2. Output Mode Operation

#### 1) Configuring Line as output

The camera's Line1 is a uni-directional opto-isolated output I/O, Line2 is bi-direction configurable I/Os.

The camera's default output is Line1 when the camera is powered on. Line2 can be configured to be output by changing the "LineMode" of this line.

Each output source of the three output lines can be configurable, and the output source includes: Strobe, UserOutput0, UserOutput1, UserOutput2, ExposureActive, FrameTriggerWait, AcquisitionTriggerWait.

The default output source of the camera is UserOutput0 when the camera is powered on.

What status (high or low level) of the output signal is valid depends on the specific external circuit. The following signal diagrams are described as examples of active low.

- Strobe

In this mode the camera sends a trigger signal to activate the strobe. The strobe signal is active low. After receiving the trigger signal, the strobe signal level is pulled low, and the pull-low time is the sum of the exposure delay time and the exposure time.

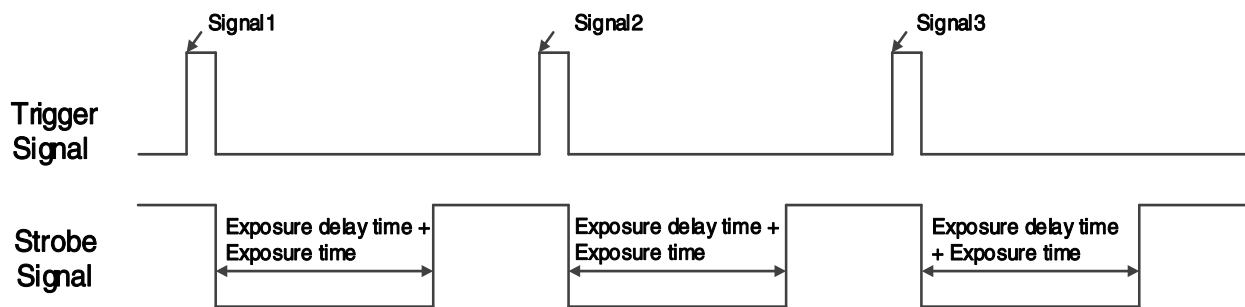

Figure 8-4 Strobe signal schematic diagram

- UserOutput

In this mode, the user can set the camera's constant output level for special processing, such as controlling the constant light source or the alarm light (two level types are available: high level or low level).

For example: select line2 as the output line, the output source is selected as UserOutput1, and the output value is defined as true.

"LineSelector" is selected as "line2", "LineMode" is set to "Output", "LineSource" is set to "UserOutput1", "UserOutputSelector" is selected as "UserOutput1", and "UserOutputValue" is set to "true".

- ExposureActive

You can use the "ExposureActive" signal to check whether the camera is currently exposing. The signal goes low at the beginning of the exposure and the signal goes high at the end of the exposure. For electronic rolling shutter cameras, the signal goes low when the exposure of the last line ends.

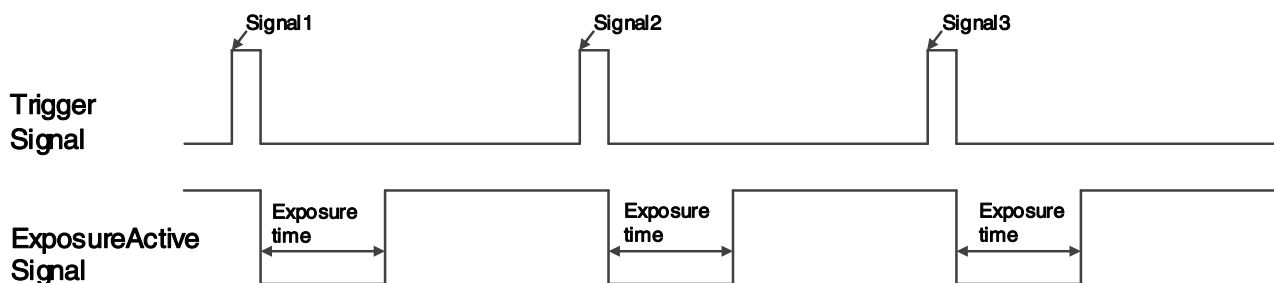

Figure 8-5 Global shutter "ExposureActive" signal schematic diagram

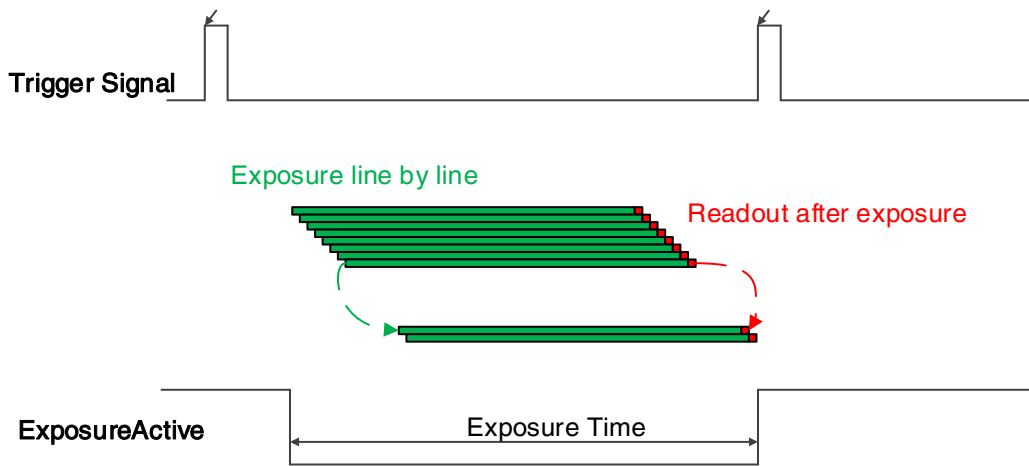

Figure 8-6 Electronic rolling shutter "ExposureActive" signal schematic diagram

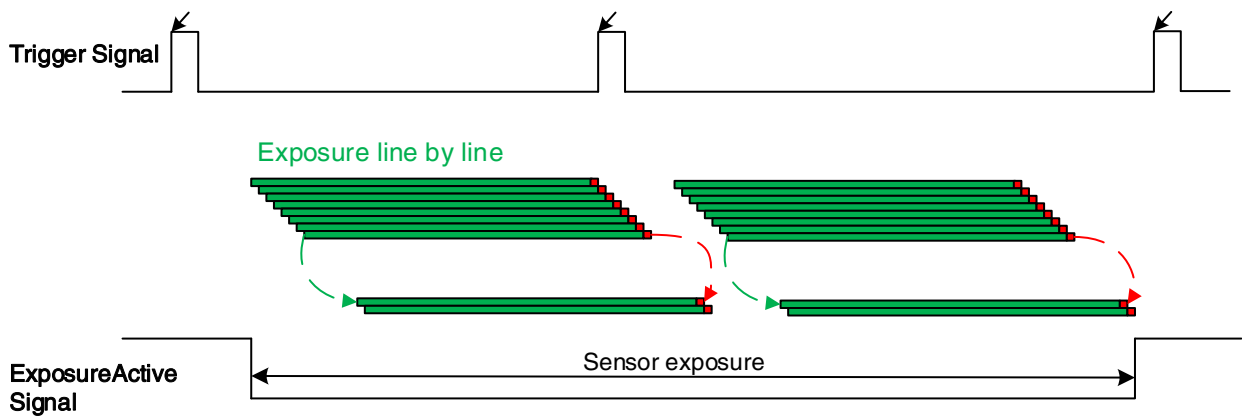

Figure 8-7 Electronic rolling shutter mode (overlapping exposure) "ExposureActive" signal schematic diagram



Figure 8-8 Global reset release shutter mode "ExposureActive" signal schematic diagram

This signal is also useful when the camera or target object is moving. For example, suppose the camera is mounted on a robotic arm that can move the camera to different position. Generally, it is not desirable for the camera to move during the exposure. In this case, you can check the exposure activity signal to know the exposure time so you can avoid moving the camera during this time.

- TriggerWait

The "TriggerWait" signal can be used to optimize the acquisition of the trigger image and to avoid excessive triggering.

It is recommended to use the "TriggerWait" signal only when the camera is configured for hardware trigger. For software trigger, please use the "AcquisitionStatus". When the camera is ready to receive a trigger signal of the corresponding trigger mode, the "TriggerWait" signal goes low. When the corresponding trigger signal is used, the "TriggerWait" signal goes high. It remains high until the camera is ready to receive the next trigger.

When the trigger mode is "FrameStart", the camera acquires only one frame of image when it receives the trigger signal. After receiving the trigger signal, the "FrameTriggerWait" signal is pulled low and the camera starts exposure transmission. After the transfer is complete, the "FrameTriggerWait" signal is pulled high.

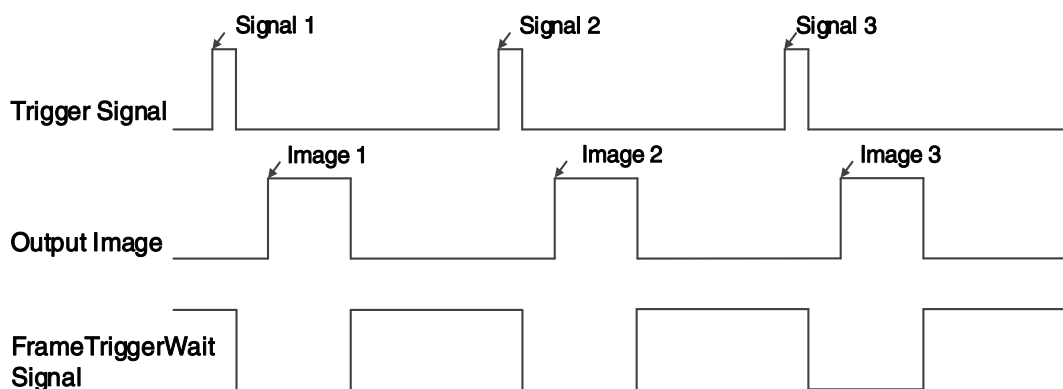

Figure 8-9 "FrameTriggerWait" signal schematic diagram

When the trigger mode is "FrameBurstStart", each time the camera receives a trigger signal, it will acquire multiple frames of image (the number of frames can be obtained by the function "AcquisitionFrameCount"). After receiving the trigger signal, the "AcquisitionTriggerWait" signal is pulled low and the camera starts the exposure transmission. When the transfer is completed, the "AcquisitionTriggerWait" signal will be pulled high.

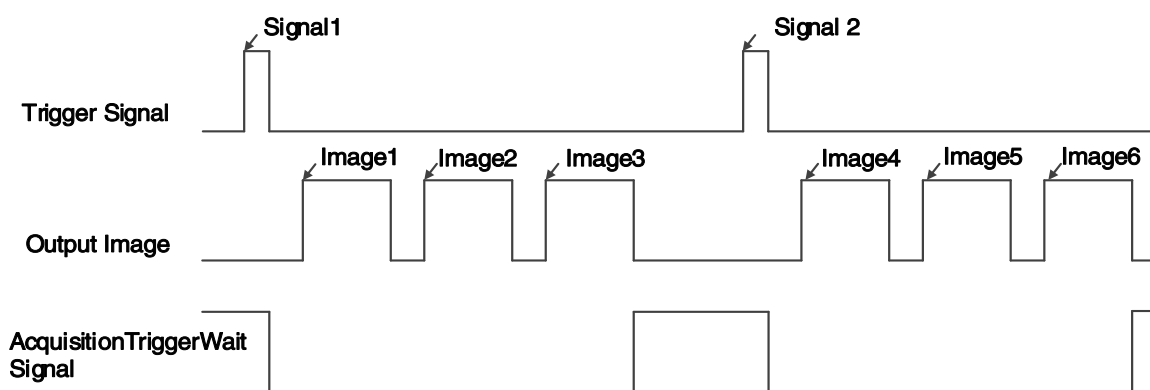

Figure 8-10 "AcquisitionTriggerWait" signal schematic diagram

When the trigger mode is "FrameBurstStart" ("FrameStart" mode is on), if the high-speed burst frames is set to 3, the camera will first send a "FrameBurstStart" trigger signal. After receiving the trigger signal, the "AcquisitionTriggerWait" signal is pulled low. Then three "FrameStart" trigger signals need to be sent continuously. Each time the camera receives a trigger signal, it transmits one frame image. After receiving the trigger signal, the "FrameTriggerWait" signal is pulled low and the camera will start exposure

transmission. The "FrameTriggerWait" signal will be pulled high after the transmission is completed. Only the first 3 FrameStart trigger signals are valid. When the transmission is completed, the "AcquisitionTriggerWait" signal will be pulled high.

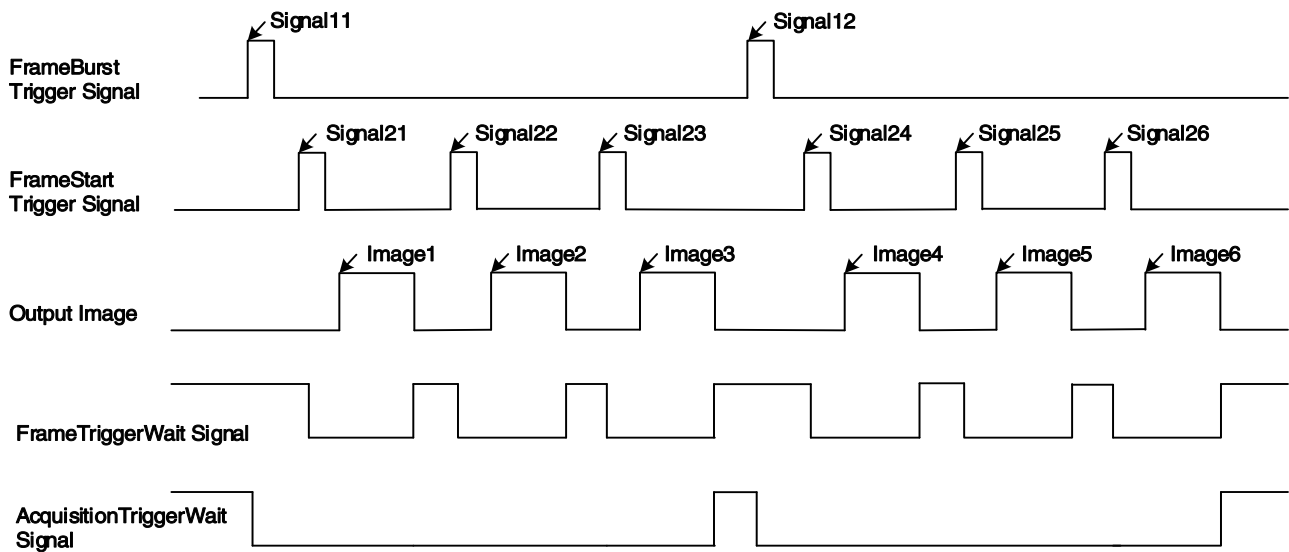

Figure 8-11 "TriggerWait" signal schematic diagram when "FrameBurstStart" and "FrameStart" enabled simultaneously

### 2) Setting the user-defined status for the output lines

The camera can select the user-defined output by setting "LineSource", by setting "UserOutputValue" to configure the output signal.

By setting "UserOutputSelector" to select UserOutput0, UserOutput1 or UserOutput2.

By setting "UserOutputValue" to set the user-defined output value, and the default value is false when the camera is powered on.

### 3) Output Inverter

In order to facilitate the camera I/O configuration and connection, the camera has the function of configurable output signal level. The user can select whether the output level is reverse or not by setting "LineInverter".

The default output signal level is false when the camera is powered on, indicating that the output line level is not reversed. If it is set as true, indicating that the output line level is reversed. As shown in the Figure 8-12.

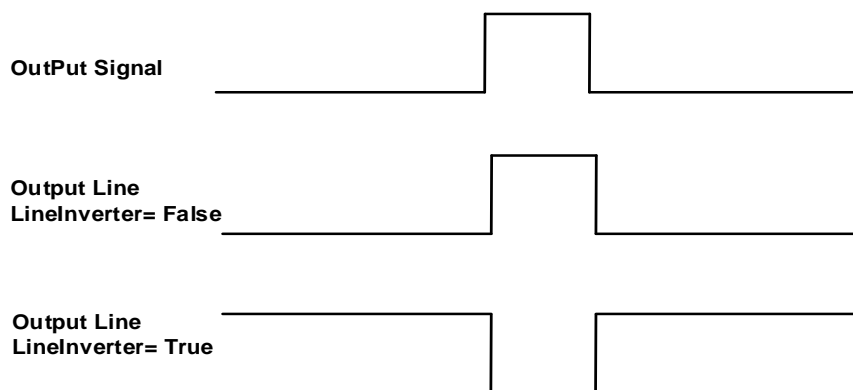

Figure 8-12 Set output line reversion

### 8.1.3. Read the LineStatus

#### 1) Read the level of single line

The camera can get the line's signal status.

When the device is powered on, the default status of Line0 is False, and the default status of Line1 and Line2 is True.

#### 2) Read all the lines level

The camera can get the current status of all lines. On the one hand, the signal status is the status of the external I/O after the reversal of the polarity. On the other hand, signal status level can reflect the external I/O level. The default value of VE2S-G-P camera is 0x6.

Line2	Line1	Line0
1	1	0

## 8.2. Image Acquisition Control

### 8.2.1. Acquisition Start and Stop

#### 8.2.1.1. Acquisition Start

It can send **Acquisition Start** command immediately after opening the camera. The acquisition process in continuous mode is illustrated in Figure 8-13, and the acquisition process in trigger mode is illustrated in Figure 8-14.

- **Continuous Acquisition**

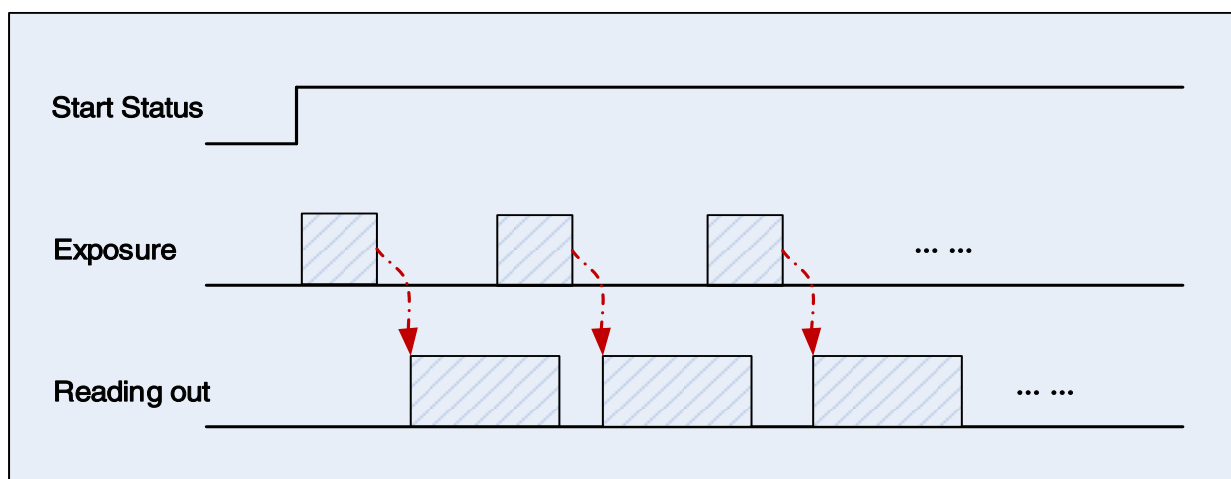

Figure 8-13 Continuous acquisition process

In continuous mode, a camera starts to expose and read out after receiving the **AcquisitionStart** command. The frame rate is determined by the exposure time, ROI and some other parameters.

- Trigger Acquisition

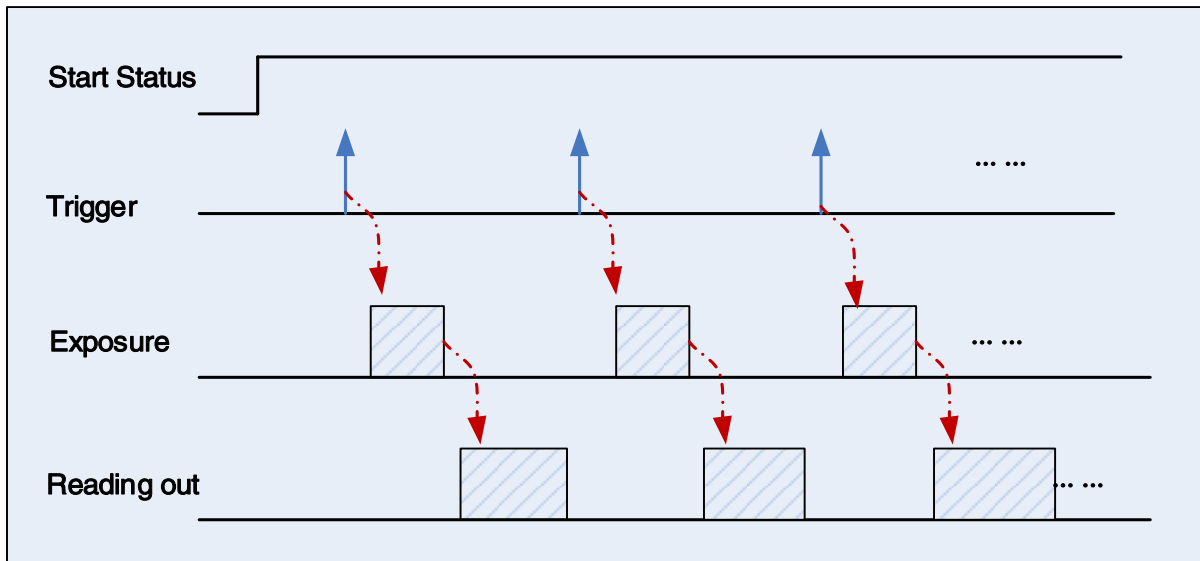

Figure 8-14 Trigger acquisition process

In trigger mode, sending **AcquisitionStart** command is not enough, a trigger signal is also needed. Each time a frame trigger is applied (including software trigger and hardware trigger), the camera will acquire and transmit a frame of image.

### 8.2.1.2. Acquisition Stop

It can send **AcquisitionStop** command to camera at any time. The acquisition stop process is irrelevant to acquisition mode. But different stop time will result in different process, as shown in Figure 8-15 and Figure 8-16.

- Acquisition stop during reading out

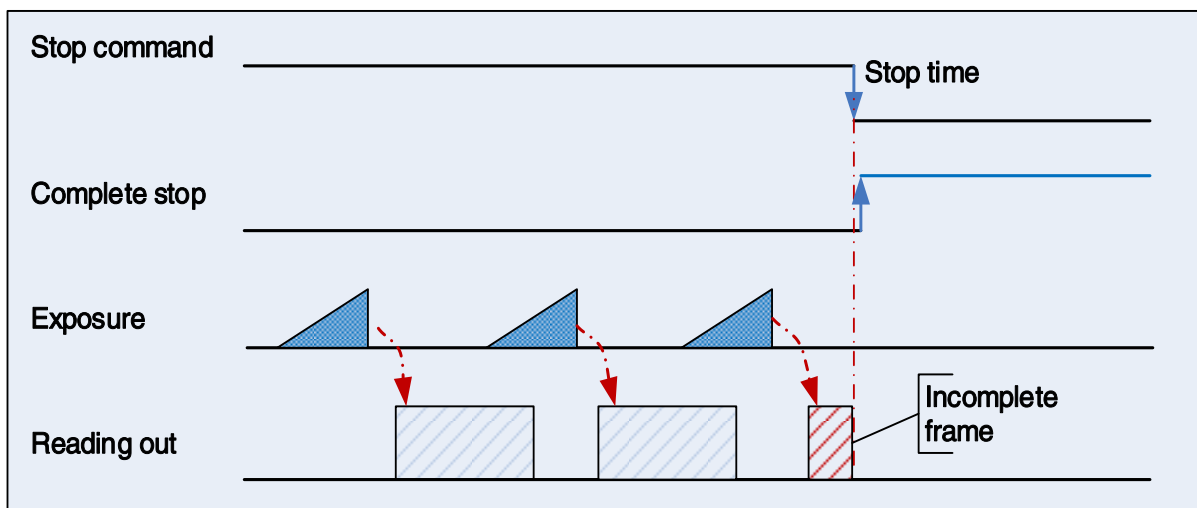

Figure 8-15 Acquisition stop during reading out

As shown in Figure 8-15, when the camera receives an acquisition stop command during reading out, it stops transferring frame data immediately. The currently transferred frame data is regarded as incomplete frame and will be discarded.

- Acquisition stop during blanking

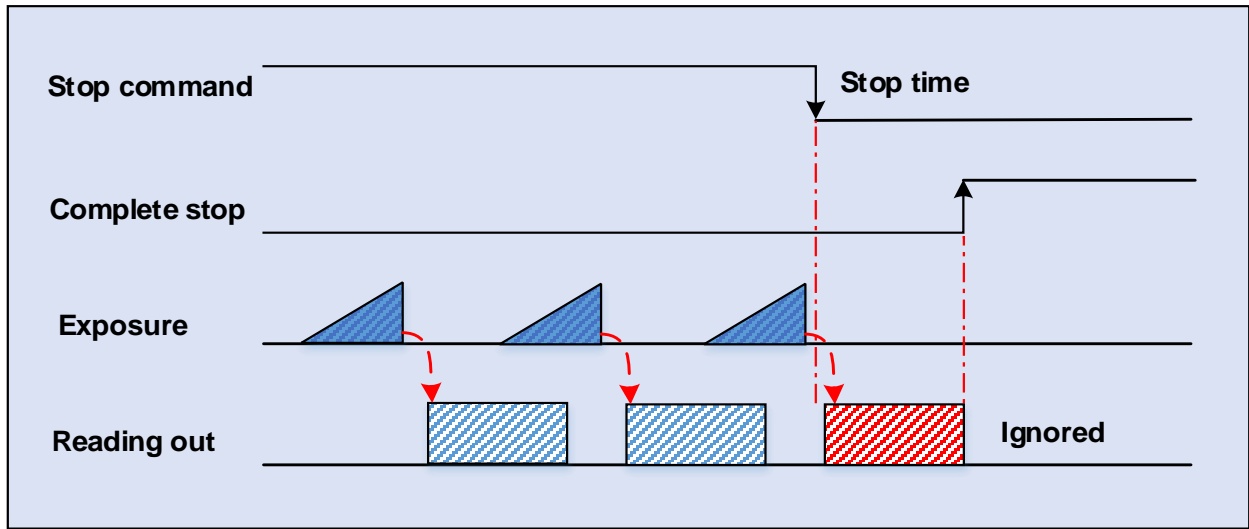

Figure 8-16 Acquisition stop during blanking

After the camera transferred a whole frame, the camera goes into wait state. When user sends an **AcquisitionStop** command in wait state, the camera will return to stop-finished state. The camera will not send any frames even if it is just going to start the next exposing.

- Acquisition stop during exposing

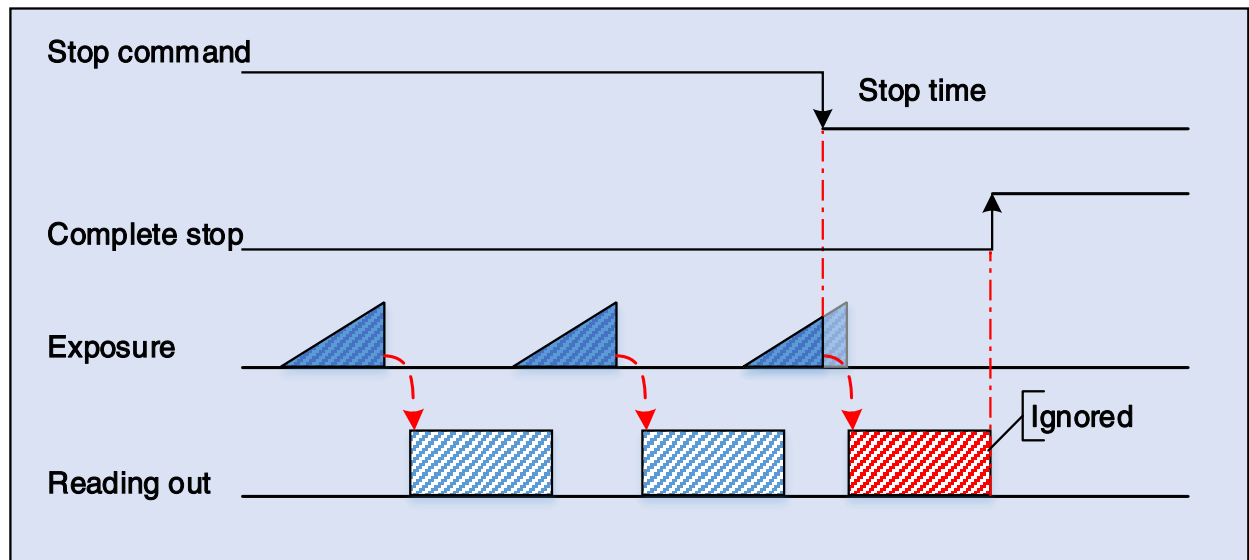

Figure 8-17 Acquisition stop during exposing

After the camera transferred a whole frame, the camera goes into exposure state. When user sends an **AcquisitionStop** command during exposing, the camera will immediately stop currently exposure state and return to stop acquisition state after finish the readout of incomplete frame. The camera will not send exception frames to users.

### 8.2.2. Acquisition Mode

Two camera acquisition modes are available: single frame acquisition mode and continuous acquisition mode.

- Single frame acquisition mode: In single frame acquisition mode, the camera will only acquire one frame of image at a time

1) When the trigger mode is set to On, the trigger type is arbitrary

After executing the **AcquisitionStart** command, the camera waits for a trigger signal, which may be a software trigger or a hardware trigger of the camera. When the camera receives the trigger signal and acquires an image, the camera will automatically stop image acquisition. If you want to acquire another frame of image, you must execute the **AcquisitionStart** command again.

2) When the trigger mode is set to Off

After executing the **AcquisitionStart** command, the camera acquires one frame of image and then automatically stops image acquisition. If you want to acquire another frame of image, you must execute the **AcquisitionStart** command again.



In single frame acquisition mode, you must execute the **AcquisitionStop** command to set the functions that cannot be set in the acquisition status, such as ROI, package size, etc.

- Continuous acquisition mode: In continuous acquisition mode, the camera continuously acquires and transmits images until the acquisition is stopped

1) When the trigger mode is set to On, the trigger type is **FrameStart**

After executing the **AcquisitionStart** command, the camera waits for a trigger signal, which may be a software trigger or a hardware trigger of the camera. Each time the camera receives a trigger signal, it can acquire a frame of image until the **AcquisitionStop** command is executed. It is not necessary to execute the **AcquisitionStart** command every time.

2) When the trigger mode is set to On, the trigger type is **FrameBurstStart**

After executing the **AcquisitionStart** command, the camera waits for a trigger signal, which may be a software trigger or a hardware trigger of the camera. Each time the camera receives a trigger signal, it can continuously acquire the set **AcquisitionFrameCount** frames of image. If the **AcquisitionStop** command is received during the acquisition process, the image being transmitted may be interrupted, resulting in the number of images acquired this time not reaching the **AcquisitionFrameCount** frames of image.

3) When the trigger mode is set to Off

After executing the **AcquisitionStart** command, the camera will continuously acquire images until it receives the **AcquisitionStop** command.



You can check if the camera is in the waiting trigger status by the camera's trigger wait signal or by using the acquisition status function.

### 8.2.3. Trigger Type Selection

Two camera trigger types are available: **FrameStart** and **FrameBurstStart**. Different trigger types correspond to their respective set of trigger configurations, including trigger mode, trigger delay, trigger source, trigger polarity, and software trigger commands.

- FrameStart trigger mode

The **FrameStart** trigger is used to acquire one image. Each time the camera receives a **FrameStart** trigger signal, the camera begins to acquire an image.

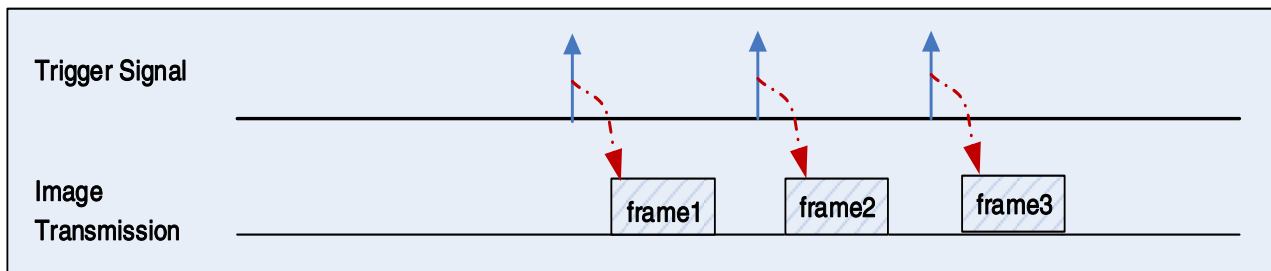

Figure 8-18 FrameStart trigger

- FrameBurstStart trigger mode

You can use the frame burst trigger to acquire a series of images ("continuous shooting" of the image). Each time the camera receives a **FrameBurstStart** trigger signal, the camera will start acquiring a series of images. The number of acquired image frames is specified by the "Acquisition burst frame count" parameter. The range of "Acquisition burst frame count" is 1~255, and the default value is 1.

For example, if the "Acquisition burst frame count" parameter is set to 3, the camera automatically acquires 3 images. Then, the camera waits for the next **FrameBurstStart** trigger signal. After receiving the next trigger signal, the camera will take another 3 images, and so on.

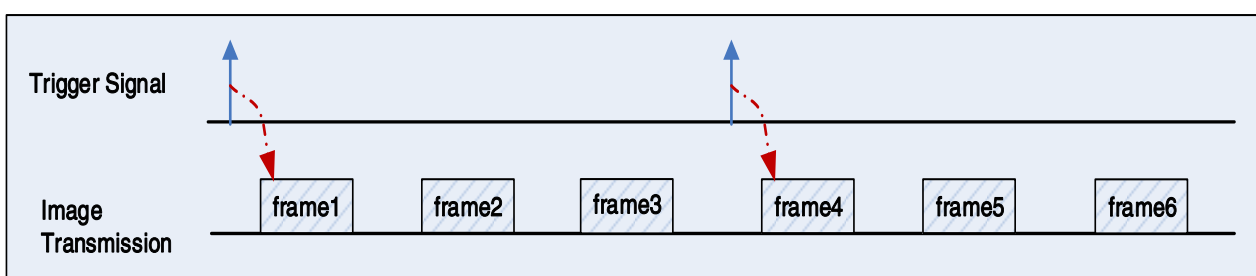

Figure 8-19 FrameBurstStart trigger

- **FrameStart** trigger mode and **FrameBurstStart** trigger mode set to ON at the same time

The **FrameStart** trigger mode and **FrameBurstStart** trigger mode can be set to ON at the same time. The camera will not acquire images immediately after receiving a **FrameStart/FrameBurstStart** trigger signal. The camera will wait for several **FrameStart** trigger signals after receiving the **FrameBurstStart** trigger signal and acquires images under the control of the **FrameStart** trigger signal. The number of acquired image frames is specified by the "Acquisition burst frame count" parameter.

For example, if the "Acquisition burst frame count" parameter is set to 3, after receive the **FrameBurstStart** trigger signal, the camera will waits for 3 **FrameStart** trigger signals and acquires 3 images. The remaining **FrameStart** trigger signals will be discarded, and so on.

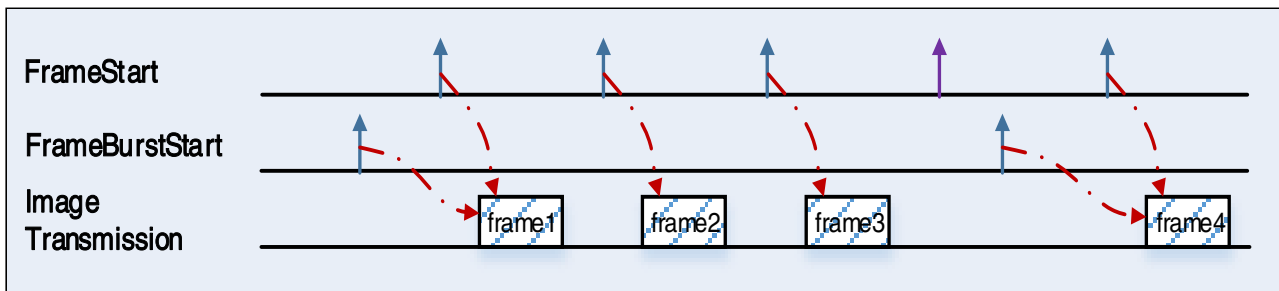

Figure 8-20 FrameStart trigger and FrameBurstStart trigger

### 8.2.4. Switching Trigger Mode

During the stream acquisition process, the user can switch the trigger mode of the camera without the **AcquisitionStop** command.

As shown below, switching the trigger mode at different positions will have different results.

- Switch trigger mode during frame reading out

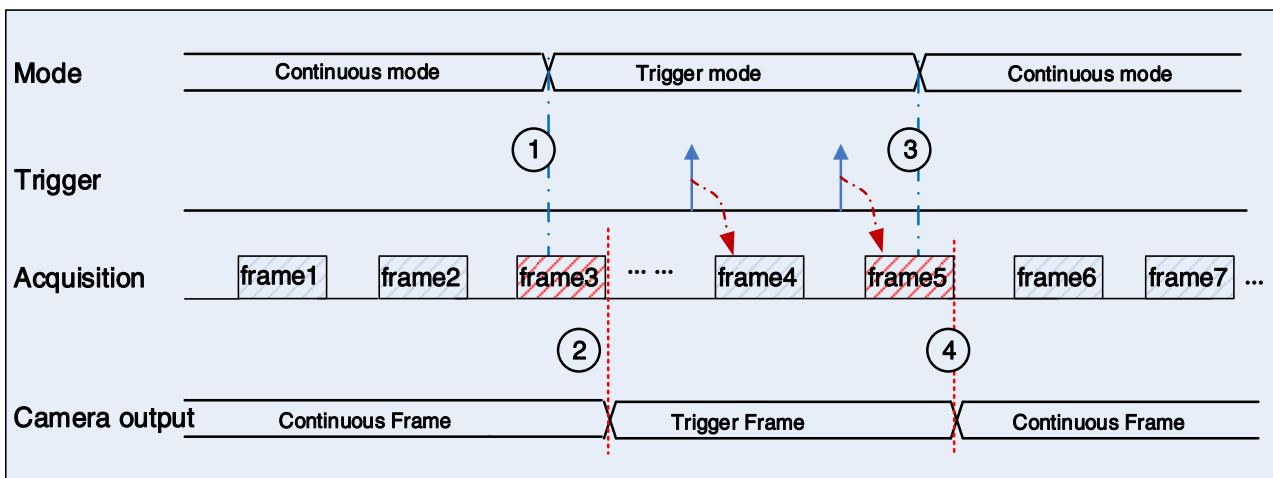

Figure 8-21 Switch trigger mode during frame reading out

As shown in Figure 8-21, the camera starts with trigger mode **OFF** after receiving acquisition start command.

At point 1, the camera gets a command of setting trigger mode **ON** while transferring the 3<sup>rd</sup> frame in trigger mode **OFF**. The trigger mode is not active until the 3<sup>rd</sup> frame is finished, at point 2, and then the trigger signal will be accepted. At point 3, the camera gets a command of switching back to **OFF**. It is also not active until the 5<sup>th</sup> frame is finished, it should wait a complete reading out. The camera switches from trigger mode to continuous mode at point 4, and then the camera works in continuous mode.

- Switch trigger mode during blanking (or exposure)

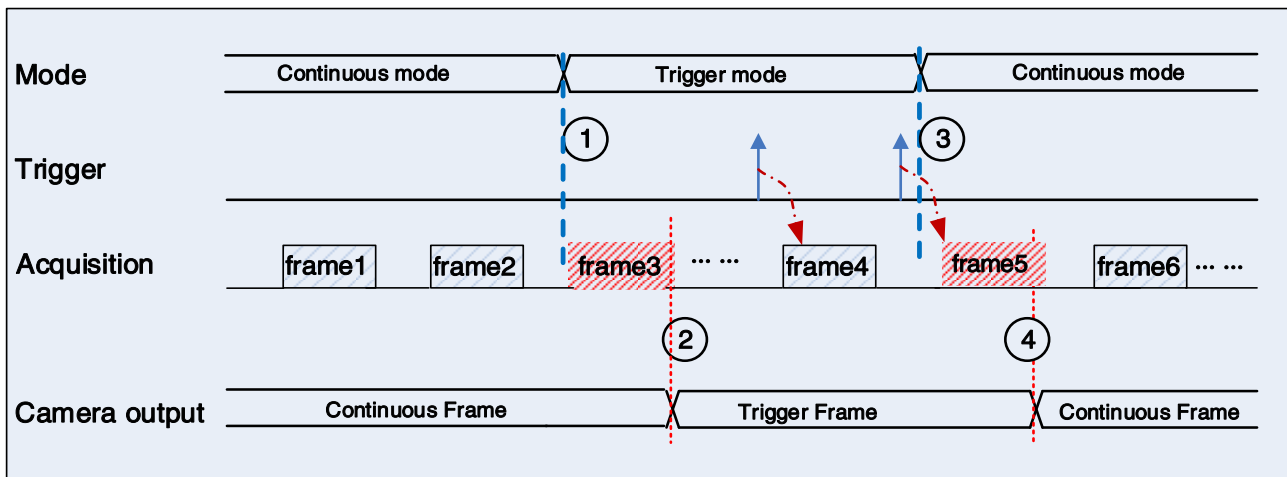

Figure 8-22 Switch trigger mode during blanking (or exposure)

As shown in Figure 8-22, the camera with trigger mode **OFF** begins after receiving an **AcquisitionStart** command.

At point 1, the camera gets a command of setting trigger mode **ON** while it is in wait state. The trigger mode is not active until the 3<sup>rd</sup> frame is finished (including exposure and reading out), i.e., point 2. Please note that the 3<sup>rd</sup> frame does not belong to trigger mode. All trigger frames need trigger signals or soft-trigger commands. At point 3, the camera gets a command of switching back to continuous mode. It is also not active until the 5<sup>th</sup> frame is finished, it should wait a complete frame. The camera switches from trigger mode to continuous mode at point 4, and then the camera works in continuous mode.

### 8.2.5. Continuous Mode and Configuration

- Continuous mode configuration

The default value of **Trigger Mode** is **OFF** in default user set. If the camera is opened with default user set, the camera works in continuous mode directly. Otherwise, user can set **Trigger Mode OFF** to use continuous mode.

Other parameters also can be changed in **Trigger Mode OFF**.

- Continuous mode features

In continuous acquisition mode, the camera acquires and transfers images according to camera parameter set.



In continuous mode, ROI size, packet delay may have effects on frame rate.

### 8.2.6. Acquisition Burst Mode

Acquisition burst mode setting is only applicable to trigger mode, which includes standard mode and high speed mode.

Standard mode: GigE or USB3 interface is limited by the bandwidth.

High speed mode: GigE or USB3 interface is not limited by the bandwidth. Acquisition is conducted according to the maximum acquisition capacity of the sensor, and the frame rate is generally greater than the current transmission capacity. It is mainly used in conjunction with the UserControlled mode (section 8.5.6) and FrameBurstStart mode (section 8.2.3).

For specific about the example programs, please refer to "C SDK Programming Reference Manual" relevant section.

Because of the transfer control mode is under user control, especially when multiple frames are transmitted at one time, the transmission is carried out according to the maximum transmission speed of the interface. Due to the different performance of the NIC, frame dropping may occur during long operation, so the IPG (Inter Packet Gap, default value: 0) needs to be increased.



The IPG settings depend on the following factors:

- 1) Frame settings in a single transmission.
- 2) Interval between two transmissions (100ms or above recommended).
- 3) Packet Size (8164 recommended, NIC jumbo frame mode).

### 8.2.7. Software Trigger Acquisition and Configuration

#### ● Software trigger acquisition configuration

The camera supports software trigger acquisition mode. Three steps followed should be ensured.

- 1) Set the Trigger Mode to ON.
- 2) Set the Trigger Source to Software.
- 3) Send TriggerSoftware command.

All the software trigger commands are sent by the host through the Gigabit Ethernet bus, to trigger the camera to capture and transmission images.

#### ● Software trigger acquisition features

In software trigger acquisition mode, the camera begins to acquire one image after receiving software trigger commands. In general, the number of frames is equal to the number of software trigger commands. The relative features are illustrated below:

- 1) In software trigger acquisition mode, if the trigger frequency is lower than permissible maximal FPS (Frame per Second) of the camera, the current frame rate is trigger frequency. If the trigger frequency is higher than permissible maximal FPS (Frame per Second) of the camera, some software triggers are ignored and the current frame rate is lower than trigger frequency.
- 2) The trigger delay feature can control the camera delay interval between your triggers and the camera acquiring frames. The default value of trigger delay time is zero.

## 8.2.8. Action Acquisition and Configuration

### 8.2.8.1. Action

The Action camera feature allows you to execute actions on multiple GigE cameras at roughly the same time by using a single broadcast protocol message.

If you want to execute actions on multiple cameras at exactly the same time, use the Scheduled Action Commands feature instead.

If you want to send action commands using the GalaxyView, use the "Action Command Window" plugin

- How it works

Action commands are broadcast protocol messages that you can send to multiple devices in a GigE network.

Each action protocol message contains the following information:

- **BroadcastAddress:** A string variable used to define where the action command will be broadcast to. When using the GXSDK, the broadcast address must be in dot notation, e.g., "255.255.255.255" (all adapters), "192.168.1.255" (all devices in a single subnet 192.168.1.xxx), or "192.168.1.10" (a single device).
- **ActionDeviceKey:** A 32-bit number used to authorize the execution of an action command on the camera. If the action device key on the camera and the action device key in the protocol message are identical, the camera executes the corresponding action.
- **ActionGroupKey:** A 32-bit number used to define a group of devices on which an action should be executed. If the action group key on the camera and the action group key in the protocol message are identical, the camera executes the corresponding action.
- **ActionGroupMask:** A 32-bit number used to filter out a sub-group of cameras belonging to a group of cameras. The cameras belonging to a sub-group execute an action at the same time. The filtering is done using a logical bitwise AND operation on the group mask number of the action command and the group mask number of a camera. If both binary numbers have at least one common bit set to 1 (i.e., the result of the AND operation is non-zero), the corresponding camera belongs to the sub-group. Example: Assume that a group of six cameras is installed on an assembly line. To execute actions on specific sub-groups, the following group mask numbers have been assigned to the cameras (sample values):

Camera	Group Mask Number (Binary)	Group Mask Number (Decimal)
1	000001	1
2	000010	2
3	000100	4
4	001000	8
5	010000	16
6	100000	32

Scenario 1: An action command with an action group mask of 7 (000111) executes an action on cameras 1, 2, and 3.

Scenario 2: An action command with an action group mask of 44 (101100) executes an action on cameras 3, 4, and 6.

For cameras, the ActionDeviceKey, ActionGroupKey, and ActionGroupMask must all be matched successfully to respond to an Action command.

- Using Action Commands

- 1) Make sure that camera support Action feature and all cameras on which you want to configure action commands are installed and configured in the same network segment.
- 2) Open the camera configuration: ActionDeviceKey, ActionGroupKey, ActionGroupMask.
- 3) Set the TriggerMode to On, TriggerSource to Action0.
- 4) Send Acquisition Start command
- 5) Send broadcast command, which contains the key information: BroadcastAddress, ActionDeviceKey, ActionGroupKey, and ActionGroupMask.

#### 8.2.8.2. Scheduled Action

The Scheduled Action camera feature allows you to execute actions on multiple GigE cameras at roughly the same time by using a single broadcast protocol message.

The difference with the Action function is that Action allows you to execute actions on multiple cameras at roughly the same time (millisecond level), while Schedule Action allows you to execute actions on multiple cameras at exactly the same time (sub-microsecond level). This function must be used in conjunction with the PTP function.

- How it works

The basic parameters of the Scheduled Action feature are the same as for the Action feature: BroadcastAddress, ActionDeviceKey, ActionGroupKey, ActionGroupMask. In addition to these parameters, the Scheduled Action Command feature uses the ActionTime parameter.

➤ ActionTime: A 64-bit GigE Vision timestamp used to define when the action is to be executed. The action is executed as soon as the internal timestamp value of a camera reaches the specified value. With the PTP enabled, the timestamp value is synchronized across all cameras in the network. Assume you issue a scheduled action command with the action time set to 100000000000. The action will be executed as soon as the timestamp value of all cameras in the specified network segment reaches 100 000 000 000. (If the action time is less than the camera's current timestamp, the camera will execute this command immediately and process it as Action commanded.)

➤ Using Scheduled Action Commands

- 1) Make sure that camera support Action feature and all cameras on which you want to configure action commands are installed and configured in the same network segment.

- 2) Open the camera configuration: ActionDeviceKey, ActionGroupKey, ActionGroupMask.
- 3) Set the TriggerMode to On, TriggerSource to Action0.
- 4) Set PtpEnable to True, wait PTP Status to stabilize and then continue, see the 8.2.9 for details.
- 5) Send Acquisition Start command.
- 6) Send broadcast command, which contains the key information: BroadcastAddress, ActionDeviceKey, ActionGroupKey, ActionGroupMask and ActionTime.

### 8.2.8.3. Acquisition and Reception

Using a single-port NIC + switch, the topology is that the PC's single-port NIC connects to multiple cameras through a switch, so that the cameras are on the same LAN as the PC.

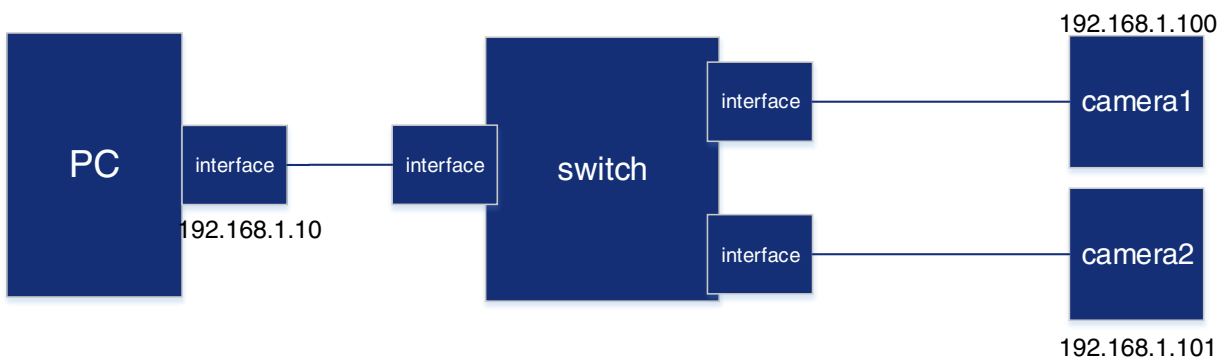

If you want to execute actions on multiple cameras at exactly the same time (microsecond level), it is recommended to use switches with PTP function and use the Scheduled Action feature to trigger acquisition.

If you want to execute actions on multiple cameras at roughly the same time (millisecond level), it is recommended to use ordinary switches and use the Action feature to trigger acquisition.

#### Scenario 1: GigE NIC + GigE switch (Low frame rate for acquisition)

Multiple cameras sharing Gigabit bandwidth in the same LAN and outputting images at the same time, it is necessary to make sure that the instantaneous bandwidth does not exceed the total bandwidth of the NIC, or else there will be incomplete frame problems. Therefore, when users adopt this hardware configuration, they need to reduce the bandwidth of the cameras through the “GevSCPD” function, so that the total bandwidth of data transmission of all the cameras is within the bandwidth of the NIC.

#### Scenario 2: 10GigE NIC + 10GigE switch (High frame rate for acquisition)

10GigE switch can be a 10G NIC + N 1G/2.5G port configuration, such as 8 GigE cameras into the switch's 8 1G ports, the PC side of the use of a 10G single-port NIC can be captured at the full frame rate, do not need to adjust the “GevSCPD”.

- 1) If the PC network port is configured with multiple IPs, you must specify the IP that sends the Action. If you do not specify the IP, it will cause each IP to send the Action command once, and the camera will receive multiple Action commands, and multiple triggers may occur.
- 2) If the actual use of the camera is more, and the acquisition bandwidth is larger, the switch forwarding performance requirements are higher, there may be PTP accuracy jitter, and then you need to increase the "AnnounceReceiptTimeout". For example, change it from 8 seconds to 30 seconds or 60 seconds.
- 3) If you use Schedule Action, the minimum value of delay time you set should theoretically cover the transmission time of the command on the network. If the network condition is smooth, it will be a few milliseconds at mos. If the network condition is bad (such as the performance of the switch is insufficient, the ability to forward broadcast packets is insufficient, etc.), it will take more than 10 milliseconds or tens of milliseconds.

### 8.2.9. Precision Time Protocol (PTP)

The Precision Time Protocol (PTP) camera feature allows you to synchronize multiple GigE cameras in the same network.

The IEEE 1588 standard defines the protocol. DAHENG IMAGING cameras support IEEE 1588-2008, also known as Version 2.

 The precision of the PTP synchronization depends to a large extent on your network hardware and setup. For maximum precision, choose high-quality network hardware, and use PTP-enabled network switches.

The PTP feature enables a camera to use the Schedule Action feature.

#### 8.2.9.1. Enable PTP

- 1) Set the PtpEnable to True
- 2) Wait until all PTP network devices are sufficiently synchronized. Depending on your network setup, this may take a few seconds or minutes. You can determine when the devices are synchronized by checking the status of the PTP clock synchronization.

 On VE2S-G-P cameras, enabling PTP clock synchronization changes the camera's internal tick frequency from 125 MHz to 1 GHz. The GevSCPD parameter values are adjusted automatically.

#### 8.2.9.2. Checking the Status of the PTP Synchronization

Phase 1: master and slave roles, you can read PtpStatus to know the PTP roles of the current camera, DAHENG IMAGING camera will assign the master and slave roles in about 8 seconds.

Phase 2: The slave camera and the master camera are synchronized. You can read the PtpOffsetFromMaster to know the slave camera's clock deviates from the clock of the master until the offsets are below a certain threshold according to your requirements, for example, less than 1000ns.



Due to the fact that the clock is adjusted continuously, It is recommended that you observe the range of maximum values of PtpOffsetFromMaster within a specified time window (e.g. 2 minutes). Before each read of PtpOffsetFromMaster, send the PtpDataSetLatch command on camera to take a "snapshot" of the camera's current PTP state.

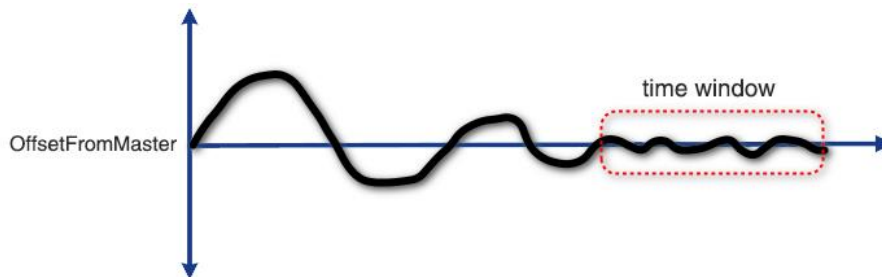

### 8.2.9.3. PTP Status

PtpStatus: Read-only. Returns the current PTP state of the camera.

PTP status: Listening, PreMaster, Master, Slave

Status transition diagram:

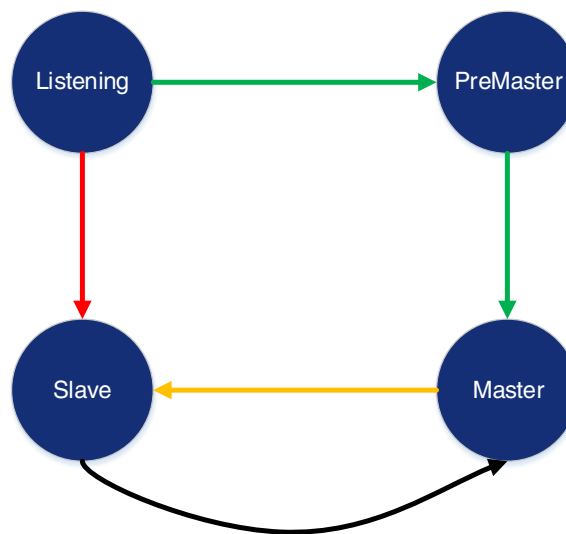

- Red line: When there is already a master clock in the LAN, the camera will start up in the Listening state at this point. After Executing the best master clock algorithm, it was determined that the camera's PtpStatus is more appropriately to be set to slave.
- Green line: When there is already a master clock in the LAN, the camera will start up in the Listening state at this point. After Executing the best master clock algorithm, it was determined that the camera's PtpStatus is more appropriately to be set to Master. The PtpStatus of the camera will be set to Premaster and then Master.
- Green line: When there is no master clock in the LAN, the camera will start up in the Listening state at this point. Then the PtpStatus of the camera will be set to Premaster and then Master, and then executing the process of the yellow line.

- Yellow line: When there are multiple Master clocks in the LAN at the same time, after the best master clock algorithm determines that only one Master clock will be retained, and the other Master clocks will directly become Slave clock.
- Black line: When the Master clock in the LAN suddenly fails, all Slave clocks will become Master clock and then executing the process of the yellow line.

#### 8.2.9.4. Announce Receipt Timeout

After the master-slave relationship of the PTP device is determined, the master-slave will send packets to maintain this relationship at 2-second intervals. If the slave camera does not receive the master's Announce packet within the "AnnounceReceiptTimeout", it will cause the slave camera to switch to the master and re-synchronize. This may be due to an instantaneous blockage in the network environment, resulting in the loss of the Announce packet. The master-slave relationship will be restored when the network is smooth but it does cause a short period of accuracy jitter on the slave camera. Users can set the timeout time appropriately according to the current network conditions. The factory default value is 8 seconds, if the current network environment is relatively poor, you can consider adjusting to 30 seconds or 60 seconds.

#### 8.2.9.5. PTP Data Latch

Users can send PtpDataSetLatch command and read out the camera's current PTP status values.

- PtpOffsetFromMaster: Read-only, Returns the value of how much the timestamp of the slave deviates from the timestamp of the master, unit: ns
- PtpClockID: Read-only, Returns the current clock ID of the camera
- PtpParentClockID: Read-only, Returns the current parent clock ID of the camera
- PtpGrandmasterClockID: Read-only, Returns the current Grandmaster clock ID of the camera

### 8.2.10. Hardware Trigger Acquisition and Configuration

#### ● Hardware trigger acquisition configuration

The camera supports hardware trigger acquisition mode. Three steps followed should be ensured:

- 1) Set the Trigger Mode to ON.
- 2) Set the Trigger Source to Line0 or Line2.
- 3) Connect hardware trigger signal to Line0.

If the Trigger Source is set by Line2, it should be ensured that the corresponding Line is set as Input.

Please refer to section 8.1.1 for more information of the programmable GPIO interfaces.

#### ● Hardware trigger acquisition features

The relative features about the camera's trigger signal process are illustrated below:

- 1) The polarity of lines can be set to inverted or not inverted, and the default setting is not inverted.
- 2) Improper signal can be filtered by setting appropriate value to trigger filter. Raising edge filter and falling edge can be set separately. The range is from 0 to 5000  $\mu\text{s}$ . The default configuration is not use trigger filter.
- 3) The time interval between trigger and exposure can be through the trigger delay feature. The range of time interval covers from 0 to 3000000 $\mu\text{s}$ . The default value of trigger delay time is zero.

The features, like trigger polarity, trigger delay and trigger filter, can be select in the GalaxyView.



The camera's trigger source Line0 use opto-isolated circuit to isolate signal. Its internal circuit delay trigger signal and rising edge's delay time is less than falling edge's. There are a dozen clock cycles delay of rising edge and dozens clock cycles delay of falling edge. If you use Line0 to trigger the camera, the positive pulse signal's positive width will be wider (about 20 $\mu\text{s}$ -40 $\mu\text{s}$ ) and the negative pulse signal's negative width will be narrower (about 20 $\mu\text{s}$ -40 $\mu\text{s}$ ). You can adjust filter parameter to accurately filter trigger signal.

### 8.2.11. Overlapping Exposure and Non-overlapping Exposure

There are two stages in image acquisition of the camera: exposure and readout. Once the camera is triggered, it begins to integrate and when the integration is over, the image data will be read out immediately.

The camera supports two exposure modes: overlapping exposure and non-overlapping exposure. The user cannot assign the overlapping exposure or non-overlapping exposure directly, it depends on the frequency of trigger signal and the exposure time. The two exposure mode are described as below.

- **Non-overlapping exposure**

In non-overlapping exposure mode, after the exposure and readout of the current frame are completed, then the next frame will expose and read out. As shown in the Figure 8-23, the N<sup>th</sup> frame is read out, after a period of time, the N+1<sup>th</sup> frame to be exposed.

The formula of non-overlapping exposure frame period:

$$\text{non-overlapping exposure frame period} > \text{exposure time} + \text{readout time}$$

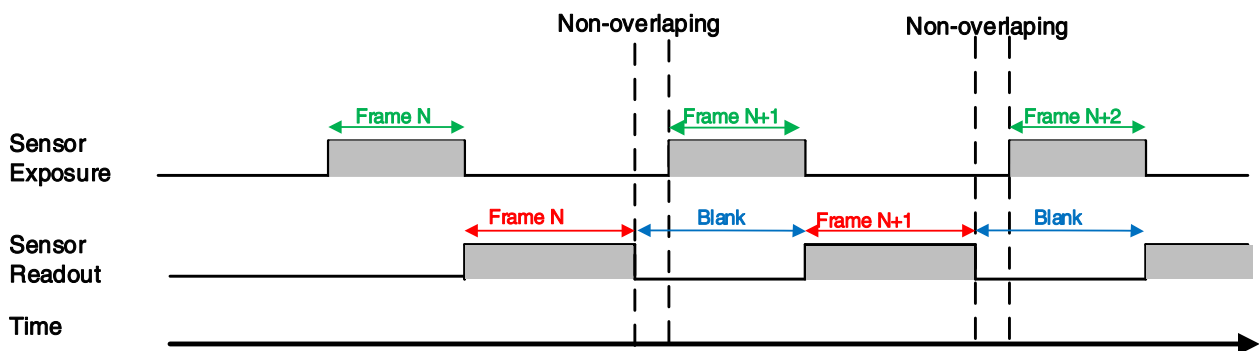

Figure 8-23 The exposure sequence diagram in non-overlapping exposure mode

● **Trigger acquisition mode**

If the interval between two triggers is greater than the sum of the exposure time and readout time, it will not occur overlapping exposure, as shown in Figure 8-24.

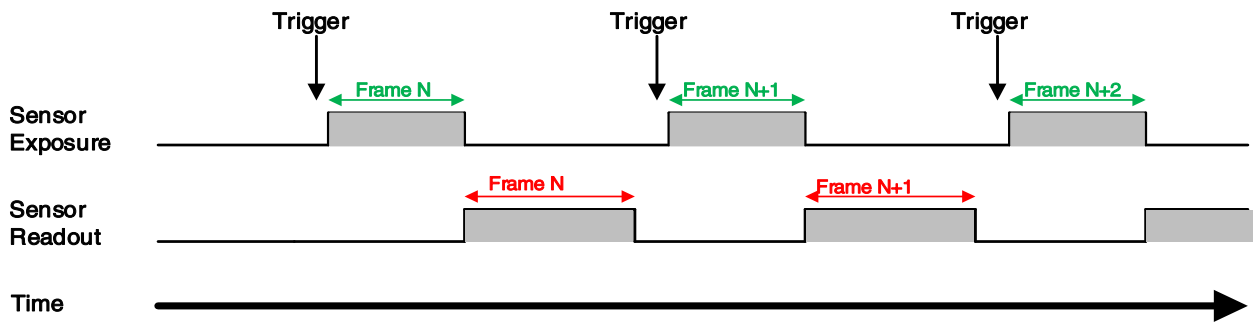

Figure 8-24 The trigger acquisition exposure sequence diagram in non-overlapping exposure mode

● **Overlapping exposure**

In overlapping exposure mode, the current frame image exposure process is overlapping with the readout of the previous frame. That is, when the previous frame is reading out, the next frame image has been started exposure. As shown in the Figure 8-25, when the N<sup>th</sup> frame image is reading out, the N+1<sup>th</sup> frame image has been started exposure.

The formula of overlapping exposure frame period:

$$\text{overlapping exposure frame period} \leq \text{exposure time} + \text{readout time}$$

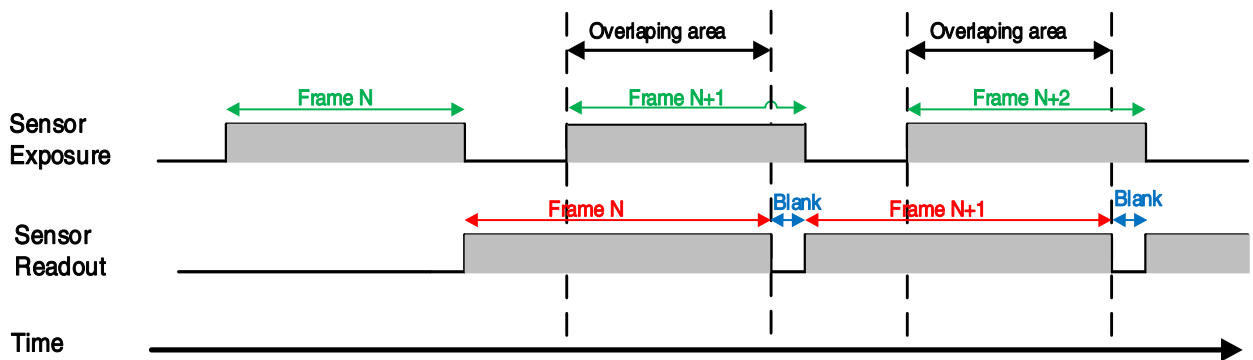

Figure 8-25 The exposure sequence diagram in overlapping exposure mode

● **Trigger mode OFF**

If the exposure time is greater than the frame blanking time, the exposure time and the readout time will be overlapped. As shown in the Figure 8-25.

● **Trigger\_mode ON**

When the interval between two triggers is less than the sum of exposure time and the readout time, it will occur overlapping exposure, as shown in Figure 8-26.

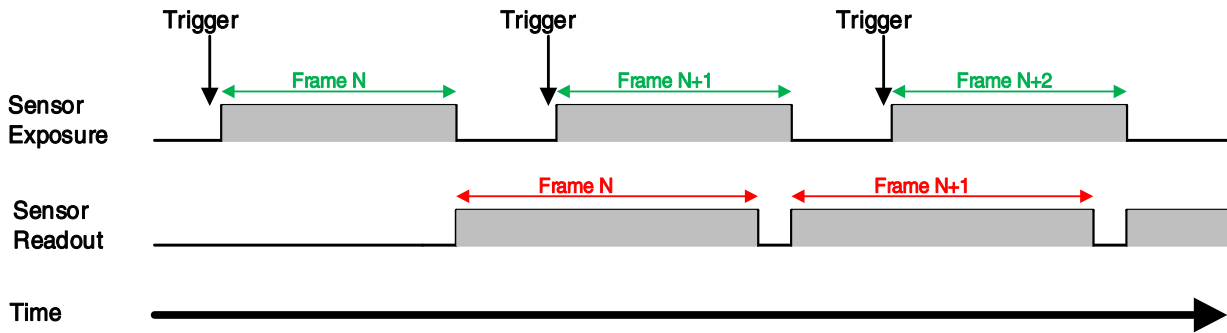

Figure 8-26 The trigger acquisition exposure sequence diagram in overlapping exposure mode

Compared with non-overlapping exposure mode, in overlapping exposure mode, the camera can obtain higher frame rate.

## 8.2.12. Set Exposure

### 8.2.12.1. Set Exposure Mode

Two Exposure Mode are available: Timed exposure mode and TriggerWidth exposure mode. Among them, the TriggerWidth exposure mode determines the exposure time when the camera is configured for hardware triggering. And the exposure time depends on the width of the trigger signal, which is triggered by the rising edge (falling edge) set by the Trigger Activation.

#### 1) Timed exposure mode

Timed exposure mode is available on all camera models. In this mode, the exposure time is determined by the camera's Exposure Time setting. If the camera is configured for software triggering, exposure starts when the software trigger signal is received and continues until the exposure time has expired.

If the camera is configured for hardware trigger:

- If rising edge triggering is enabled, exposure starts when the trigger signal rises and continues until the exposure time has expired, as shown in Figure 8-27

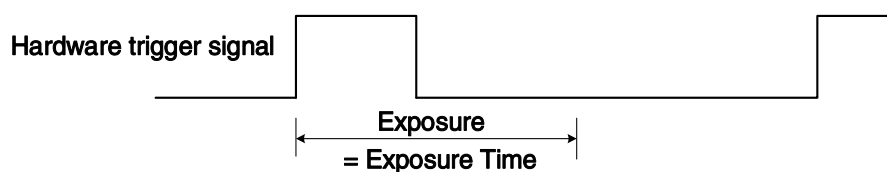

Figure 8-27 The sequence diagram in rising edge trigger of Timed exposure mode

- If falling edge triggering is enabled, exposure starts when the trigger signal falls and continue until the exposure time has expired, as shown in Figure 8-28

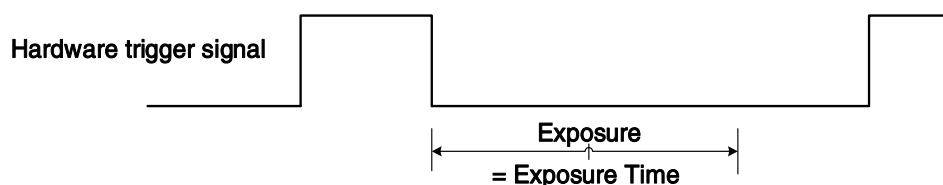

Figure 8-28 The sequence diagram in falling edge trigger of Timed exposure mode

Avoid overtriggering in Timed exposure mode. If the Timed exposure mode is enabled, do not attempt to send a new trigger signal while the previous exposure is still in progress. Otherwise, the trigger signal will be ignored, and a FrameStartOvertrigger event will be generated.

2) TriggerWidth exposure mode

In TriggerWidth exposure mode, the length of exposure is determined by the width of the hardware trigger signal. This function can meet the needs of users to change the exposure time of each frame of image.

- If rising edge triggering is enabled, exposure starts when the trigger signal rises and continue until the trigger signal falls, as shown in Figure 8-29

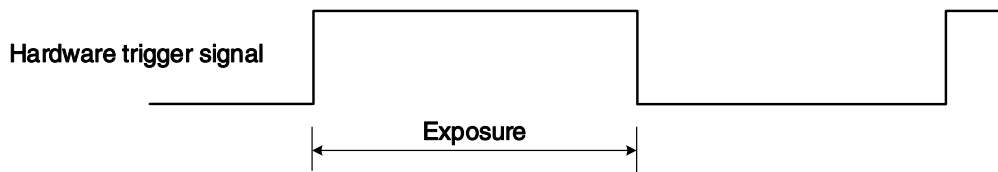

Figure 8-29 The sequence diagram in rising edge trigger of TriggerWidth exposure mode

- If falling edge triggering is enabled, exposure starts when the trigger signal falls and continue until the trigger signal rises, as shown in Figure 8-30

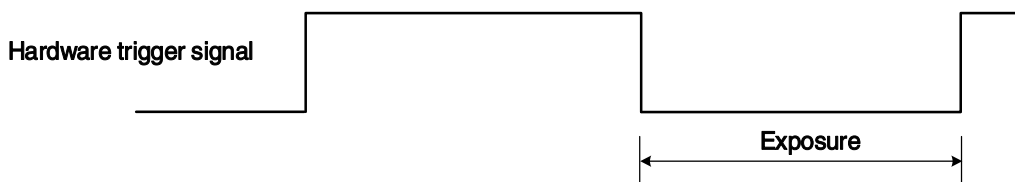

Figure 8-30 The sequence diagram in falling edge trigger of TriggerWidth exposure mode

Avoid overtriggering in TriggerWidth exposure mode. If the TriggerWidth exposure mode is enabled, do not send trigger signals at too high a rate. Otherwise, trigger signals will be ignored, and a FrameStartOvertrigger event will be generated.

The Exposure Overlap Time Max feature can optimize the acquisition of overlapping images. This parameter is especially useful if the user wants to maximize the camera's frame rate, i.e., if the user wants to trigger at the highest rate possible.

- **Prerequisites**

- Set the TriggerMode parameter to On.
- Set the TriggerSource parameter to one of the available hardware trigger source, e.g., Line0.
- Set the ExposureMode parameter to TriggerWidth exposure mode.

- **How it works**

The user can use overlapping image acquisition to increase the frame rate of the camera. With overlapping image acquisition, the exposure of a new image begins while the camera is still reading out the sensor data of the previous image.

In TriggerWidth exposure mode, the camera does not "know" how long the image will be exposed before the trigger period is complete. Therefore, the camera cannot fully optimize overlapping image acquisition. To avoid this problem, the user can enter a value for the ExposureOverlapTimeMax parameter, which represents the shortest exposure time the user intends to use (in  $\mu\text{s}$ ). This helps the camera optimize the overlapping image acquisition.

- **Set ExposureOverlapTimeMax**

To optimize the frame rate of the camera, the exposure mode should be set to TriggerWidth:

- Set the ExposureMode parameter to TriggerWidth.
- Enter a value for the ExposureOverlapTimeMax parameter, which represents the shortest exposure time the user intends to use (in  $\mu\text{s}$ ).

Example: Assume that the user wants to trigger the camera to apply exposure times in the range of 3000  $\mu\text{s}$  to 5500  $\mu\text{s}$ , the user needs to set the ExposureOverlapTimeMax parameter of the camera to 3000.

**i** The trigger signal width of the hardware triggering should not be shorter than the value of the entered ExposureOverlapTimeMax parameter.

### 8.2.12.2. Set Exposure Value

- **Global Shutter**

The implementation process of global shutter is as shown in Figure 8-31, all the lines of the sensor are exposed at the same time, and then the sensor will read out the image data one by one.

The advantage of the global shutter is that all the lines are exposed at the same time, and the images do not appear offset and distortion when capturing moving objects.

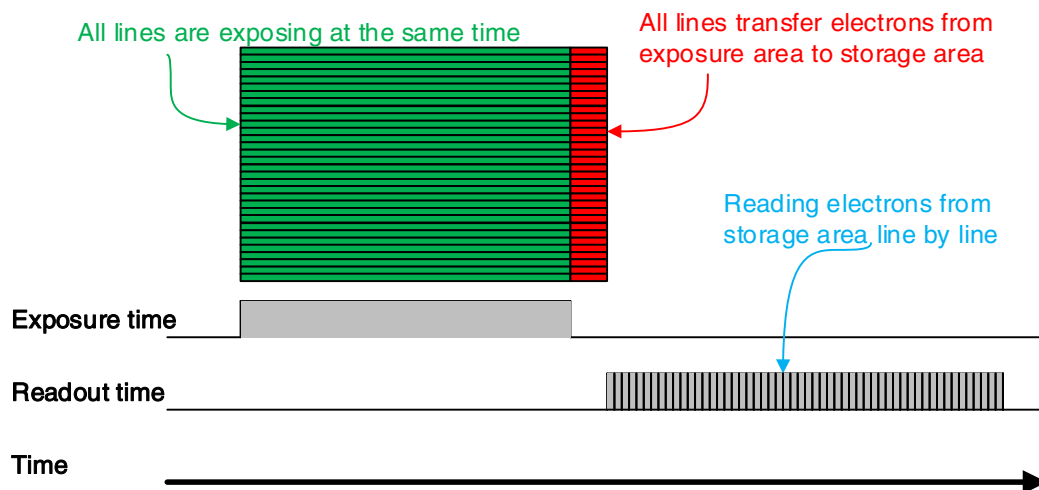

Figure 8-31 Global Shutter

- **Electronic Rolling Shutter**

The implementation process of electronic rolling shutter is as shown in Figure 8-32, different from the global shutter, electronic rolling shutter exposures from the first line, and starts the second line exposure

after a row period. And so on, after N-1 line, the N line starts exposing. When the first line exposure ends, it begins to read out the data, and it need a row period time to read out one line (including the line blanking time). When the first line reads out completely, the second line just begins to read out, and so on, when the N-1 line is read out, the N line begins to read out, until the whole image is read out completely.

The electronic rolling shutter has low price and high resolution, which is a good choice for some static image acquisition.

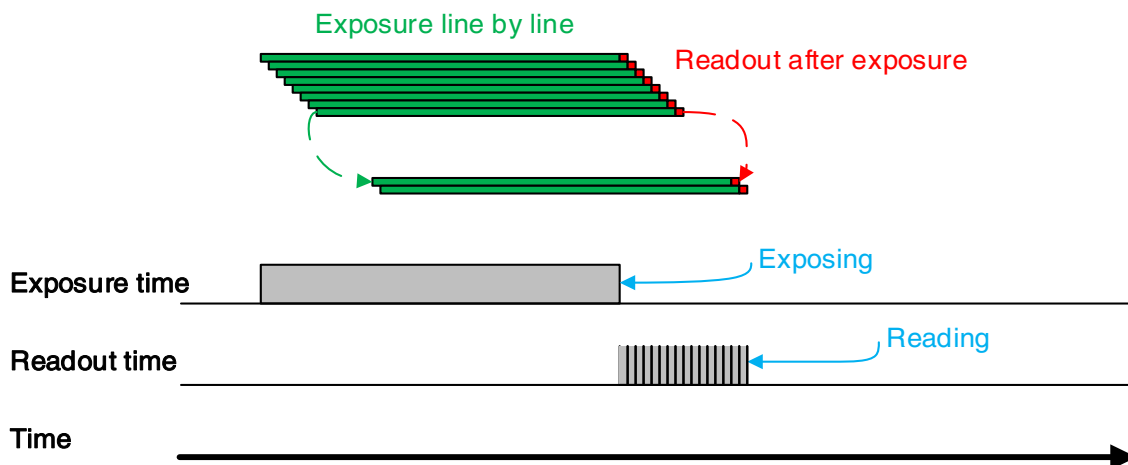

Figure 8-32 Electronic rolling shutter

● Global Reset Release Shutter

The implementation process of global reset rolling shutter is as shown in Figure 8-33. When using rolling shutter sensor taking photos of fast-moving objects, the upper and lower exposure start and end points of the same frame of image are different which will occur smear phenomenon. The Global Reset Release exposure method can effectively avoid smear, and it must be used with flash.

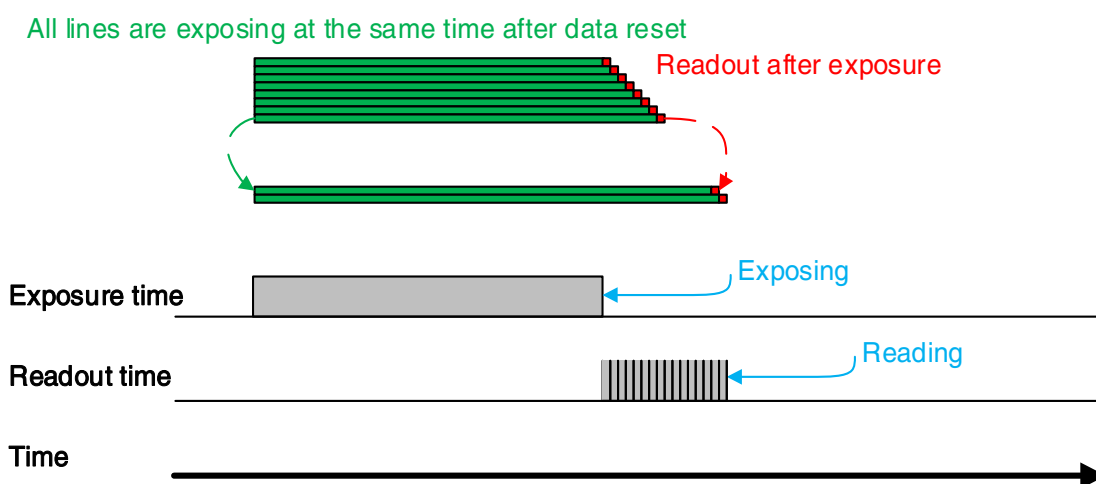

Figure 8-33 Global reset rolling shutter

All the lines of the electronic rolling shutter sensor are exposed at the same time in GRR mode, and end the exposure sequentially from top to bottom. The flash need turn on during the exposure interval, and turn off beyond the exposure interval to avoid the smear and ununiformed brightness of the image.

The camera support exposure delay in GRR mode, and there is a delay when the flash turn on, so the actual flash time is as follows:

$$T_{strobe} = T_{ahead} + T_{exp\_delay} + T_{exposure}$$

Set conditions:

- 1) Set the "SensorShutterMode" to "Global Reset"
- 2) External camera flash

Camera model that support Global Reset Release Shutter mode:

Model	$T_{ahead}$ (row period time)
VE2S-630-18GM/C-P	82

### 8.2.12.3. Exposure Time Mode

According to the length of the exposure time, two exposure time modes of the camera are available: Standard exposure time mode and UltraShort exposure time mode.

In Standard exposure time mode, three exposure time adjustment modes are available: manual adjustment, one-time automatic adjustment and continuous automatic adjustment. The standard exposure time mode is the default setting. For the manual adjustment, please refer to section 8.2.11. For the automatic adjustment and continuous automatic adjustment, please refer to section 8.3.4.3.

In UltraShort exposure time mode, the camera only supports manual adjustment of the exposure time. Since standard exposure time mode is the default setting, if you want to set the UltraShort exposure time mode, you first need to adjust the visibility level to guru and set the ExposureTimeMode to UltraShort under the acquisition control features window.



In UltraShort exposure time mode, the camera does not support automatic adjustment of the exposure time, only support manual adjustment of the exposure time.

### 8.2.12.4. Set Exposure Time

The camera supports setting the exposure time, step: 1 $\mu$ s.

The exposure precision of the camera is limited by the sensor, when the steps in the user's interface and the demo display as 1 $\mu$ s, actually the steps is one row period. When the value of the ExposureTime cannot be divisible by the row period, round up to an integer should be taken, such as the row period is 36 $\mu$ s, setting 80 $\mu$ s exposure time, and the actual exposure time is 108 $\mu$ s.

When the external light source is sunlight or direct current (DC), the camera has no special requirements for the exposure time. When the external light source is alternating current (AC), the exposure time must synchronize with the external light source (under 50Hz light source, the exposure time must be a multiple of 1/100s, under 60Hz light source, the exposure time must be a multiple of 1/120s), to ensure better image quality.

The camera supports Auto Exposure feature. If the Auto Exposure feature is enabled, the camera can adjust the exposure time automatically according to the environment brightness. See section 8.3.4 for more details.

### 8.2.13. Exposure Delay

The exposure delay function can effectively solve the strobe delay problem. Most strobes have a delay of at least tens of microseconds from trigger to light. When the camera is working in a small exposure mode, the fill light effect of the strobe will be affected. The exposure delay is achieved by the strobe signal and the delay of the actual exposure starting.

The unit of exposure delay is  $\mu\text{s}$ , the range is  $0 \sim 5000\mu\text{s}$ , and the minimum value is 0.

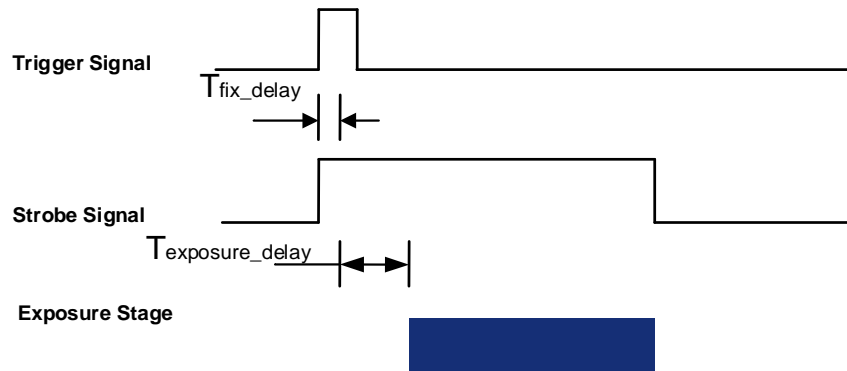

Figure 8-34 The exposure delay sequence diagram in overlapping exposure mode

When a trigger signal is received to the sensor to start exposure, there is a small delay, which is called the exposure delay and consists of five parts of time.

T1: The delay introduced by the hardware circuit when the external signal passes through the optocoupler or GPIO. The value is generally in the range of several to several tens of  $\mu\text{s}$ . The delay is mainly affected by the connection mode, driving intensity and temperature. When the external environment is constant, the delay is generally stable.

T2: Delay introduced by the trigger filter. For example, if the trigger filter time is set to  $50\mu\text{s}$ , T2 is  $50\mu\text{s}$ .

T3: Trigger delay (trigger\_delay), the camera supports trigger delay feature. If the trigger delay is set to  $200\mu\text{s}$ , T3 is  $200\mu\text{s}$ .

T4: Exposure delay (exposure\_delay), the exposure delay time mentioned above. If the exposure delay is set to  $200\mu\text{s}$ , T4 is  $200\mu\text{s}$ .

T5: The sensor timing sequence delay, the internal exposure of the sensor is aligned with the row timing sequence, so T5 has a maximum row cycle jitter. The value of each sensor is different.

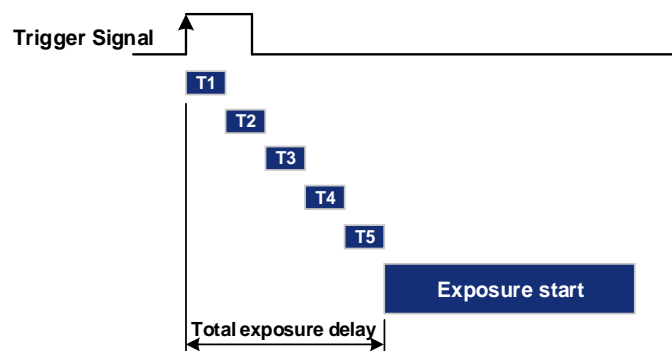

Figure 8-35 Exposure delay

The following table shows the total exposure delay time for each sensor.

T1 is calculated according to the typical delay (5μs) of Line0. If it is Line2, T1 can be ignored.

T2/3/4 is calculated as 0μs.

T5 is calculated according to the ROI settings and features of each sensor.

The exposure delay data for each model is as follows:

Model	Exposure delay (μs)
VE2S-042-121GM/C-P	Non-overlapping Exposure: Mono8/BayerRG8: 33.534, Mono12/BayerRG12: 62.068 Overlapping Exposure: Mono8/BayerRG8: 33.534~47.801, Mono12/BayerRG12: 62.068~90.602
VE2S-161-75GM/C-P	Non-overlapping Exposure: Mono8/BayerRG8: 28.55, Mono12/BayerRG12: 52.1 Overlapping Exposure: Mono8/BayerRG8: 28.55~40.325, Mono12/BayerRG12: 52.1~63.875
VE2S-303-37GM/C-P	Non-overlapping Exposure: Mono8/BayerRG8: 31.880, Mono12/BayerRG12: 58.760 Overlapping Exposure: Mono8/BayerRG8: 31.880~45.320, Mono12/BayerRG12: 58.760~85.640
VE2S-501-23GM/C-P	Non-overlapping Exposure: Mono8/BayerRG8: 31.880, Mono12/BayerRG12: 58.760 Overlapping Exposure: Mono8/BayerRG8: 31.880~45.320, Mono12/BayerRG12: 58.760~85.640
VE2S-630-18GM/C-P	2950.404

### 8.3. Basic Features

#### 8.3.1. Gain

The camera can adjust the analog gain, and the range of analog gain as shown in section 4 General Specifications. When the analog gain changes, the response curve of the camera changes, as shown in Figure 8-36. The horizontal axis represents the output signal of the sensor in the camera, and the vertical axis represents the gray value of the output image. When the amplitude of the sensor output signal remains constant, increasing the gain makes the response curve steeper, and that makes the image brighter. For every 6dB increases of the gain, the gray value of the image will double. For example, when the camera has a gain of 0dB, the image gray value is 126, and if the gain is increased to 6dB, the image gray will increase to 252. Thus, increasing gain can be used to increase image brightness. When the environment brightness and exposure time keep constant, another way to increase the image brightness is to change the camera's digital gain by modifying the lookup table.

Note that increasing the analog gain or digital gain will amplify the image noise.

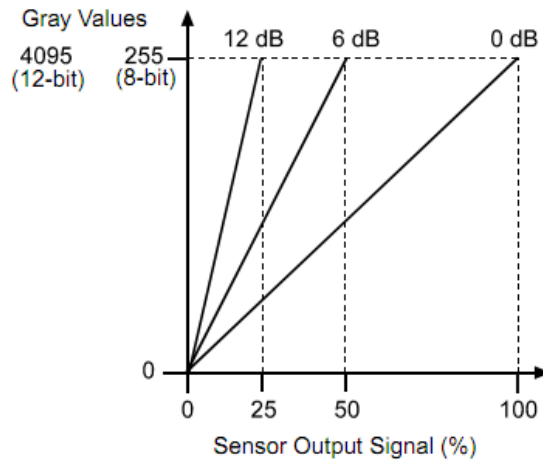

Figure 8-36 The camera's response curve

### 8.3.2. Pixel Format

By setting the pixel format, the user can select the format of output image. The available pixel formats depend on the camera model and whether the camera is monochrome or color.

The image data starts from the upper left corner, and each pixel is output brightness value of each pixel line from left to right and from top to bottom.

- **Mono8**

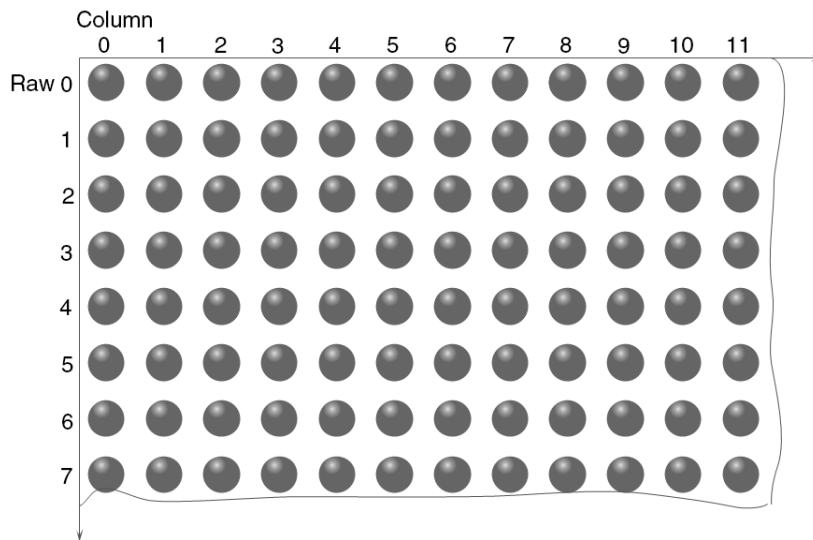

Figure 8-37 Mono8 pixel format

When the pixel format is set to Mono8, the brightness value of each pixel is 8 bits. The format in the memory is as follows:

Y00	Y01	Y02	Y03	Y04	.....
Y10	Y11	Y12	Y13	Y14	.....
.....					

Among them Y00, Y01, Y02 ... are the gray value of each pixel that starts from the first row of the image. Then the gray value of the second row pixels of the images is Y10, Y11, and Y12...

● **Mono10/Mono12**

When the pixel format is set to mono10 or Mono12, each pixel is 16 bits. When Mono10 is selected, the effective data is only 10 bits, the six unused most significant bits are filled with zero. When Mono12 is selected, the effective data is only 12 bits, the 4 of the MSB 16 bits data are set to zero. Note that the brightness value of each pixel contains two bytes, arranged in little-endian mode. The format is as follows:

Y00	Y01	Y02	Y03	Y04	.....
Y10	Y11	Y12	Y13	Y14	.....
.....					

Among them Y00, Y01, Y02...are the gray value of each pixel that start with the first row of the image. The first byte of each pixel is low 8 bits of brightness, and the second byte of each pixel is high 8 bits of brightness.

● **BayerRG8**

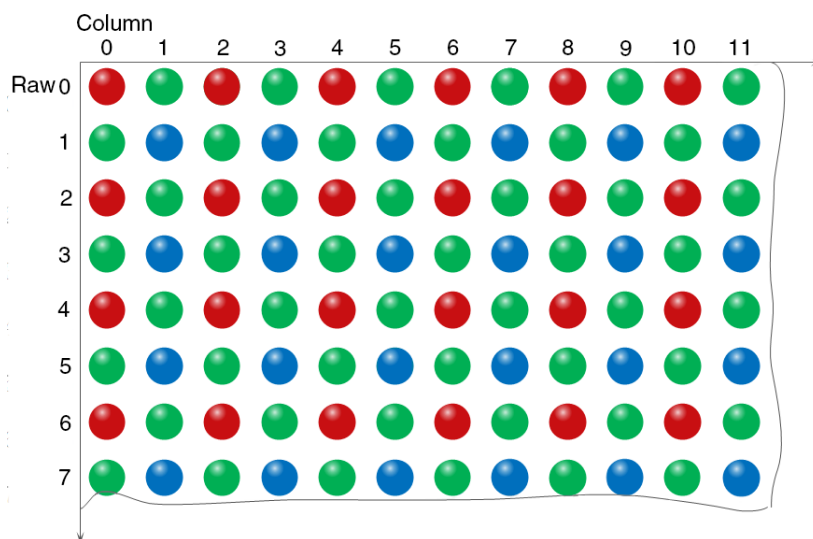

Figure 8-38 BayerRG8 pixel format

When the pixel format is set to BayerRG8, the value of each pixel in the output image of the camera is 8 bits. According to the location difference, the three components of red, green and blue are respectively represented. The format in the memory is as follows:

R00	G01	R02	G03	R04	.....
G10	B11	G12	B13	G14	.....
.....					

Where R00 is the first pixel value of the first row (for the red component), G01 represents the second pixel value (for the green component), and so on, so that the first row pixel values are arranged. G10 is the first pixel value of the second row (for the green component), the B11 is the second pixel value (for the blue component), and so on, and the second row of pixel values are arranged.

● BayerRG10/BayerRG12

When the pixel format is set to BayerRG10 or BayerRG12, the value of each pixel in the output image of the camera is 16 bits. According to the location difference, the three components of red, green and blue are respectively represented. The format in the memory is as follows:

R00	G01	R02	G03	R04	.....
G10	B11	G12	B13	G14	.....
.....					

Each pixel is the same as BayerRG8, the difference is that each pixel is made up of two bytes, the first byte is the low 8 bits of the pixel value, and the second byte is the high 8 bits of the pixel value.

● BayerGR8

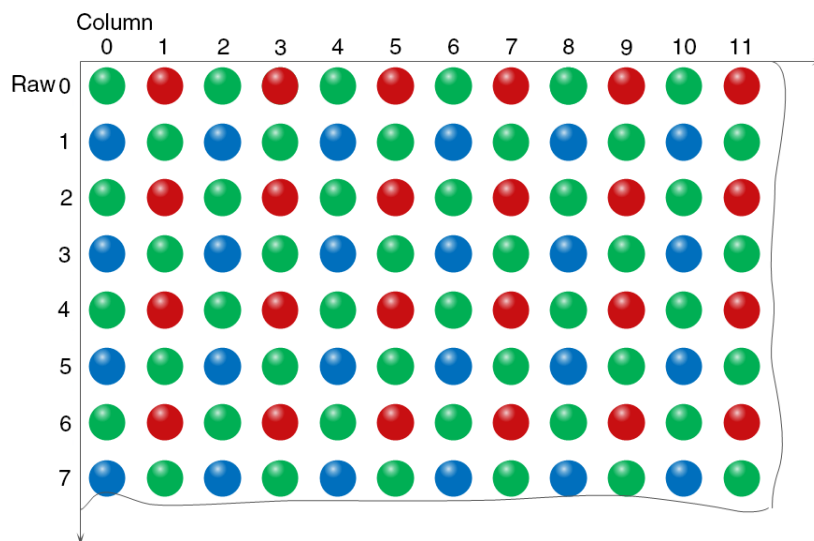

Figure 8-39 BayerGR8 pixel format

When the pixel format is set to BayerGR8, the value of each pixel in the output image of the camera is 8 bits. According to the location difference, the three components of red, green and blue are respectively represented. The format in the memory is as follows:

G00	R01	G02	R03	G04	.....
B10	G11	B12	G13	B14	.....
.....					

Where G00 is the first pixel value of the first row (for the green component), R01 represents the second pixel value (for the red component), and so on, so that the first row pixel values are arranged. B10 is the first pixel value of the second row (for the blue component), the G11 is the second pixel value (for the green component), and so on, and the second row of pixel values are arranged.

● BayerGR10/BayerGR12

When the pixel format is set to BayerGR10 or BayerGR12, the value of each pixel in the output image of the camera is 16 bits. According to the location difference, the three components of red, green and blue are respectively represented. The format in the memory is as follows:

G00	R01	G02	R03	G04	.....
B10	G11	B12	G13	B14	.....
.....					

Each pixel is the same as BayerRG8, the difference is that each pixel is made up of two bytes, the first byte is the low 8 bits of the pixel value, and the second byte is the high 8 bits of the pixel value.

● BayerGB8

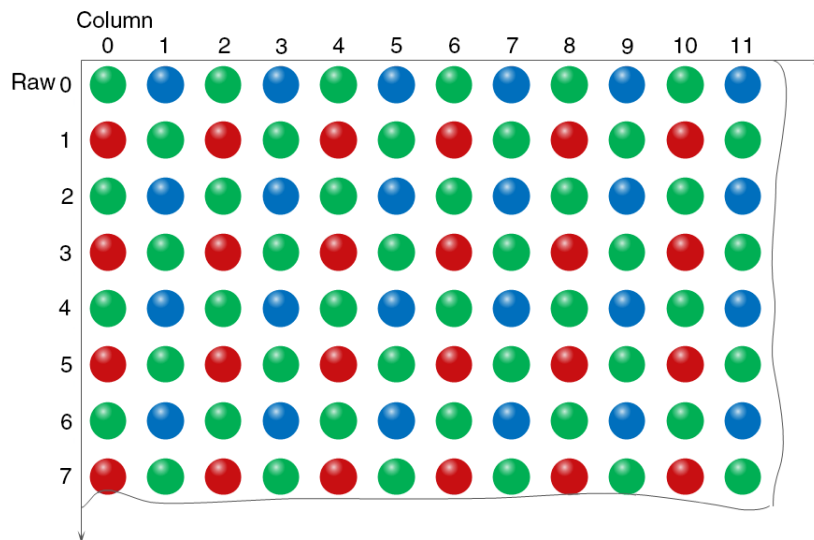

Figure 8-40 BayerGB8 pixel format

When the pixel format is set to BayerRG8, the value of each pixel in the output image of the camera is 8 bits. According to the location difference, the three components of red, green and blue are respectively represented. The format in the memory is as follows:

G00	B01	G02	B03	G04	.....
R10	G11	R12	G13	R14	.....
.....					

Where G00 is the first pixel value of the first row (for the green component), B01 represents the second pixel value (for the blue component), and so on, so that the first row pixel values are arranged. R10 is the first pixel value of the second row (for the red component), the G11 is the second pixel value (for the green component), and so on, and the second row of pixel values are arranged.

● BayerGB10/BayerGB12

When the pixel format is set to BayerGB10 or BayerGB12, the value of each pixel in the output image of the camera is 16 bits. According to the location difference, the three components of red, green and blue are respectively represented. The format in the memory is as follows:

G00	B01	G02	B03	G04	.....
R10	G11	R12	G13	R14	.....
.....					

Each pixel is the same as BayerGB8, the difference is that each pixel is made up of two bytes, the first byte is the low 8 bits of the pixel value, and the second byte is the high 8 bits of the pixel value.

8.3.3. ROI

By setting the ROI of the image, the camera can transmit the specific region of the image, and the output region's parameters include OffsetX, OffsetY, width and height of the output image. The camera only reads the image data from the sensor's designated region to the memory, and transfer it to the host, and the other regions' image of the sensor will be discarded.

By default, the image ROI of the camera is the full resolution region of the sensor. By changing the OffsetX, OffsetY, width and height, the location and size of the image ROI can be changed. The OffsetX refers to the starting column of the ROI, and the OffsetY refers to the starting row of the ROI.

The coordinates of the ROI of the image are defined the 0<sup>th</sup> line and 0<sup>th</sup> columns as the origin of the upper left corner of the sensor. As shown in the figure, the OffsetX of the ROI is 4, the OffsetY is 4, the height is 8 and the width is 12.

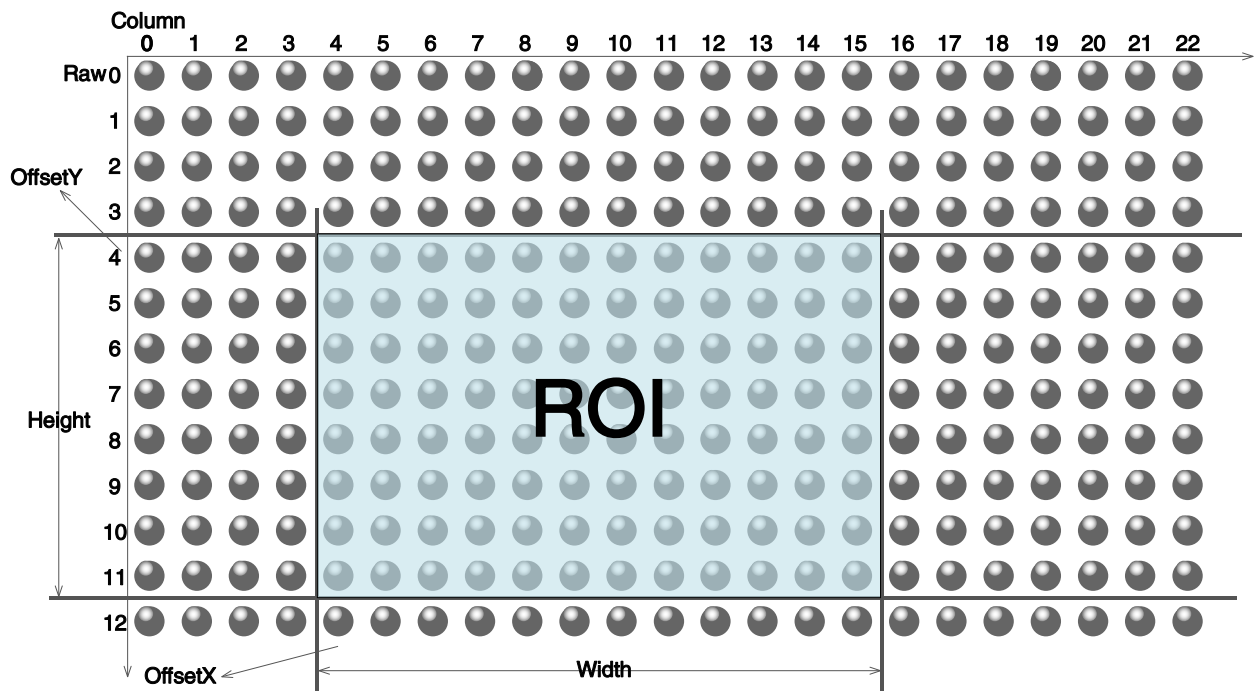

Figure 8-41 Mono8

When reducing the height of the ROI, the maximum frame rate of the camera will be raised. Please refer to section 1) for specific effects on the acquisition frame rate.

### 8.3.4. Auto Exposure / Auto Gain

#### 8.3.4.1. ROI Setting of Auto Exposure / Auto Gain

For Auto Exposure and Auto Gain, you can specify a portion of the sensor array and only the pixel data from the specified portion will be used for auto function control.

AAROI is defined by the following way:

AAROIOffsetX: The offset of the X axis direction.

AAROIOffsetY: The offset of the Y axis direction.

AAROIWidth: The width of ROI.

AAROIHeight: The height of ROI.

Offset is the offset value that relative to the upper left corner of the image. The step of AAROIOffsetX and AAROIWidth is 4. The step of AAROIOffsetY and AAROIHeight is 2. The setting of the AAROI depends on the size of the current image and cannot exceed the range of the current image. That is to say, assuming the Width and Height are parameters for users captured image, then the AAROI setting need to meet the condition 1:

$$\text{AAROIWidth} + \text{AAROIOffsetX} \leq \text{Width}$$

$$\text{AAROIHeight} + \text{AAROIOffsetY} \leq \text{Height}$$

If condition 1 is not met, the user cannot set the ROI.

The default value of ROI is the entire image, you can set the ROI according to your need. Where the minimum value of AAROIWidth can be set to 16, and the maximum value is equal to the current image width. The minimum value of AAROIHeight can be set to 16, and the maximum value is equal to the current image height, they are all need to meet the condition1.

For example: the current image width is 1024, the height is 1000, and then the ROI setting is:

$$\text{AAROIOffsetX} = 100$$

$$\text{AAROIOffsetY} = 50$$

$$\text{AAROIWidth} = 640$$

$$\text{AAROIHeight} = 480$$

The relative position of the ROI and the image is shown in Figure 8-42.

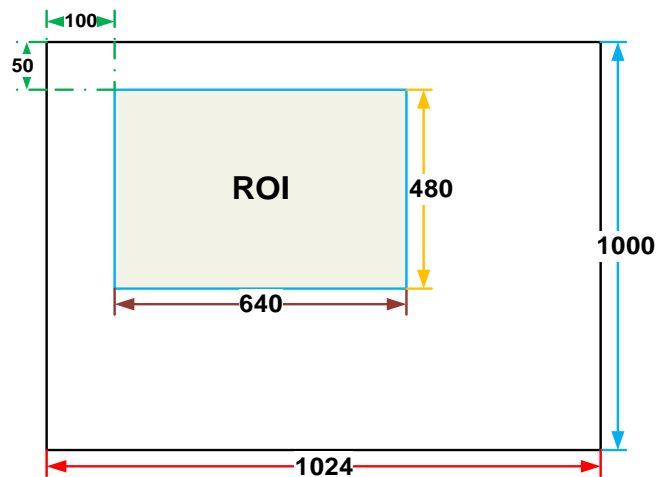

Figure 8-42 An example for the relative position between the ROI and the current image

#### 8.3.4.2. Auto Gain

The auto gain can adjust the camera's gain automatically, so that the average gray value in AAROI is achieved to the expected gray value. The auto gain can be controlled by "Once" and "Continuous" mode.

When using the "Once" mode, the camera adjusts the image data in the AAROI to the expected gray value once, then the camera will turn off the auto gain feature. When using the "Continuous" mode, the camera will continuous adjust the gain value according to the data of the AAROI, so that the data in the AAROI is kept near to the expected gray level.

The expected gray value is set by the user, and it is related to the data bit depth. For 8bit pixel data, the expected gray value range is 0-255, for 10bit pixel data, the expected gray value range is 0-1023, and for 12bit pixel data, the expected gray value range is 0-4095.

The camera adjusts the gain value within the range [minimum gain value, maximum gain value] which is set by the user.

The auto gain feature can be used with the auto exposure at the same time, when target grey is changed from dark to bright, the auto exposure adjust is prior to auto gain adjust. Vice versa, when target grey is changed from bright to dark, the auto gain adjust is prior to auto exposure adjust.

#### 8.3.4.3. Auto Exposure

The auto exposure can adjust the camera's exposure time automatically, so that the average gray value in AAROI can achieve to the expected gray value. The auto exposure can be controlled by "Once" and "Continuous" mode.

When using the "Once" mode, the camera adjusts the image data in the AAROI to the expected gray value once, then the camera will close the auto exposure feature. When using the "Continuous" mode, the camera will continuously adjusting the exposure time according to the data of the AAROI, so that the data in the ROI is kept near to the expected gray level.

The expected gray value is set by the user and it is related to the data bit depth. For 8bit pixel data, the expected gray value range is 0-255, and for 12bit pixel data, the expected gray value range is 0-4095.

The camera adjusts the exposure time in the range [minimum exposure time, maximum exposure time] which is set by the user.

The auto exposure feature can be used with the auto gain at the same time, when target grey is changed from dark to bright, the auto exposure adjust is prior to auto gain adjust. Vice versa, when target grey is changed from bright to dark, the auto gain adjust is prior to auto exposure adjust.

### 8.3.5. Test Pattern

The camera supports three test images: gray gradient test image, static diagonal gray gradient test image, and moving diagonal gray gradient test image. When the camera captures in RAW12 mode, the gray value of test image is: the pixel gray value in RAW8 mode multiplies by 16, as the output of pixel gray value in RAW12 mode. The following three test images are illustrated in the RAW8 mode.

- **GrayFrameRampMoving**

In the gray gradient test image, all the pixels' gray values are the same in the frame. In the adjacent frame, the gray value of the next frame increases by 1 compared to the previous frame, until to 255, and then the next frame gray value returns to 0, and so on. A printscreen of a single frame is shown in Figure 8-43:



Figure 8-43 Gray gradient test image

- **SlantLineMoving**

In the moving diagonal gray gradient test image, the first pixel value of adjacent row in each frame increases by 1, until the last row. When the pixel gray value increases to 255, the next pixel gray value returns to 0. The first pixel gray value of adjacent column increases by 1, until the last column. When the pixel gray value increases to 255, the next pixel gray value returns to 0.

In the moving diagonal gray gradient test image, in the adjacent frame, the first pixel gray value of the next frame increases by 1 compared to the previous frame. So, in the dynamic image, the image is scrolling to the left. A printscreen of the moving diagonal gray gradient test image is shown in Figure 8-44:

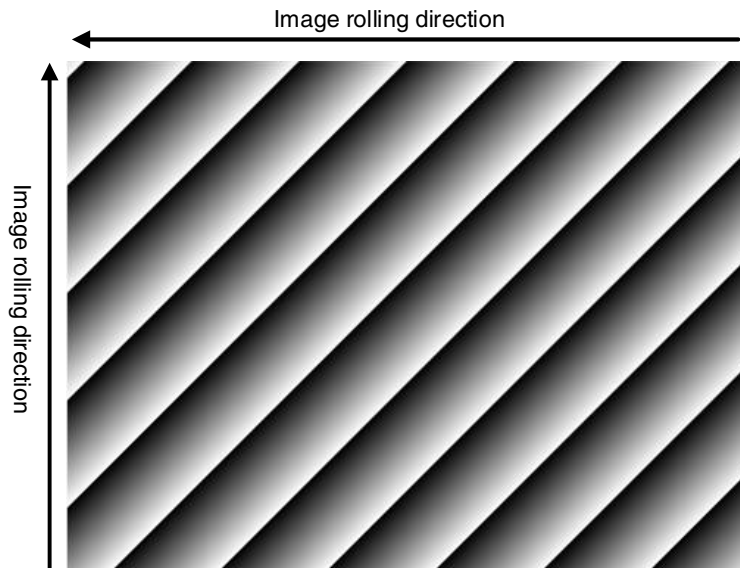

Figure 8-44 Moving diagonal gray gradient test image

- **SlantLine**

In the static diagonal gray gradient test image, the first pixel gray value is 0, the first pixel gray value of adjacent row increases by 1, until the last row. When the pixel gray value increases to 255, the next pixel gray value returns to 0. The first pixel gray value of adjacent column increases by 1, until the last column. When the pixel gray value increases to 255, the next pixel gray value returns to 0.

Compared to the moving diagonal gray gradient test image, in the adjacent image of the static diagonal gray gradient test image, the gray value in the same position remains unchanged. A print screen of the static diagonal gray gradient test image is shown in Figure 8-45.



Figure 8-45 Static diagonal gray gradient test image

### 8.3.6. User Set Control

By setting various parameters of the camera, the camera can perform the best performance in different environments. There are two ways to set parameters: one is to modify the parameters manually, and the other is to load parameter set. In order to save the specific parameters of the users, avoiding to set the parameters every time when you open the camera, the camera provides a function to save the parameter set, which can easily save the parameters that the user use, including the control parameters that the camera needed. Three types of configuration parameters are available: the currently effective configuration parameters, the vendor default configuration parameters (Default), and the user configuration parameters (UserSet).

Three operations can be performed on the configuration parameters, including save parameters (UserSetSave), load parameters (UserSetLoad), and set the startup parameter set (UserSetDefault). The UserSetSave is to save the effective configuration parameters to the user configuration parameter set which is set by the user. The UserSetLoad is to load the vendor default configuration parameters (Default) or the user configuration parameters (UserSet) to the current effective configuration parameters. The UserSetDefault is refer to the user can specify a set of parameters which to be loaded into the effective configuration parameters automatically when the camera is reset or powered on. And the camera can work under this set of parameters. This set of parameters can be vendor default configuration parameters or user configuration parameters.

### 1) The type of configuration parameters

The type of configuration parameters includes: the current effective configuration parameters, vendor default configuration parameters, user configuration parameters.

The current effective configuration parameters: Refers to the current control parameters used by the camera. Using API function or Demo program to modify the current control parameters of the camera is to modify the effective configuration parameters. The effective parameters are stored in volatile memory of the camera, so when the camera is reset or powered on again, the effective configuration parameters will be lost.

The vendor default configuration parameters (Default): Before the camera leaves the factory, the camera manufacturer will test the camera to assess the camera's performance and optimize the configuration parameters of the camera. The manufacturer's default configuration parameters are the camera configuration parameters optimized by the manufacture in a particular environment, these parameters are stored in the non-volatile memory of the camera, so when the camera is reset or powered on again, the effective configuration parameters will not be lost, and these parameters cannot be modified.

The user configuration parameters (UserSet): The effective parameters are stored in volatile memory of the camera, so when the camera is reset or powered on again, the effective configuration parameters will be lost. You can store the effective configuration parameters to the user configuration parameters, the user configuration parameters are stored in the non-volatile memory of the camera, so when the camera is reset or powered on again, the user configuration parameters will not be lost. The camera can store a set of user configuration parameters.

### 2) The operation of configuration parameters

The operations for configuration parameters include the following three types: save parameters, load parameters and set the UserSetDefault.

**Save parameters (UserSetSave):** Save the current effective configuration parameters to the user configuration parameters. The storage steps are as follows:

- 1) Modify the camera's configuration parameters, until the camera runs to the user's requirements.
- 2) Use UserSetSelector to select UserSet0. Execute UserSetSave command.

The camera's configuration parameters which are saved in the user parameter set include:

- Gain

- ExposureTime
- TransferControlMode
- PixelFormat
- OffsetX, OffsetY, ImageWidth, ImageHeight
- GevSCPSPacketSize, GevSCPD
- EventNotification
- TriggerMode, TriggerSource, TriggerPolarity, TriggerDelay
- TriggerFilterRaisingEdge, TriggerFilterFallingEdge
- LineMode, LineInverter, LineSource, UserOutputValue
- FrameBufferOverwriteActive
- ChunkModeActive
- TestPattern
- ExpectedGrayValue
- ExposureAuto, AutoExposureTimeMax, AutoExposureTimeMin
- GainAuto, AutoGainMax, AutoGainMin
- AAROIOffsetX, AAROIOffsetY, AAROIWidth, AAROIHeight
- BalanceWhiteAuto, AWBLampHouse
- AWBROIOffsetX, AWBROIOffsetY, AWBROIWidth, AWBROIHeight
- BalanceRatio(R/G/B)
- LUT, Gamma, Color Correction
- Binning, Decimation
- AcquisitionMode
- Reverse X and Reverse Y
- Sharpness
- ExposureDelay

**Load parameters (UserSetLoad):** Load the vendor default configuration parameters or the user configuration parameters into the effective configuration parameters. After this operation is performed, the effective configuration parameters will be covered by the loaded parameters which are selected by the user, and the new effective configuration parameters are generated. The operation steps are as follows:

- 1) Use UserSetSelector to select Default or UserSet0.
- 2) Execute UserSetLoad command to load the User Set specified by UserSetSelector to the device and makes it active.

**Change startup parameter set (UserSetDefault):** The user can use UserSetDefault to select Default or UserSet0 as the UserSetDefault. When the camera is reset or powered on again, the parameters in the UserSetDefault will be loaded into the effective configuration parameters.

### 8.3.7. Device User ID

The camera provides programmable device user ID function, the user can set a unique identification for the camera, and can open and control the camera by the unique identification.

The user-defined name is a string which maximum length is 16 bytes, the user can set it by the following ways:

- 1) Set by the **IP Configurator**, for details please see section "GigE IP Configurator":

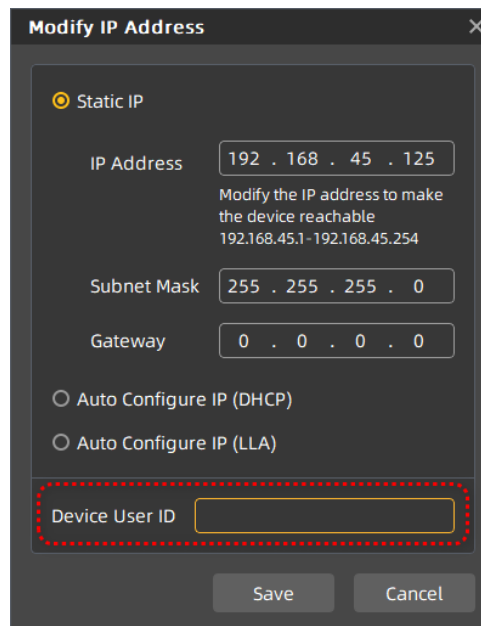

Figure 8-46 IP Configurator

- 2) Set by calling the software interface, for details please see the Programmer's Guide.



When using multi-cameras at the same time, it is necessary to ensure the uniqueness of the user-defined name of each camera, otherwise, an exception will occur when the camera is opened.

### 8.3.8. Timestamp

The timestamp feature counts the number of ticks generated by the camera's internal device clock. As soon as the camera is powered on, it starts generating and counting clock ticks. The counter is reset to 0 whenever the camera is powered off and on again. Some of the camera's features use timestamp values, such as event, and timestamps can be used to test the time spent on some of the camera's operations.

Timestamp clock frequency: The frequency of timestamp counter is obtained by reading the camera's "timestamp tick frequency". The unit is 8ns.

Timestamp latch: Latch the current timestamp value. The timestamp value needs to be read through the "timestamp latch value".

Timestamp reset: Reset the timestamp counter and recount from 0.

Timestamp latch reset: First latch the current timestamp value and then reset the timestamp counter.

Timestamp latched value: Save the value of the latched timestamp, and the specific time can be calculated based on the timestamp clock frequency.

### 8.3.9. Binning

The feature of Binning is to combine multiple pixels adjacent to each other in the sensor into a single value, and process the average value of multiple pixels or sum the multiple pixel values, which may increase the signal-to-noise ratio or the camera's response to light.

- **How Binning Works**

On color cameras, the camera combines (sums or averages) the pixel values of adjacent pixels of the same color:

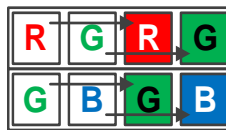

Figure 8-47 Horizontal color Binning by 2



Figure 8-48 Vertical color Binning by 2

When the horizontal Binning factor and the vertical Binning factor are both set to 2, the camera combines the adjacent 4 sub-pixels of the same color according to the corresponding positions, and outputs the combined pixel values as one sub-pixel.



Figure 8-49 Horizontal and vertical color Binning by 2x2

On monochrome cameras, the camera combines (sums or averages) the pixel values of directly adjacent pixels:

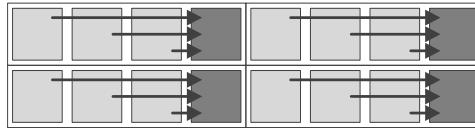

Figure 8-50 Horizontal mono Binning by 4

### ● Binning Factors

Two types of Binning are available: horizontal Binning and vertical Binning. You can set the Binning factor in one or two directions.

Horizontal Binning is the processing of pixels in adjacent rows.

Vertical Binning is the processing of pixels in adjacent columns.

Binning factor 1: Disable Binning.

Binning factor 2, 4: Indicate the number of rows or columns to be processed.

For example, the horizontal Binning factor 2 indicates that the Binning is enabled in the horizontal direction, and the pixels of two adjacent rows are processed.

### ● Binning Modes

The Binning mode defines how pixels are combined when Binning is enabled. Two types of the Binning mode are available: Sum and Average.

**Sum:** The values of the affected pixels are summed and then output as one pixel. This improves the signal-to-noise ratio, but also increases the camera's response to light.

**Average:** The values of the affected pixels are averaged. This greatly improves the signal-to-noise ratio without affecting the camera's response to light.

### ● Considerations When Using Binning

#### 1) Effect on ROI settings

When Binning is used, the value of the current ROI of the image, the maximum ROI of the image, the auto function ROI, and the auto white balance ROI will change. The changed value is the original value (the value before the setting) divided by the Binning factor.

For example, assume that you are using a camera with a 1200 x 960 sensor. Horizontal Binning by 2 and vertical Binning by 2 are enabled. In this case, the maximum ROI width is 600 and the maximum ROI height is 480.

#### 2) Increased response to light

Using Binning with the Binning mode set to **Sum** can significantly increase the camera's response to light. When pixel values are summed, the acquired images may look overexposed. If this is the case, you can reduce the lens aperture, the intensity of your illumination, the camera's exposure time setting, or the camera's gain setting.

3) Possible image distortion

Objects will only appear undistorted in the image if the numbers of binned rows and columns are equal. With all other combinations, objects will appear distorted. For example, if you combine vertical Binning by 2 with horizontal Binning by 4, the target objects will appear squashed.

4) Mutually exclusive with Decimation

Binning and Decimation cannot be used simultaneously in the same direction. When the horizontal Binning value is set to a value other than 1, the horizontal Decimation feature cannot be used. When the vertical Binning value is set to a value other than 1, the vertical Decimation feature cannot be used.

8.3.10. Decimation

The Decimation can reduce the number of sensor pixel columns or rows that are transmitted by the camera, reducing the amount of data that needs to be transferred and reducing bandwidth usage.

● How Vertical Decimation Works

On mono cameras, if you specify a vertical Decimation factor of  $n$ , the camera transmits only every  $n^{\text{th}}$  row. For example, when you specify a vertical Decimation factor of 2, the camera skips row 1, transmits row 2, skips row 3, and so on.

On color cameras, if you specify a vertical Decimation factor of  $n$ , the camera transmits only every  $n^{\text{th}}$  pair of rows. For example, when you specify a vertical Decimation factor of 2, the camera skips rows 1 and 2, transmits rows 3 and 4, skips rows 5 and 6, and so on.

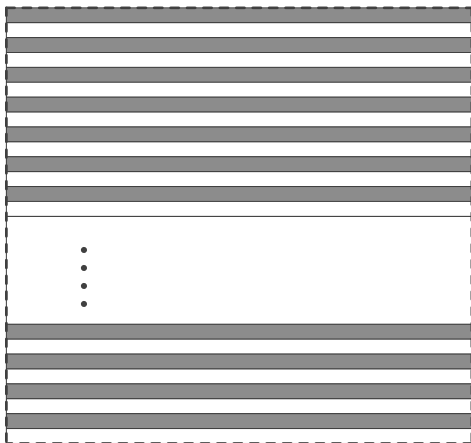

Figure 8-51 Mono camera vertical Decimation

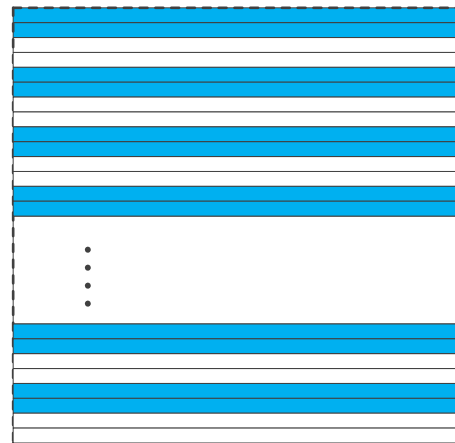

Figure 8-52 Color camera vertical Decimation

As a result, the image height is reduced. For example, enabling vertical Decimation by 2 halves the image height. The camera automatically adjusts the image ROI settings.

Vertical Decimation significantly increases the camera’s frame rate.

● How Horizontal Decimation Works

On mono cameras, if you specify a horizontal Decimation factor of  $n$ , the camera transmits only every  $n^{\text{th}}$  column. For example, if specify set a horizontal Decimation factor of 2, the camera skips column 1, transmits column 2, skips column 3, and so on.

On color cameras, if you specify a horizontal Decimation factor of  $n$ , the camera transmits only every  $n^{\text{th}}$  pair of columns. For example, if you specify a horizontal Decimation factor of 2, the camera skips columns 1 and 2, transmits columns 3 and 4, skips columns 5 and 6, and so on.

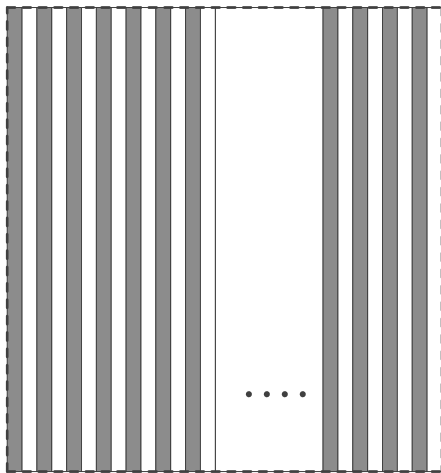

Figure 8-53 Mono camera horizontal Decimation

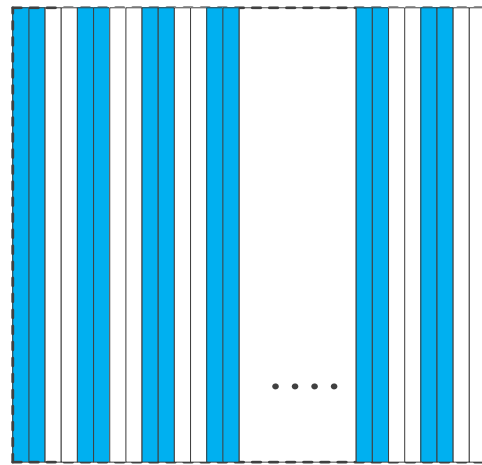

Figure 8-54 Color camera horizontal Decimation

As a result, the image width is reduced. For example, enabling horizontal Decimation by 2 halves the image width. The camera automatically adjusts the image ROI settings.

Horizontal Decimation does not (or only to a very small extent) increase the camera's frame rate.

### ● Configuring Decimation

To configure vertical Decimation, enter a value for the DecimationVertical parameter. To configure horizontal Decimation, enter a value for the DecimationHorizontal parameter.

The value of the parameters defines the Decimation factor. Depending on your camera model, the following values are available:

- 1: Disable Decimation.
- 2: Enable Decimation.

### ● Considerations When Using Decimation

#### 1) Effect on ROI settings

When you are using Decimation, the settings for your image ROI refer to the resulting number of rows and columns. Taking VE2S-501-23GM as an example, the camera's default resolution is 2448×2048. When horizontal Decimation by 2 and vertical Decimation by 2 are enabled, the maximum ROI width would be 1244 and the maximum ROI height would be 1024.

#### 2) Reduced resolution

Using Decimation effectively reduces the resolution of the camera's imaging sensor. Taking VE2S-501-23GM as an example, the camera's default resolution is 2448×2048. When horizontal Decimation by 2 and vertical Decimation by 2 are enabled, the effective resolution of the sensor is reduced to 1224×1024.

3) Possible image distortion

The displayed image will not be distorted if the vertical and horizontal Decimation factors are equal. When only horizontal Decimation or vertical Decimation is used, the displayed image will be reduced in width or height.

4) Mutually exclusive with Binning

Decimation and Binning cannot be used simultaneously in the same direction. When the horizontal Decimation value is set to a value other than 1, the horizontal Binning feature cannot be used. When the vertical Decimation value is set to a value other than 1, the vertical Binning feature cannot be used.

8.3.11. Reverse X and Reverse Y

The Reverse X and Reverse Y features can mirror acquired images horizontally, vertically, or both.

- Enabling Reverse X

To enable Reverse X, set the **ReverseX** parameter to **true**. The camera mirrors the image horizontally.



Figure 8-55 The original image



Figure 8-56 Reverse X enabled

- Enabling Reverse Y

To enable Reverse Y, set the **ReverseY** parameter to **true**. The camera mirrors the image vertically.



Figure 8-57 The original image



Figure 8-58 Reverse Y enabled

- Enabling Reverse X and Y

To enable Reverse X and Y, set the **ReverseX** and **ReverseY** parameters to **true**. The camera mirrors the image horizontally and vertically.



Figure 8-59 The original image

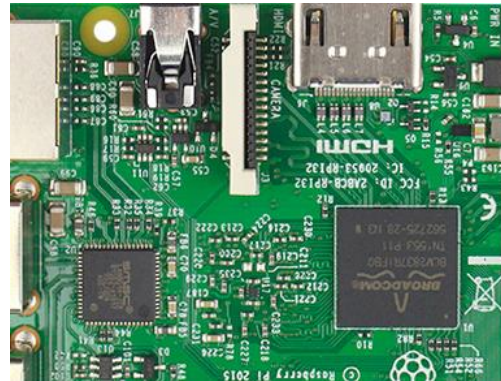

Figure 8-60 Reverse X and Y enabled

- Using Image ROI with Reverse X or Reverse Y

If you have specified an image ROI while using Reverse X or Reverse Y, you must bear in mind that the position of the ROI relative to the sensor remains the same. Therefore, the camera acquires different portions of the image depending on whether the Reverse X or the Reverse Y feature are enabled:



Figure 8-61 The original image



Figure 8-62 Reverse X enabled

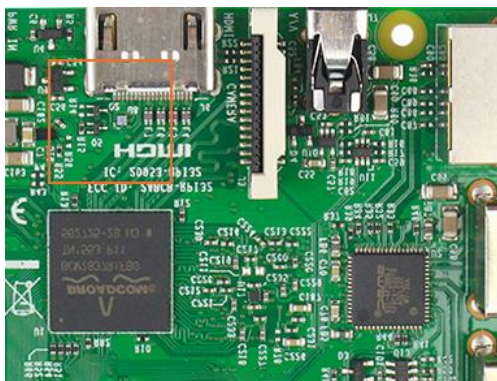

Figure 8-63 Reverse Y enabled

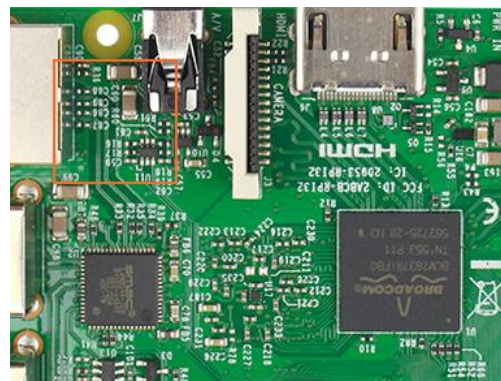

Figure 8-64 Reverse X and Y enabled

- **Pixel Format Alignment**

The alignment of the Bayer format does not change when the camera is using the reverse feature.

### 8.3.12. Digital Shift

The Digital Shift can multiply the pixel values by  $2^n$  of the images.

This increases the brightness of the image. If your camera doesn't support the digital shift feature, you can use the Gain feature to achieve a similar effect.

- **How Digital Shift Works**

Configuring a digital shift factor of  $n$  results in a logical left shift by  $n$  on all pixel values. This has the effect of multiplying all pixel values by  $2^n$ .

If the resulting pixel value is greater than the maximum value possible for the current pixel format (e.g., 255 for an 8-bit pixel format, 1023 for a 10-bit pixel format, and 4095 for a 12-bit pixel format), the value is set to the maximum value.

- **Configuring Digital Shift**

To configure the digital shift factor, enter the expected value for the **DigitalShift** parameter.

By default, the parameter is set to 0, i.e., digital shift is disabled. When the **DigitalShift** parameter is set to 1, the camera will shift the pixel value to the left by 1 bit. When the **DigitalShift** parameter is set to 2, the camera will shift the pixel value to the left by 2 bits.

- **Considerations When Using Digital Shift**

Example 1: Digital Shift by 1, 12-bit Image Data

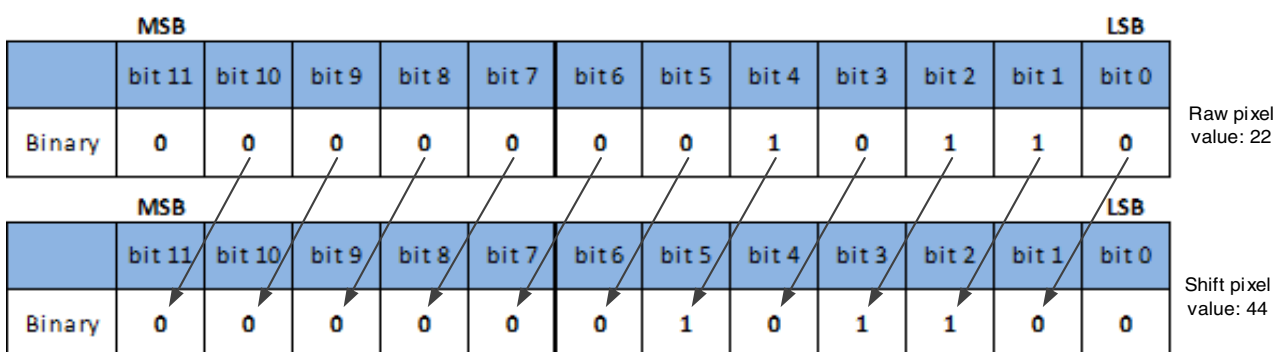

The least significant bit in each 12-bit image data is set to 0.

Example 2: Digital Shift by 2, 8-bit Image Data

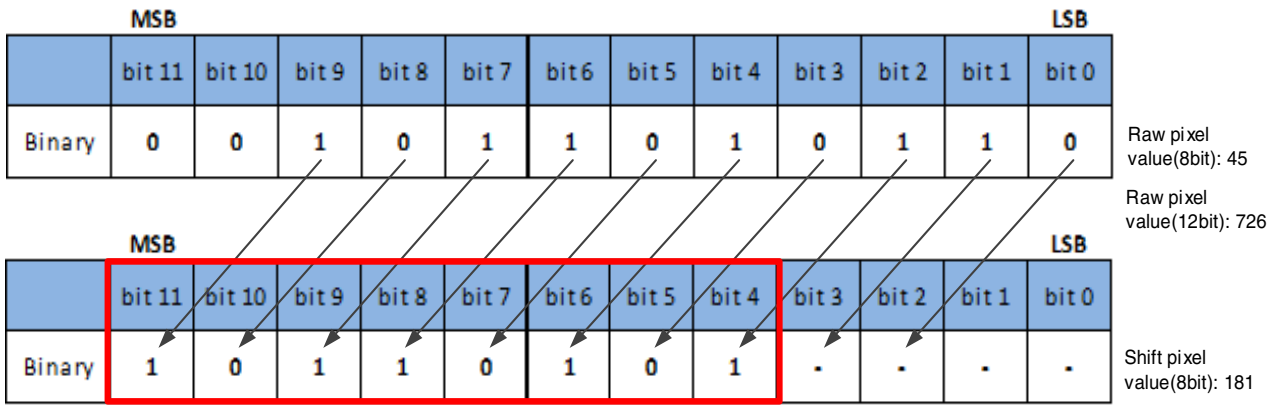

Assume that your camera has a maximum pixel bit depth of 12-bit, but is currently using an 8-bit pixel format. In this case, the camera first performs the digital shift calculation on the 12-bit image data. Then, the camera transmits the 8 most significant bits.

**Example 3: Digital Shift by 1, 12-bit Image Data, High Value**

Assume that your camera is using a 12-bit pixel format. Also assume that one of your original pixel values is 2839.

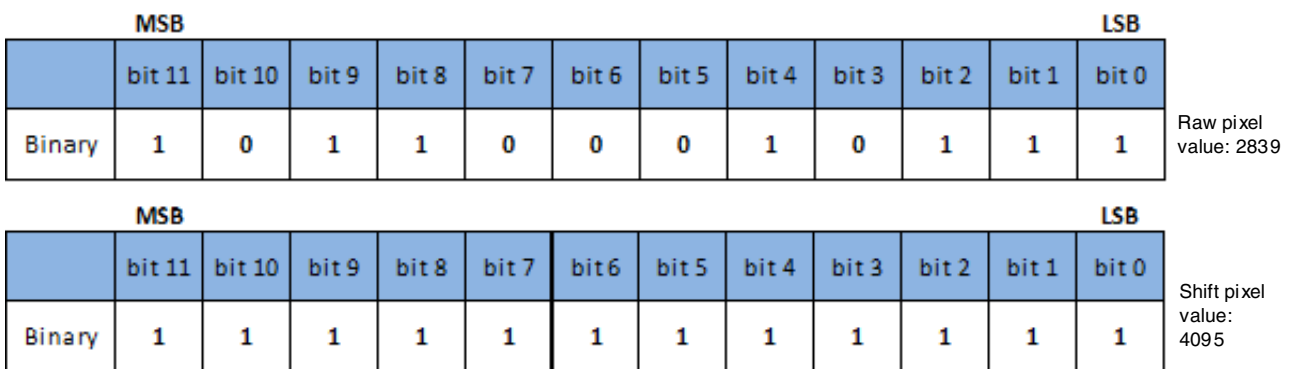

If you apply digital shift by 1 to this pixel value, the resulting value is greater than the maximum possible value for 12-bit pixel formats. In this case, the value is set to the maximum value, i.e., all bits are set to 1.

**8.3.13. Acquisition Status**

The Acquisition Status feature can determine whether the camera is waiting for trigger signals. This is useful if you want to optimize triggered image acquisition and avoid over triggering.

**To determine if the camera is currently waiting for trigger signals:**

- a) Set the **AcquisitionStatusSelector** parameter to the expected trigger type. Two trigger types are available: **FrameTriggerWait** and **AcquisitionTriggerWait**. For example, if you want to determine if the camera is waiting for **FrameStartTrigger** signals, set the **AcquisitionStatusSelector** to **FrameTriggerWait**. If you want to determine if the camera is waiting for **FrameBurstStartTrigger** signals, set the **AcquisitionStatusSelector** to **AcquisitionTriggerWait**.
- b) If the **AcquisitionStatus** parameter is **true**, the camera is waiting for a trigger signal of the trigger type selected. If the **AcquisitionStatus** parameter is **false**, the camera is busy.

### 8.3.14. Black Level and Auto Black Level

#### 8.3.14.1. Black Level

The Black Level can change the overall brightness of an image by changing the gray values of the pixels by a specified amount. Currently, the application range of the black level value can only be selected as all pixels, and pixel selection is not supported.

The lower the black level, the darker the corresponding image, the higher the black level, the brighter the corresponding image.

#### 8.3.14.2. Auto Black Level

The dark current is greatly affected by the ambient temperature and individual differences are greater for high resolution camera models. The auto black level function ensures that the average gray value of the 12bit image is 0 when the camera is in the dark field. The default mode is "Continuous" and the black level automatically adjusting. If it is "Once" mode, the auto black level mode will automatically change to OFF after once adjustment. If it is "Off" mode, the auto black level is disabled.

### 8.3.15. Remove Parameter Limits

The range of camera parameters is usually limited, and these factory limits are designed to ensure the best camera performance and high image quality. However, for certain use cases, you may want to specify parameter values outside of the factory limits. You can use the remove parameter limits feature to expand the parameter range. The features of the extended range supported by different cameras may be different and the range may be different, as shown in Table 8-1.

Model	Features	Set the switch to off	Set the switch to on
VE2S-042-121GM/C-P VE2S-161-75GM/C-P	Exposure	20~1000000	20~15000000
	Auto Exposure	20~1000000	20~15000000
	Gain	0~24	0~48
	Auto Gain	0~24	0~48
	Black Level	0~255	0~255
	Sharpness	0~3	0~63
	White Balance component factor	0~15.998	0~31.998
	Auto White Balance	1~15.998	1~31.998
VE2S-303-37GM/C-P	Exposure	20~1000000	20~15000000
	Auto Exposure	20~1000000	20~15000000
	Gain	0~24	0~48
	Auto Gain	0~24	0~48
	Black Level	0~4084	0~4084
	White Balance component factor	0~15.998	0~31.998
	Auto White Balance	1~15.998	1~31.998

VE2S-501-23GM/C-P	Exposure	20~1000000	20~15000000
	Auto Exposure	20~1000000	20~15000000
	Gain	0~24	0~48
	Auto Gain	0~24	0~48
	Black Level	0~511	0~511
	Sharpness	0~3	0~63
	White Balance component factor	0~15.998	0~31.998
	Auto White Balance	1~15.998	1~31.998
VE2S-630-18GM/C-P	Exposure	19~1000000	19~15000000
	Auto Exposure	19~1000000	19~15000000
	Gain	0~24	0~27
	Auto Gain	0~24	0~27
	Black Level	0~4095	0~4095
	Sharpness	0~3	0~63
	White Balance component factor	0~15.998	0~31.998
	Auto White Balance	1~15.998	1~31.998

Table 8-1 Parameter range of features supported before and after Remove Parameter Limits

### 8.3.16. User Data Area

The user data area is a FLASH data area reserved for the user, and the user can use the area to save algorithm factors, parameter configurations, etc.

The user data area is 16K bytes and is divided into 4 data segments, each of which is 4K bytes. The user can access the user data area through the API interface. The data is saved to the camera flash area immediately after being written, and the data will not disappear after the camera is powered off.

### 8.3.17. Timer

The camera only supports one timer (Timer1), which can be started by a specified event or signal (only ExposureStart signal is supported). The timer can configure a timer output signal that goes high on a specific event or signal and goes low after a specific duration. After a trigger source event that starts the TimerTrigger Source occurs, it starts to delay for a specified time. When the delay has expired, the timer output signal is enabled and stays high for the duration. When the duration has expired, the timer output signal is disabled and goes low, and the timer is cleared at the same time. A schematic diagram of the timer working process is as follows:

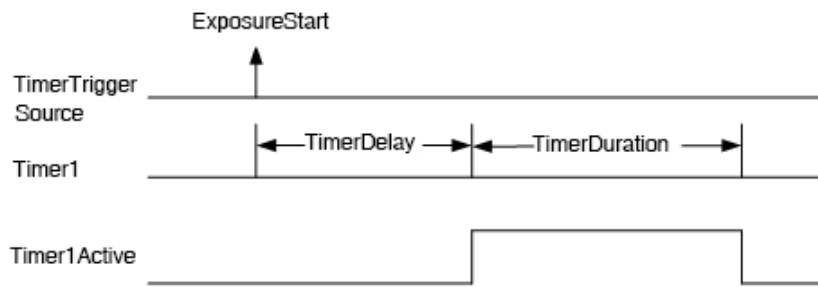

Figure 8-65 The schematic diagram of Timer1Active

The timer configuration process is as follows:

1. Set TimerSelector, currently only Timer1 supported.
2. Set LineSelector.
3. Set the LineSource to Timer1Active.
4. Set TimerTriggerSource, currently only ExposureStart supported.
5. Set TimerDelay, the range of TimerDelay is [0, 16777215], the unit is  $\mu\text{s}$ .
6. Set TimerDuration, the range of TimerDuration is [0, 16777215], the unit is  $\mu\text{s}$ .
  - 1) From the start of the timer to the full output of Timer1Active, this process will not be interrupted by the ExposureStart signal, and Timer1Active must be completely output to start timing according to the next ExposureStart signal. As shown in the Figure 8-66, the red ExposureStart signals are ignored.

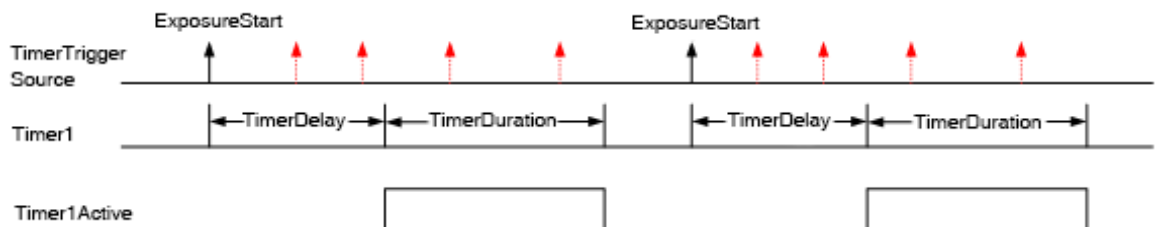

Figure 8-66 The relationship between Timer1Active and the ExposureStart signal

- 2) After the acquisition is stopped, the timer is immediately cleared and the Timer1Active signal goes low immediately.

### 8.3.18. Counter

The camera only supports one counter (Counter1), which can count the number of FrameTrigger, AcquisitionTrigger and FrameStart signals received by the camera. The counter starts counting from 0. You can select one of the above three signals to count by CounterEventSource. The FrameTrigger and AcquisitionTrigger signals of the counter statistics refer to the signals that have been triggered for filtering without a trigger delay.

If CounterValue is enabled, the statistical data can be inserted into the frame information and output with the image.

The counter can be reset by an external signal. The reset source is selected by CounterResetSource. Currently, the CounterResetSource option supports Off, SoftWare, Line0, and Line2. Among them, Off means no reset, SoftWare means software reset, Line0 or Line2 means reset through IO interface input signal. The polarity of the reset signal only supports RisingEdge, which means reset the Counter on the rising edge of the reset signal.

Counter configuration:

1. Set CounterSelector, currently only Counter1 supported.
2. Set CounterEventSource, the values that can be set are FrameStart, FrameTrigger, AcquisitionTrigger.
3. Set CounterResetSource, the values that can be set are Off, SoftWare, Line0, Line2.
4. Set CounterResetActivation, currently only RisingEdge supported.



- 1) After the acquisition is stopped, the Counter continues to work, will not be cleared, and it will be cleared when the camera is powered off.
- 2) CounterReset is used to software reset the counter.

## 8.4. Image Processing

### 8.4.1. Light Source Preset

Some cameras support light source preset function, and provides Off mode, Custom mode, and four specified common color temperature light source modes. The camera provides the corresponding white balance coefficient and color transformation coefficient in the four specified color temperature light source modes.

- **Off Mode**

The camera does not perform white balance and color conversion processing on the image by default.

- **Custom Mode**

The camera does not perform white balance and color conversion processing on the image by default.

Users can perform automatic white balance, or manually input white balance coefficients, and it supports color conversion enable control and manually input color conversion coefficients.

- **Daylight-6500K**

When the user selects **Daylight-6500K** in the light source preset, the camera will perform white balance processing on the image by default. If the external environment light source used is D65 light source, the image will not produce color deviation.

Even if the current light source is selected as the light source preset, users can also manually adjust the white balance coefficient.

Users can turn on the color conversion enable switch and calibrate according to the color conversion coefficient of the **Daylight-6500K** light source (manual input of color correction coefficients is not supported).

The option operation of **Daylight5000K**, **CoolWhiteFluorescence**, **INCA** is the same as **Daylight-6500K**.

## 8.4.2. Auto White Balance

### 8.4.2.1. Auto White Balance ROI

Auto White Balance feature use the image data from AWBROI to calculate the white balance ratio, and then balance ratio is used to adjust the components of the image.

ROI is defined in the following way:

AWBROIOffsetX: The offset of the X axis direction.

AWBROIOffsetY: The offset of the Y axis direction.

AWBROIWidth: The width of ROI.

AWBROIHeight: The height of ROI.

Offset is the offset value that relative to the upper left corner of the image. Where the step length of X axis direction offset and width is 4, the step length of Y axis direction offset and height is 2. The ROI setting depends on the current image and cannot exceed the current image range. Assuming the current image width is Width, the image height is Height, then the ROI setting need to meet the following condition 2:

$$\text{AWBROIWidth} + \text{AWBROIOffsetX} \leq \text{Width}$$

$$\text{AWBROIHeight} + \text{AWBROIOffsetY} \leq \text{Height}$$

If condition 2 is not met, the user cannot set the ROI.

The default value of ROI is the entire image, you can set the "white dot" area (ROI) according to your need. Where the minimum value of AWBROIWidth can be set is 16, the maximum value is equal to the current image width. The minimum value of AWBROIHeight can be set is 16, the maximum value is equal to the current image height, they are all need to meet the condition 2.

Assuming the current image width is 1024, the height is 1000, and then the "white dot" area ROI setting is:

$$\text{AWBROIOffsetX} = 100$$

$$\text{AWBROIOffsetY} = 50$$

$$\text{AWBROIWidth} = 640$$

$$\text{AWBROIHeight} = 480$$

The relative position of the ROI and the image is shown in Figure 8-67.

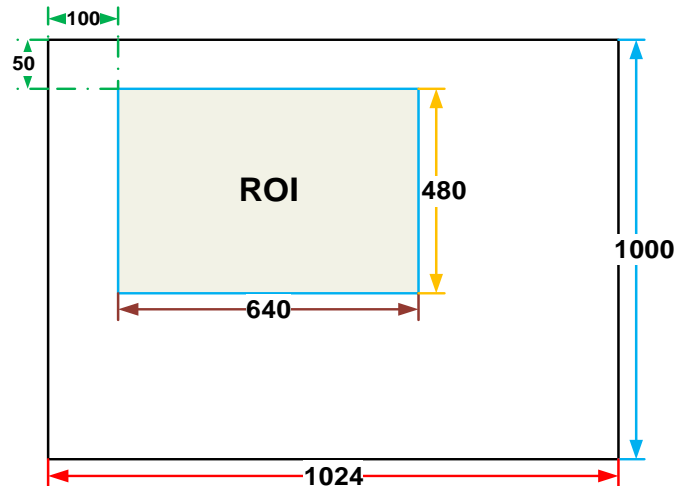

Figure 8-67 An example for the relative position between the ROI and the current image

#### 8.4.2.2. Auto White Balance Adjustment

The auto white balance can be set to "Once" or "Continuous" mode. When using the "Once" mode, the camera just adjusts the white balance ratio only once, when using the "Continuous" mode, the camera continuously adjusts the white balance ratio based on the data in AWBROI.

The auto white balance feature can also select the color temperature. When the color temperature of the selection is "Adaptive", the data in ROI always adjusting the red, green and blue to the same. When selecting the specific color temperature, the camera adjusts the factor according to the light source, so that the hue of the ROI is the same as the hue of the light source. That is: high temperature is cold, low color temperature is warm.

The auto white balance feature is only available on color sensors.

#### 8.4.3. Color Transformation Control

The Color Transformation is used to correct the color information delivered by the sensor, improve the color reproduction of the camera, and make the image closer to the human visual perception.



Figure 8-68 Color template

The user can use a color template containing 24 colors and shoot this color template with a camera, the RGB value of each color may be different from the standard RGB value of the standard color template, the vendor can use the software or hardware to convert the RGB value that is read to the standard RGB value. Because the color space is continuous, all the other RGB values that are read can be converted to the standard RGB values by using the mapping table created by the 24 colors.

### 1) Prerequisites

For the color transformation to work properly, the white balance must first be configured appropriately.

### 2) Configuring color transformation

#### a) Camera which not support light source preset function

There are two modes for configuring color transformation: default mode (RGBtoRGB), user-defined mode (User).

**RGBtoRGB:** Default color transformation parameters provided to the camera when it leaves the factory.

**User:**

- Set the **ColorTransformationValueSelector** parameter to the expected position in the matrix, e.g., Gain00.
- Enter the expected value for the **ColorTransformationValue** parameter to adjust the value at the selected position. The parameter's value range is -4.0 to +4.0.

**Color conversion:** It enabled when set to **true**.

#### b) Camera which support light source preset function

There are only default mode (RGBtoRGB) for configuring color transformation.

**Custom:**

- Set the **ColorTransformationValueSelector** parameter to the expected position in the matrix, e.g., Gain00.
- Enter the expected value for the **ColorTransformationValue** parameter to adjust the value at the selected position. The parameter's value range is -4.0 to +4.0.

**Color conversion:** It enabled when set to **true**.

In User/Custom mode, the user can input the color transformation value according to the actual situation to achieve the color transformation effect.

### 3) How it works

The color transformation feature uses a transformation matrix to deliver modified red, green, and blue pixel data for each pixel.

The transformation is performed by premultiplying a 3 x 1 matrix containing R, G, and B pixel values by a 3 x 3 matrix containing the color transformation values:

$$\begin{bmatrix} \text{Gain00} & \text{Gain01} & \text{Gain02} \\ \text{Gain10} & \text{Gain11} & \text{Gain12} \\ \text{Gain20} & \text{Gain21} & \text{Gain22} \end{bmatrix} \begin{bmatrix} R \\ G \\ B \end{bmatrix} = \begin{bmatrix} R' \\ G' \\ B' \end{bmatrix}$$

4) Effect images



Figure 8-69 Before color transformation



Figure 8-70 After color transformation

8.4.4. Saturation

Some cameras support saturation function. Saturation function can changes the colorfulness (intensity) of the colors to achieve the goal image effect.

1) Prerequisites

If the **SaturationEnable** parameter is available, it must be set to **On**.

2) Configuring saturation

Enter the expected value for the Saturation parameter and the range is 0 to 128. By default, the parameter is set to 64 (no saturation perform)

3) How it works

The saturation adjustment is performed by a  $3 \times 3$  matrix. When the saturation intensity is modified, the saturation can be changed by modifying the adjustment matrix A.

$$\begin{bmatrix} R_{out} \\ G_{out} \\ B_{out} \end{bmatrix} = \begin{bmatrix} RR & GR & BR \\ RG & GG & BG \\ RB & GB & BB \end{bmatrix} \begin{bmatrix} R_{in} \\ G_{in} \\ B_{in} \end{bmatrix} + \begin{bmatrix} R_{offset} \\ G_{offset} \\ B_{offset} \end{bmatrix} \quad A = \begin{bmatrix} RR & GR & BR \\ RG & GG & BG \\ RB & GB & BB \end{bmatrix}$$

Saturation adjustment and color correction adjustment both adopt the form of a matrix, so the saturation is adjusted at the same time after color correction is enabled.

4) Effect images



Figure 8-71 Before saturation



Figure 8-72 After saturation

### 8.4.5. Gamma

The Gamma can optimize the brightness of acquired images for display on a monitor.

#### 1) Prerequisites

If the **GammaEnable** parameter is available, it must be set to **true**.

#### 2) How it works

The camera applies a Gamma correction value ( $\gamma$ ) to the brightness value of each pixel according to the following formula (red pixel value  $R$  of a color camera shown as an example):

$$R_{\text{corrected}} = \left( \frac{R_{\text{uncorrected}}}{R_{\text{max}}} \right)^{\gamma} \times R_{\text{max}}$$

The maximum pixel value ( $R_{\text{max}}$ ) equals, e.g., 255 for 8-bit pixel formats, 1023 for 10-bit pixel formats or 4095 for 12-bit pixel formats.

#### 3) Enabling Gamma correction

To enable Gamma correction, use the **GammaValue** parameter. The **GammaValue** parameter's range is 0 to 4.00.

- a) Gamma = 1.0: the overall brightness remains unchanged.
- b) Gamma < 1.0: the overall brightness increases.
- c) Gamma > 1.0: the overall brightness decreases.

In all cases, black pixels (gray value = 0) and white pixels (gray value = maximum) will not be adjusted.



If you enable Gamma correction and the pixel format is set to a 10-bit or 12-bit pixel format, some image information will be lost. Pixel data output will still be 10-bit or 12-bit, but the pixel values will be interpolated during the Gamma correction process, resulting in loss of accuracy and loss of image information. If the Gamma feature is required and no image information is lost, avoid using the Gamma feature in 10-bit or 12-bit pixel format.

#### 4) Additional parameters

Depending on your camera model, the following additional parameters are available:

- a) **GammaEnable**: Enables or disables Gamma correction.
- b) **GammaMode**: You can select one of the following Gamma correction modes:

User: The Gamma correction value can be set as expected.

sRGB: The camera's internal default Gamma correction value. This feature is used with the color transformation feature to convert images from RGB to sRGB. It is recommended to adjust Gamma to sRGB mode after enabling the color transformation feature.

### 8.4.6. Sharpness

The sharpness algorithm integrated in the camera can significantly improve the definition of the edges of the image. The higher the definition, the clearer the contour corresponding to the image. This feature can improve the accuracy of image analysis, thus improving the recognition rate of edge detection and OCR.

- Enable sharpness

ON means that the sharpness feature is enabled.

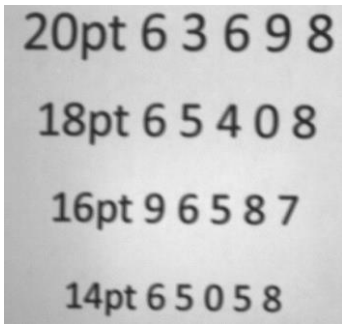

Figure 8-73 Before sharpness adjustment

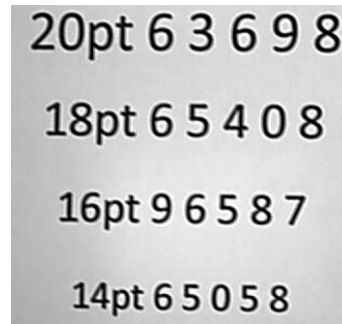

Figure 8-74 After sharpness adjustment

- Sharpness adjustment

Adjust the sharpness value to adjust the camera's sharpness to the image. The adjustment range is 0-3.0. The larger the value, the higher the sharpness.

### 8.4.7. Flat Field Correction

During the use of the camera, there may be various inconsistencies in the image, which are mainly reflected in the following aspects:

- 1) Inconsistent response of individual pixels.
- 2) The difference in gray value between the image center and the edge.
- 3) Non-uniform illumination.

The Flat Field Correction (FFC) feature can correct the inconsistency of the image. As shown below, the FFC can adjust the pixel values of different positions to the same gray value.



Figure 8-75 Before FFC

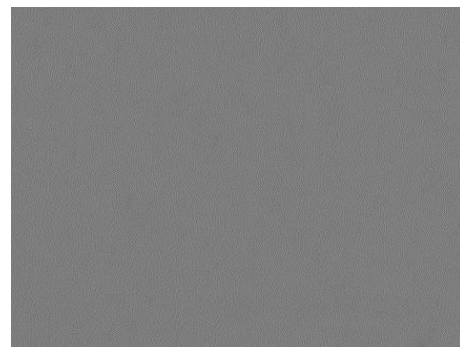

Figure 8-76 After FFC

The FFC Plugin can be used to get, save and preview the FFC coefficient. The plugin interface is shown in Figure 8-77.

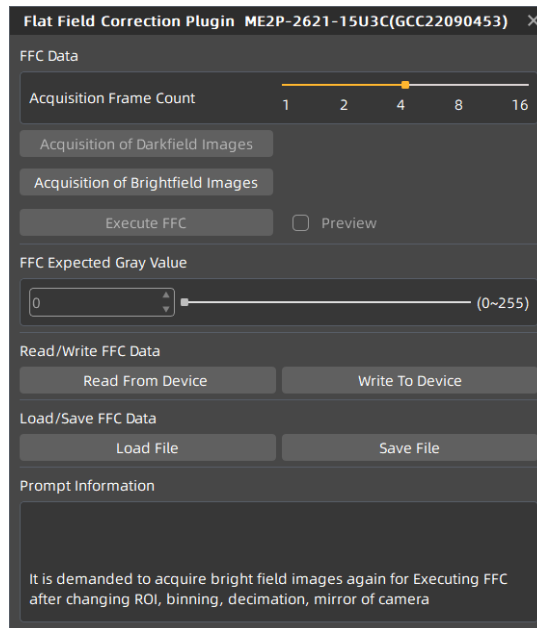

Figure 8-77 FFC Plugin interface

**i** It is demanded to acquire bright field images again for executing FFC after changing ROI, Binning, Decimation, Reverse of the VENUS2 GigE camera. The previous coefficient will no longer apply.

There are three ways to obtain the FFC coefficient:

- According to the current environment
- Read from device (available for part of the camera)
- Load file

There are two ways to save the FFC coefficient:

- Write to device (available for part of the camera)
- Save file

**i** For cameras that support FFC, In addition to the plugin, FFC can be set to on/off in the camera feature. When set to on, FFC coefficients stored in the camera can be used to calibrate the image.

The following will describe: FFC coefficient calculation and preview, FFC coefficient reading and saving, file loading and saving.

#### 8.4.7.1. FFC Coefficient Calculation and Preview

Before the FFC coefficient is obtained, it is recommended to determine the aperture of the lens and the gain of the camera. In the following cases, the coefficient needs to be re-calculated.

- Lens is replaced

- If the requirement for FFC accuracy is high (if the purpose is to correct the inconsistency of the pixels), it is recommended to recalculate the FFC coefficient after modifying the gain of the camera

According to the FFC plugin, the process of obtaining FFC coefficient is shown in the figure below, and the yellow part are optional steps. For details of the FFC plugin, please see section 9.4.

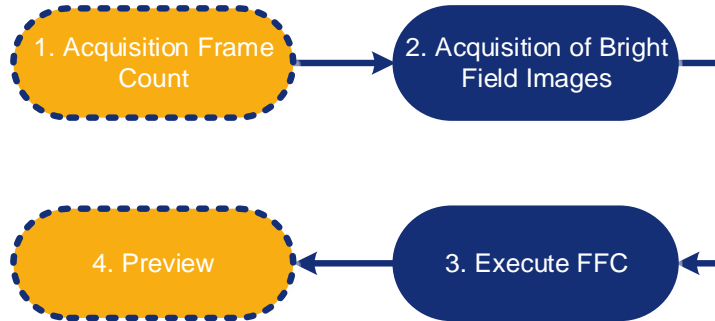

Figure 8-78 The process of obtaining FFC coefficient

**1. Acquisition frame count: frame count of acquisition frames of bright field image.**



- It is not a necessary step, generally the default value is used
- If the image noise is high, it is recommended to increase the acquisition frame count

**2. Acquisition of bright field images: perform this function to complete the bright field image acquisition.**



- It is recommended to aim at the white paper or the flat fluorescent lamp (to ensure the same amount of light in different areas of the sensor), and adjust the distance between the camera and the white paper/flat fluorescent lamp to fill the entire field of view
- Do not overexpose the image. The gray value of the brightest area of the brightfield is recommended to be less than 250
- The image should not be too dark. The gray value of the darkest area of the brightfield is recommended to be greater than 20
- It is recommended to control the bright field gray value by adjusting the exposure time or light source, and do not adjust the aperture

**3. Execute FFC: Calculate the FFC coefficient using the acquired images. After execution, the subsequent images automatically use the calculated coefficients for FFC.**

**4. Preview: Preview the effect of the current FFC.**

8.4.7.2. Read/Save Coefficient

- Read coefficient: The saved correction coefficient can be read from the device
- Save coefficient: Save the current FFC coefficient to the device. The coefficient can still be saved after the camera is powered down



Available for part of the camera models: models that implement FFC in the camera. Other models are grayed out.

#### 8.4.7.3. Load/Save File

- Load from file: Load the saved FFC coefficient file (format: .ffc) from the file
- Save to file: Save the current coefficient to the FFC coefficient file (format: .ffc)

#### 8.4.8. Lookup Table

When the analog signal that is read out by the sensor has been converted via ADC, generally, the raw data bit depth is larger than 8 bits, there are 12 bits, 10 bits, etc. The feature of lookup table is to replace some pixel values in the 8 bits, 10 bits, and 12 bits images by values defined by the user.

The lookup table can be a linear lookup table or a non-linear lookup table, created entirely by the user.

You can also use the **LUTValueAll** function to create an entire lookup table.

##### 1) How it works

- LUT is short for "lookup table", which is basically an indexed list of numbers.
- In the lookup table you can define replacement values for individual pixel values. For example, you can replace a gray value of 0 (= minimum gray value) by a gray value of 1023 (= maximum gray value for 10-bit pixel formats). This changes all completely black pixels in your images to completely white pixels.
- Setting a user-defined LUT can optimize the luminance of images. By defining the replacement values in advance and storing them in the camera to avoid time-consuming calculations. The camera itself has a factory default lookup table, and the default lookup tables do not affect image luminance.

##### 2) Creating the user-defined LUT

To create a lookup table, you need to determine the range of **LUTIndex** and **LUTValue** parameters by the maximum pixel format supported by the currently used camera.

- On cameras with a maximum pixel bit depth of 12 bits

The **LUTIndex** selectable item is 0-4095, each **LUTIndex** corresponds to a **LUTValue**, and the **LUTValue** range is [0,4095].

- On cameras with a maximum pixel bit depth of 10 bits

The **LUTIndex** selectable item is 0-1023, each **LUTIndex** corresponds to a **LUTValue**, and the **LUTValue** range is [0,1023].

Create a user-defined lookup table with the following steps:

- 1) Select the lookup table to use. Since there is only one user-defined lookup table in the camera, there is no need to select it by default.
- 2) Set the **LUTIndex** parameter to the pixel value that you want to replace with a new value.
- 3) Set the **LUTValue** parameter to the new pixel value.

- 4) Repeat steps 1 and 2 for all pixel values that need to be changed to set the parameters to the target pixel values in turn.
- 5) Set the **LutEnable** parameter to **true** means that the lookup table feature is enabled. The default is disabled.



If you want to replace all pixel values, it is recommended to use the **LUTValueAll** function. See the **LUTValueAll** sample code in the Development User Manual for details.

#### 8.4.9. HDR

HDR stands for "high dynamic range". For industry cameras, it means that the camera directly generates high dynamic range digital images. In contrast, acquiring images using traditional methods is called LDR (low dynamic range).

The dynamic range of an image (ie, contrast) is the ratio of light to dark. In other words, if the image contains both brighter and darker areas, the dynamic range is higher (e.g., an image of a person stands with his back to the sun). If the dynamic range is extremely small, the brightness can also be high because there is no darker area (e.g., facing the sun).

The HDR mode acquires two images at different exposures. Long-exposure image and short-exposure image merged into one HDR image. The HDR image retains both dark details in the high-brightness image and the bright details in the low-brightness image.

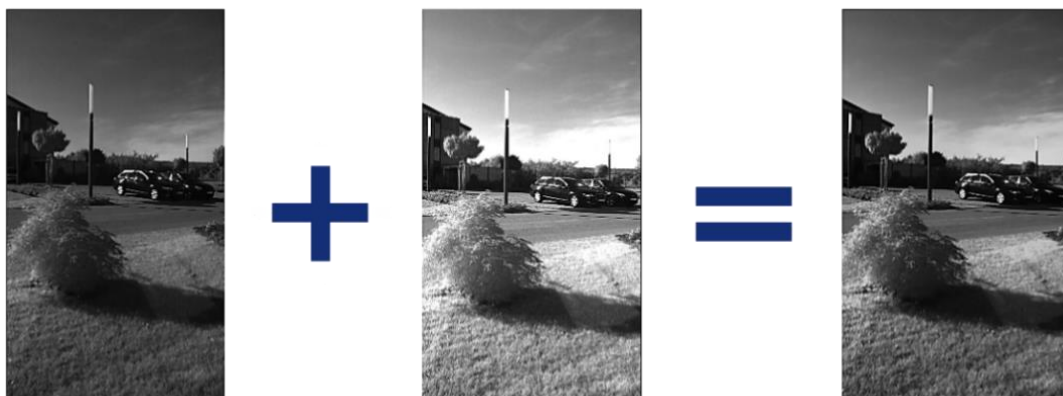

Figure 8-79 HDR diagram

#### 8.4.10. Noise Reduction

During the digitization and transmission of an image, it is often disturbed by the noise of the imaging device and the external environment, which will cause the image with noise. The process of reducing or suppressing the noise in the image is called image noise reduction.

Adjust the noise reduction value can adjust the noise reduction intensity of the camera on the image. The adjustment range is 0-4.0. The larger the value, the higher the degree of noise reduction.

Noise reduction feature: determine whether to enable noise reduction. ON means that the noise reduction feature is enabled. And OFF means that the noise reduction feature is disabled.

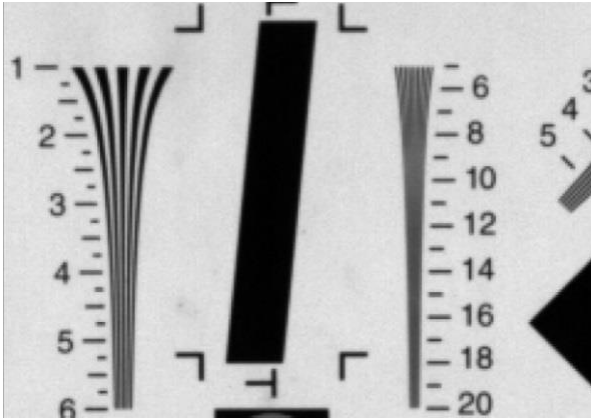

Figure 8-80 Before noise reduction

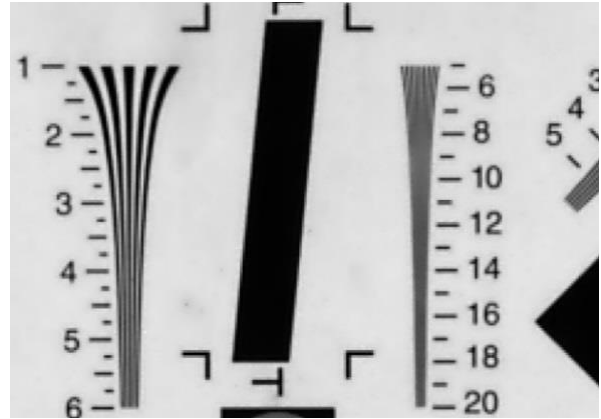

Figure 8-81 After noise reduction

### 8.4.11. Hue

Some cameras support hue function. Hue function can changes the hue (intensity) of the colors to make the colors in the image more coordinated and unified to achieve the goal image effect.

#### 1) Prerequisites

If the **HueEnable** parameter is available, it must be set to **On**.

#### 2) Configuring hue

Enter the expected value for the hue parameter and the range is -180 to 180. By default, the parameter is set to 0 (no hue perform).

#### 3) How it works

The hue adjustment is performed by a  $3 \times 3$  matrix. When the hue intensity is modified, the hue can be changed by modifying the adjustment matrix  $A$ .

$$\begin{bmatrix} R_{out} \\ G_{out} \\ B_{out} \end{bmatrix} = \begin{bmatrix} RR & RG & RB \\ GR & GG & GB \\ BR & BG & BB \end{bmatrix} \begin{bmatrix} R_{in} \\ G_{in} \\ B_{in} \end{bmatrix} \quad A = \begin{bmatrix} RR & RG & RB \\ GR & GG & GB \\ BR & BG & BB \end{bmatrix}$$

#### 4) Effect images



Figure 8-82 Before hue



Figure 8-83 After hue

### 8.4.12. Contrast

The Contrast can change the degree of difference between light and dark areas in the image, for increase or decrease the difference between the foreground and background areas of the image.

#### 1) Prerequisites

If the **ContrastEnable** parameter is available, it must be set to **SCurve**.

#### 2) Enabling Contrast

To enable contrast, use the **ContrastValue** parameter. The **ContrastValue** parameter's range is -150 to 150.

- a) Contrast = 0.0: the contrast remains unchanged.
- b) Contrast < 0.0: the contrast decreases.
- c) Contrast > 0.0: the contrast increases.

The more the contrast increased, the more the dynamic range of the processed image will be, and the image will appear more defined.



Figure 8-84 Before contrast



Figure 8-85 After contrast



It takes a long time to adjust the contrast function, so it is not recommended to modify the relevant parameters frequently during the acquisition process.

### 8.4.13. Brightness

The Brightness can lighten or darken the image to achieve the goal image effect.

#### 1) Prerequisites

If the **BrightnessEnable** parameter is available, it must be set to **Curve**.

#### 2) Enabling Brightness

To enable brightness, use the **BrightnessValue** parameter. The **BrightnessValue** parameter's range is -150 to 150.

- a) Brightness = 0.0: the overall brightness remains unchanged.
- b) Brightness > 0.0: the overall brightness increases.
- c) Brightness < 0.0: the overall brightness decreases.

In all cases, the parameter set to black (gray value = 0) or white (gray value = maximum value) which that the brightness remains unchanged.

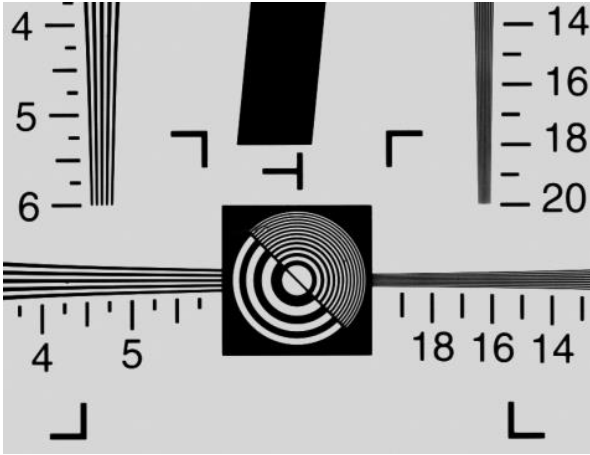

Figure 8-86 Before brightness

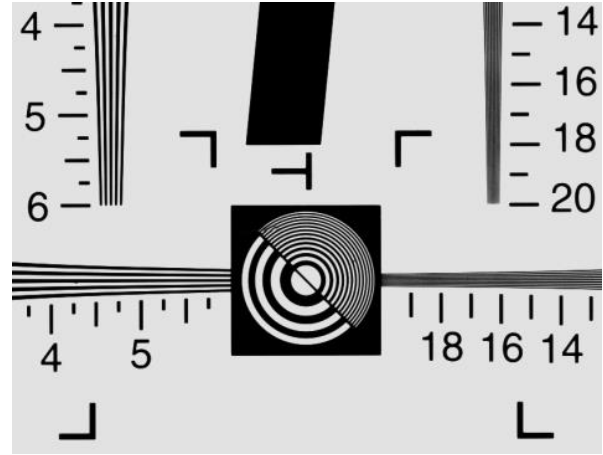

Figure 8-87 After brightness

**i** It takes a long time to adjust the brightness function, so it is not recommended to modify the relevant parameters frequently during the acquisition process.

## 8.5. Image Transmission

### 8.5.1. Calculate Frame Rate

#### 1) Frame Period

You can calculate the frame period of the VENUS2 GigE series camera by the following formula:

$$T_f = \text{Max} \left( \frac{\text{ImageSize} \times 10^6}{\text{GevLinkSpeed}}, T_{\text{acq}}, T_{\text{exp}} \right)$$

Among them:

$$\text{ImageSize} = \text{Width} \times \text{Height} \times \text{PixelSize} + 74 \times \text{CompletePacketNum} + 268$$

$T_f$ : The camera's frame period, unit:  $\mu\text{s}$ .

Width: The current image width.

Height: The current image height.

PixelSize: The size of the pixel, in 8bit mode, the value is 1, and in 10bit/12bit mode, the value is 2.

CompletePacketNum: The number of the complete packets,  $Width \times Height \times PixelSize / (Packet Size - 36)$ , round down.

CompletePacketNum: The number of the complete packets,  $Width \times Height \times PixelSize / (Packet Size - 36)$ , round down.

GevLinkSpeed: The speed of the network connect speed, unit: Bps.

$T_{acq}$ : The acquisition time of the camera, unit:  $\mu s$ .

$T_{exp}$ : The exposure time of the camera, unit:  $\mu s$ .

2) Frame rate (Unit: fps)

$$F = \frac{10^6}{T_f}$$



It is recommended to use the frame rate calculation tool, the frame rate will be calculated automatically after the configuration parameters are filled.

### 8.5.2. Maximum Allowable Frame Rate

1) The maximum allowable frame rate of the network

The maximum allowable frame rate of the network is the camera's maximum transmission frame rate that the current network supports. The maximum frame rate that the VENUS2 GigE camera network supports is determined by the camera's resolution, pixel format (Pixel Size), and the valid network bandwidth. It can be expressed by the formula:

The maximum allowable frame rate of the network = the valid network bandwidth/ resolution/ Pixel Size

**Example 1:** The camera resolution is 1628\*1236, the pixel format is BayerRG8, packet size is 1500 bytes, packet delay is 1000. The current valid network bandwidth is 468Mbps.

The maximum allowable frame rate of the network =  $468Mbps / (1628*1236)/8 = 29$  fps

The maximum allowable frame rate of the network is 29fps, and the camera meets the front-end sensor's maximum acquisition frame rate of 29fps. In addition to the limitations of network bandwidth, the maximum working frame rate of the camera is affected by the following two factors:

- Usually, the camera front-end sensor readout time and the camera internal transfer time is called the camera acquisition time. The camera acquisition time is affected by the ROI which is set by the user
- The camera's exposure time

2) The calculation of the camera's acquisition time

The camera's acquisition time is related to the OffsetY and the height of the ROI. When the OffsetY and height of the ROI is changed, it will affect the front-end acquisition frame period of the camera, then affect the acquisition frame rate.

The formulas are as follows:

- VE2S-042-121GM/C-P

When the pixel format is Mono8 or BayerRG8, the row period (unit:  $\mu\text{s}$ ):

$$T_{\text{row}} = \frac{535}{37.5} = 14.267$$

When the pixel format is Mono10 or BayerRG10, the row period (unit:  $\mu\text{s}$ ):

$$T_{\text{row}} = \frac{1070}{37.5} = 28.533$$

The camera acquisition time (unit:  $\mu\text{s}$ ):

$$T_{\text{acq}} = (\text{Height} + 30) \times T_{\text{row}}$$

- VE2S-161-75GM/C-P

When the pixel format is Mono8 or BayerRG8, the row period (unit:  $\mu\text{s}$ ):

$$T_{\text{row}} = \frac{552}{46.88} = 17.775$$

When the pixel format is Mono10 or BayerRG10, the row period (unit:  $\mu\text{s}$ ):

$$T_{\text{row}} = \frac{1104}{46.88} = 23.549$$

The camera acquisition time (unit:  $\mu\text{s}$ ):

$$T_{\text{acq}} = (\text{Height} + 30) \times T_{\text{row}}$$

- VE2S-303-37GM/C-P

When the pixel format is Mono8 or BayerRG8, the row period (unit:  $\mu\text{s}$ ):

$$T_{\text{row}} = \frac{506}{37.5} = 13.440$$

When the pixel format is Mono12 or BayerRG12, the row period (unit:  $\mu\text{s}$ ):

$$T_{\text{row}} = \frac{1012}{37.5} = 26.880$$

The camera acquisition time (unit:  $\mu\text{s}$ ):

$$T_{\text{acq}} = (\text{Height} + 38) \times T_{\text{row}}$$

- VE2S-501-23GM/C-P

When the pixel format is Mono8 or BayerRG8, the row period (unit:  $\mu\text{s}$ ):

$$T_{\text{row}} = \frac{506}{37.5} = 13.440$$

When the pixel format is Mono12 or BayerRG12, the row period (unit:  $\mu\text{s}$ ):

$$T_{\text{row}} = \frac{1012}{37.5} = 26.880$$

The camera acquisition time (unit:  $\mu\text{s}$ ):

$$T_{\text{acq}} = (\text{Height} + 38) \times T_{\text{row}}$$

- VE2S-630-18GM/C-P

The row period (unit:  $\mu\text{s}$ ):

$$T_{\text{row}} = \frac{720}{37.647} = 19.126$$

The camera acquisition time (unit:  $\mu\text{s}$ ):

$$T_{\text{acq}} = (\text{Height} + 42) \times T_{\text{row}}$$

### 3) The camera's acquisition frame rate

In addition to the maximum allowable bandwidth of the network and the time limit for camera acquisition, the exposure time can also affect the frame rate. For example: when the exposure time is 100ms, the corresponding frame rate is 10fps.

In conclusion, the frame rate of the camera takes the minimum of the maximum allowable frame rate of the network, the acquisition frame rate and the exposure frame rate.

### 8.5.3. Stream Channel Packet Size

Stream channel packet size (SCPS) refers to the network packet's size of the stream channel data which is transferred to the host terminal by the camera, in bytes and the default value is 1500. It includes the IP header, UDP header and GVSP header which the total length is 36 bytes, so the payload in the default channel network packet is 1464 bytes. The recommended maximum packet size is 8192 bytes, which can improve the network transmission performance.



- 1) When the packet size is set to more than 1500, it needs the network equipment such as network card and switch to support the jumbo frames.
- 2) When changing the packet size, the packet size and the packet delay will affect the network transfer performance together.

### 8.5.4. Stream Channel Packet Delay

The stream channel packet delay (SCPD) is used to control the bandwidth of the image streaming data of the camera. The packet delay is the number of the idle clocks that inserted between adjacent network packets transmitted in the stream channel. Increase the packet delay can reduce the camera's bandwidth usage, and it may also reduce the camera's frame rate (the camera frame rate also depends on the exposure time, camera acquisition time).

The camera's packet size, packet delay and reserved bandwidth determine the effective network bandwidth. The effective network bandwidth is calculated as follows:

The time required to transmit a single stream packet:

$$T_{\text{data}} = (\text{Size}_{\text{pkt}} \times 8\text{bits}) / \text{Speed}_{\text{link}}$$

The time of packet delay is:

$$T_{\text{delay}} = \text{Delay}_{\text{pkt}} / 125,000,000$$

Among them: the  $\text{Size}_{\text{pkt}}$  is packet size,  $\text{Delay}_{\text{pkt}}$  is packet delay,  $\text{BandW}_{\text{reserve}}$  is reserved bandwidth,  $\text{Speed}_{\text{link}}$  is link speed.

Effective network bandwidth:

$$\text{BandW}_{\text{avial}} = ( \text{Size}_{\text{pkt}} \times 8\text{bits} \times ( 1 - \text{BandW}_{\text{reserve}} ) ) / ( T_{\text{data}} + T_{\text{delay}} )$$

**Example 1:** The packet size is 1500, the packet delay is 1000, the reserved bandwidth is 20%, and the link speed is 1Gbps.

The time to transport a single stream packet is:

$$T_{\text{data}} = (1500 \times 8) / 1000,000,000 = 12\mu s$$

The time of packet delay is:

$$T_{\text{delay}} = 1000 / 125,000,000 = 8\mu s$$

The effective network bandwidth is:

$$\text{Band } W_{\text{avial}} = (1464 \times 8 \times (1-0.2)) / (12\mu s + 8\mu s) = 468\text{Mbps}$$

Note: Each stream packet contains 36 bytes of network header data, and a packet with the size of 1500 bytes contains only 1464 bytes of valid data.

**Example 2:** The packet size is 8192, the packet delay is 2000, the reserved bandwidth is 20%, and the link speed is 1Gbps.

The time to transport a single stream packet is:

$$T_{\text{data}} = (8192 \times 8) / 1000,000,000 = 66\mu s$$

The time of packet delay is:

$$T_{\text{delay}} = 2000 / 125,000,000 = 16\mu s$$

The effective network bandwidth is:

$$\text{Band } W_{\text{avial}} = (8156 \times 8 \times (1-0.2)) / (66\mu s + 16\mu s) = 637\text{Mbps}$$

### 8.5.5. Bandwidth Reserve

The Bandwidth Reserve is used to reserve a part of bandwidth for packet retransmission and control data transfer between the camera and the host, and can be used for multiple cameras transmission, to limit the bandwidth allocation of each camera. For example, the network bandwidth is 1Gbps, setting the reserved bandwidth value to 20%, then the bandwidth will be reserved to 0.2Gbps. When the maximum bandwidth required for transmission is greater than the current bandwidth available, the camera reduces the frame rate to ensure the stability of the transmission.

### 8.5.6. Transfer Control

When multiple cameras are connected to the host by switches, if trigger these cameras to acquire images at the same time, when transmitting the images, because of the instantaneous bandwidth of the switch is too large, and the storage capacity is limited, data loss will occur. Therefore, the user needs to use frame transfer delay to avoid this problem.

In trigger mode, by setting the Transfer Control Mode as "User Controlled", when the camera receives software trigger command or hardware trigger signal and completes the image acquisition, the camera will save the images in the frame buffer which is internal the camera, waiting for the host to send the "Acquisition Start" command, the camera will transmit the images to the host. The transmission delay time is determined by the host. When multiple cameras are triggered simultaneously, different transmission delay can be set for each camera to avoid the instantaneous bandwidth of the switch is too large.



The Transfer Control function is valid only in trigger mode.

### 8.5.7. Frame Store Control

The Frame Storage Control function is used to control the maximum number of images which stored in the cache. Configurable parameters are as follows:

**Frame Store Coverage:** When the average bandwidth of the data written in the internal frame is greater than the average bandwidth of the data read from it, then the frame store will be full. If the frame store is full, the image data will be overwritten.

**Frame Buffer:** The frame count of the camera.

**Frame Buffer Flush:** Clear the previous data of frame buffer.

Restrictions on Frame Buffer Flush function:

- 1) In trigger mode, the frame buffer flush command will be ignored while in acquisition process.
- 2) The frame buffer flush command will be ignored while in passive data transmission process.
- 3) Able to use when trigger mode is on and in UserControlled (Transmission control mode)

## 8.6. Events

When event notification is set to "on", the camera can generate an "event" and transmit a related event message to the host whenever a specific situation has occurred. For VENUS2 GigE camera, the camera can generate and transmit events for the following situations:

- The camera has ended exposure (ExposureEnd)
- An image block is discarded (BlockDiscard)
- The trigger signal overflow (FrameStartOvertrigger)

- The image frame block is not empty (BlockNotEmpty)
- The event queue is overflow (EventOverrun)

Every event has a corresponding enable status, and in default all the events' enable status are disable.

When using the event feature, you need to enable the corresponding event firstly and set the port of the event channel, the timeout of the event retransmission, and the number of times the event retransmission to the camera. When the retransmission timeout of the event is set to 0, the event sent by the camera will not require the host to return the reply packet. When the port value of the event channel is set to 0, the camera will not send the event to the host. In other cases, the camera needs to receive a host reply packet before sending the next event. When the event that the camera sends does not receive the reply packet, the camera will retransmit the event according to the retransmission timeout and retransmission times.

The effective information contained in each event is shown in Table 8-2:

No.	Event Type	Information
1	ExposureEnd Event	Event ID
		Frame ID
		Timestamp
2	BlockDiscard Event	Event ID
		Timestamp
3	EventOverrun Event	Event ID
		Timestamp
4	FrameStartOvertrigger Event	Event ID
		Frame ID
		Timestamp
5	BlockNotEmpty Event	Event ID
		Timestamp
6	FrameBurstStartOvertrigger Event	Event ID
		Frame ID
		Timestamp
7	FrameStartWait Event	Event ID
		Timestamp
8	FrameBurstStartWait Event	Event ID
		Timestamp
9	ActionLate Event	Event ID
		Timestamp

Table 8-2 The effective information of each event

Among them: the timestamp is the time when the event occurs, and the timer starts when the camera is powered on or reset. The bit width of the timestamp is 64bits, and the unit is 8ns.

### 8.6.1. ExposureEnd Event

If the ExposureEnd Event is enabled, when the camera's sensor has been exposed, the camera sends out an ExposureEnd Event to the host, indicating that the exposure has been completed.

### 8.6.2. BlockDiscard Event

When the average bandwidth of the write-in data is greater than the average bandwidth of the read-out data, the frame buffer may overflow. If the frame buffer is full and the camera continue to write image data to it, then the new data will overwrite the previous image data which has been in the frame buffer. At this moment, the camera sends a BlockDiscard event to the host, indicating that once image discard event has occurred. So, when you read the next frame of image, the image is not continuous.

### 8.6.3. BlockNotEmpty Event

When the average bandwidth of the read-in data is greater than the average bandwidth of the readout data, if the frame buffer is not full, and there has image frame data in the frame buffer which has not been send out completely, then before the new image frame is written to the frame buffer, the camera will send a BlockNotEmpty event to the host, indicating that the previous image has not been send out completely when the new image is written in the frame buffer.

### 8.6.4. FrameStartOvertrigger Event

When the camera receives the FrameTrigger hardware trigger signal or software trigger signal, if the front-end sensor is exposing, it will not be able to respond to the new FrameTrigger signal, then the camera will send a FrameStartOvertrigger event to the host. Note that if multiple FrameTrigger signals are received within one frame acquisition period, the camera sends only one FrameStartOvertrigger event.

### 8.6.5. EventOverrun Event

Inside the camera, there has an event queue which is used for caching events. Usually, the event data packet which is sent to the host only contains one event. When there are multiple events occur simultaneously, or when the event transmission is delay, the user can use event queue inside the camera to cache the events. When an event can be sent, the camera will send all the events cached in the queue, at this time the event data packet which is sent to the host contains multiple events. But if the camera is running in a high frame rate mode, and send several events that exceed the camera cache, at this time, if the EventOverrun event is enable, the camera will send an EventOverrun event to the host, and discard all the events in the current cache.

### 8.6.6. FrameBurstStartOvertrigger Event

When the camera is in FrameBurstStart trigger mode, when it receives an AcquisitionTrigger hardware trigger or software trigger signal, if the front-end sensor is exposing, it will not be able to respond to the new AcquisitionTrigger signal, and the camera will send a FrameBurstStartOvertrigger event to the host. Note that the camera will send the corresponding number of FrameBurstStartOvertrigger events if it receives multiple AcquisitionTrigger signals during the acquisition period of one frame of image.

### 8.6.7. FrameStartWait Event

When the camera is in FrameTrigger mode, the camera starts acquiring images, and if it does not receive the FrameTrigger signal, the camera will send a FrameStartWait event to the host.

### 8.6.8. FrameBurstStartWait Event

When the camera is in the AcquisitionTrigger mode, the camera starts acquiring images. If the camera does not receive the AcquisitionTrigger signal, the camera sends a FrameBurstStartWait event to the host. Note that if the FrameTrigger mode is set to on simultaneously with the AcquisitionTrigger mode, the FrameBurstStartWait event will be sent first. When the camera receives an AcquisitionTrigger signal, it will send a FrameBurstStartWait event.

### 8.6.9. ActionLate Event

After the camera has enabled the PtpEnable function, the camera starts PTP Clock Synchronization. In this operating mode, the camera can receive a ScheduleAction command, which can include a specified timestamp value and make the camera to complete an action at that timestamp, such as acquiring an image. If the timestamp value included in the ScheduleAction command is less than the value of the camera's current timestamp, the camera will immediately execute the Action and send an ActionLate event (if this event is enabled at this time).

## 9. Software Tools

### 9.1. GigE IP Configurator

You can set the IP Address and IP Configuration by **GxGigEIPConfig**.

- **Guidance**

Menu bar → Tools → GxGigEIPConfig, see Figure 9-1:

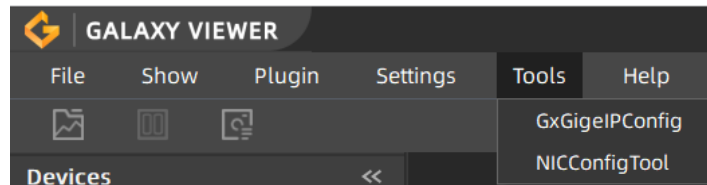

Figure 9-1

See GxGigEIPConfig interface as Figure 9-2:

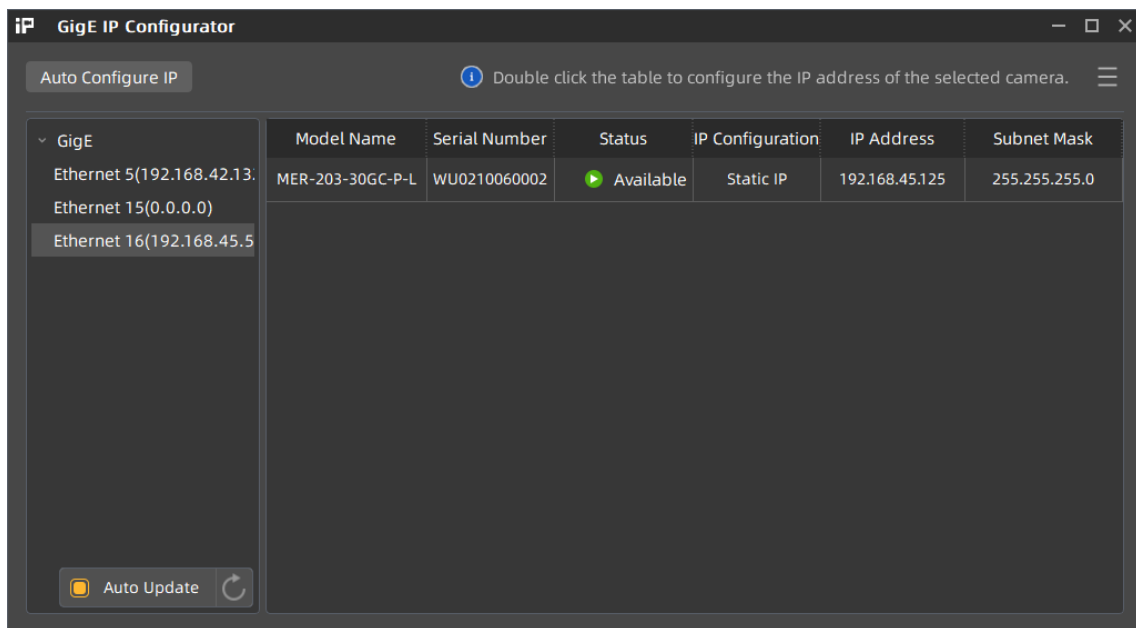



Figure 9-2 GxGigEIPConfig interface

The left side of the interface is device list, showing all searched GigE (Gigabit Ethernet)

- 1) When GigE is selected, all GigE cameras will be shown in the right side.
- 2) When selecting a certain GigE, the right side will only show the corresponding GigE cameras, and if you want to change the Ethernet attributes, just right click it.



- 1) **Auto Update** will enumerate devices automatically in every 2s, you can also click "  " to update devices manually.
- 2) The essential information are listed in the right side, click "  " in the top right-hand corner to set.

● **Status and operations**

Status: Available, Read Only, Occupy, Unreachable, Unknown.

Operations: Auto Configure IP, Modify IP Address, Release Occupation, Reset Device.





Icon	Status	Description	Operation
	Available	When the camera is not opened in Exclusive or Control mode by other processes. And the camera IP can be modified manually	1) Modify IP Address 2) Reset Device
	Read Only	When the camera is opened in Control mode by other processes. By this time, the Auto Configure IP and Modify IP Address will be forbidden	1) Release Occupation 2) Reset Device
	Occupy	When the camera is opened in Exclusive mode by other processes. By this time, the Auto Configure IP and Modify IP Address will be forbidden	1) Release Occupation 2) Reset Device
	Unreachable	Three conditions when in Unreachable status: 1) The current camera IP is same as other camera IP 2) The current camera IP is same as network card IP 3) The current camera IP and the connected network card are not in the same subnet	1) Modify IP Address 2) Auto Configure IP
	Unknown	Cannot get the current accessible state for some reason	1) Modify IP Address

Table 9-1 Device status description

Valid IP: Non LLA address, non 0.0.0.0.

● **Auto Configure IP**

By this function, all unreachable camera's IP will be changed to the effective IP, which has the same network segment as the PC network port.

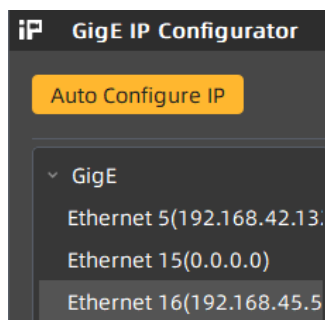

Figure 9-3



If the host network card IP is invalid, then after Auto Configure IP operation, it will be valid.

● **Modify IP Address**

Users can double click the row of the camera in the list, the window as Figure 9-4:

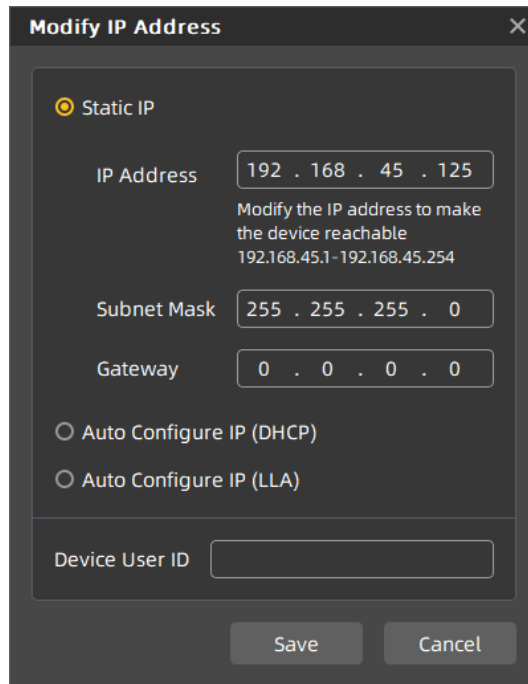

Figure 9-4 Modify IP Address

The default setting is **Static IP**, and in here, users can set **IP Address**, **Subnet Mask** and **Gateway**.



It is restrict to set the IP as: class D (224~239), Class E (240~254), IP start with 127 or 255. There will be an error prompt if you set the restrict IP or wrong format IP, in this case, **Save** is not available. See Figure 9-5.

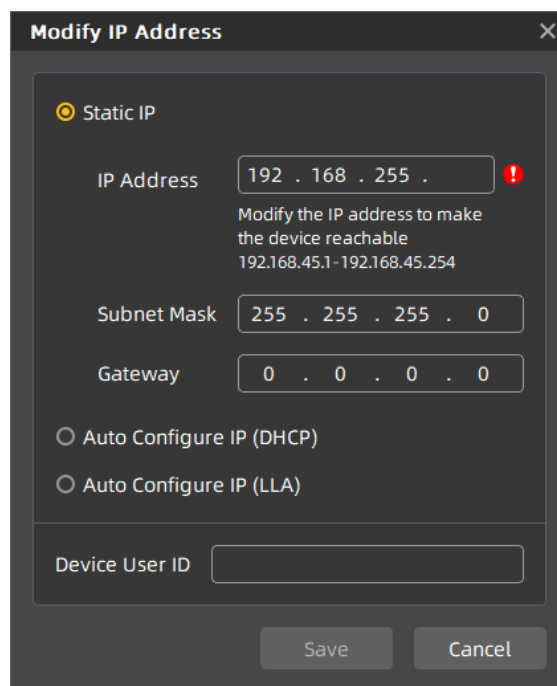

Figure 9-5 IP address format check

Users can set Static IP, DHCP or LLA according to their needs.

IP Configuring Type	Description
Static IP	Default configuration, which is saved in the camera Flash sensor and cannot be changed while power on/off
DHCP	When start with DHCP, please ensure that DHCP server is configured in your network environment, otherwise, the camera will restart in LLA address after waiting DHCP server assign IP overtime. But when DHCP server occurs, the camera IP will switch to DHCP assigned address, the default factory configuration of the camera is DHCP
LLA	Link-local address, which is used for local network communication, not forwarded through routing

Optional operation: Modify Device User ID, the maximum length of user-defined name is 16 characters.

Release Occupation: The camera heart beat time is 5min by default (VS develop, in debugging status). If users forcibly exits the process without closing the camera, then the camera cannot be resetting immediately, unless the 5min heart beat time is over, and by then, the camera is in Occupy or Unreachable status. Users can double click the row of the camera in the list to release the camera and open the camera again.

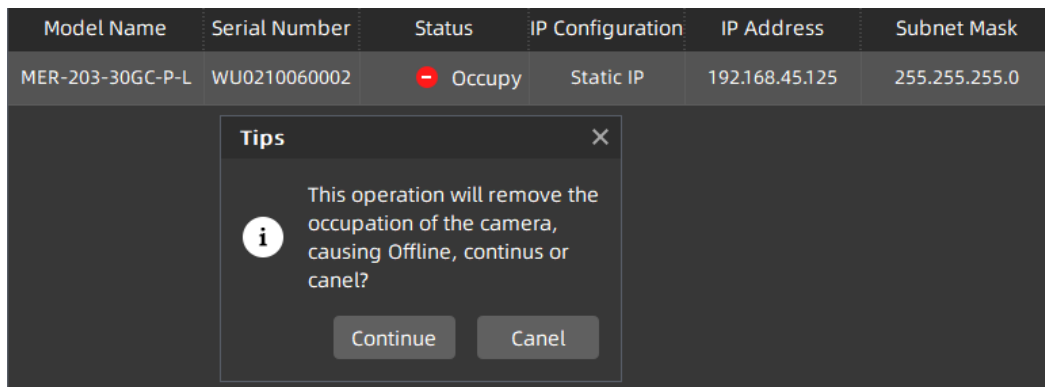

Figure 9-6

Reset Device: While users need to reload the camera and the device is not convenient to power off, then right click the row of the camera in the list and click Reset Device button.

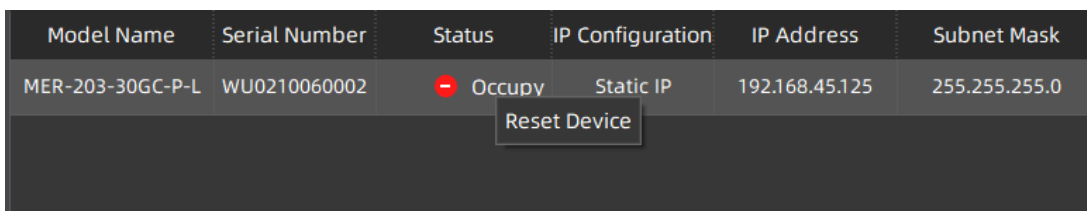

Figure 9-7

- 1) Be careful to use **Release Occupation** and **Reset Device**, they will cause the camera off-line while acquiring.
- 2) Require camera itself supports **Release Occupation** and **Reset Device**.

## 9.2. Frame Rate Calculation Tool

WidthMax	1920
HeightMax	1200
Width	1920
Height	1200
BinningHorizontal	1
BinningVertical	1
DecimationHorizontal	1
DecimationVertical	1
ExposureTime(us)	20000
ExposureDelay(us)	0
PixelFormat(8/10)	8
GevSCPSPacketSize	1500
GevSCPD	0
GevSCPDMaxValue	180000
GevFramerateABS	40.6
GevFramerateAbsEn	0
LinkSpeed(Kbps)	1000
BandwidthReserve	10
BandwidthReserveMaxValue	99
F	40.61

Figure 9-8 Frame rate calculation tool

The frame rate calculation tool is currently provided in the form of Excel. When using it, firstly select the camera model in the table, and then achieve the expected frame rate by modifying the parameter of the camera. There are four major types of influencing factors, including image readout time (image width, image height, pixel format), exposure time, acquisition frame rate setting value, and image transmission bandwidth influence.

The parameters in Figure 9-8 are explained as follows:

- 1) The Width and Height are the set ROI size.
- 2) The definitions of BinningHorizontal, BinningVertical, DecimationHorizontal, DecimationVertical can refer to section 8.3.9 and section 8.3.10. These four parameters will affect the transmission time of image data.
- 3) The ExposureTime is the exposure time when the camera acquires one frame of image.
- 4) The PixelFormat is the pixel format corresponding to the camera output image, including 8 bits, 10 bits or 12 bits.
- 5) The BandwidthReserveMaxValue represents the maximum reserved bandwidth when the camera transmits images.
- 6) The BandwidthReserve represents the recommended maximum reserved bandwidth of the camera. If this reserved bandwidth is exceeded, frame loss may occur.
- 7) The GevFramerateABS represents the maximum value of the GevFramerateAbsEn when GevFramerateAbsEn is enabled. Whether the maximum value can be reached depends on whether the camera is affected by other acquisition parameters.

- 8) The `GevFramerateAbsEn` indicates whether frame rate control is enabled, 1 means enable `GevFramerateAbsEn`, and 0 means disable `GevFramerateAbsEn`. When `GevFramerateAbsEn` is enabled, the camera acquires images at a frame rate that is no higher than the `GevFramerateABS`. When `GevFramerateAbsEn` is disabled, the camera acquires images without being affected by the `GevFramerateABS`.

When using the frame rate calculation tool, please fill in the above information of the camera into the corresponding table. When the filled value exceeds the range or does not conform to the rules, the calculation tool will report an error. Please modify and fill in the value again according to the prompt information. When all parameters are correctly filled in, the FPS shown in the last column of the table is the theoretical frame rate currently acquired by the camera, and usually the error between this value and the actual frame rate acquired by the camera is no more than 1%.

Take the VE2S-501-23GM/C-P camera as an example:

- 1) If you want to set the camera's acquisition frame rate to 20fps with the "`GevFramerateABS`" function, you can set "`GevFramerateAbsEn`" to 1, set "`GevFramerateABS`" to 20, and then you can check "F" as 20fps.
- 2) If you want to adjust "`GevSCPSPacketSize`" and "`GevSCPD`" to make the frame rate of the camera reach 20fps, you can select the "`GevSCPSPacketSize`" you want to use. If you set "`GevSCPSPacketSize`" to 1500, then gradually set the value of "`GevSCPD`" to make "F" approach 20fps. After several attempts, it can be concluded that when "`GevSCPD`" is set to 100, the calculated result "F" is 20.05fps.

## 9.3. LUT Create Tool

### 9.3.1. GUI

LUT Create Tool, which supports all series of DAHENG IMAGING cameras. This plugin is integrated into `GalaxyView.exe`. After opening the device that you want to operate through this software, you can open LUT Create Tool from the menu bar plugin list. With the plugin you can achieve the following functions:

- 1) Adjust the image Gamma, brightness, and contrast.
- 2) Read the saved LUT from device.
- 3) Write the adjusted LUT to device.
- 4) Read the saved LUT from LUT /CSV file.
- 5) Save the adjusted LUT to file.

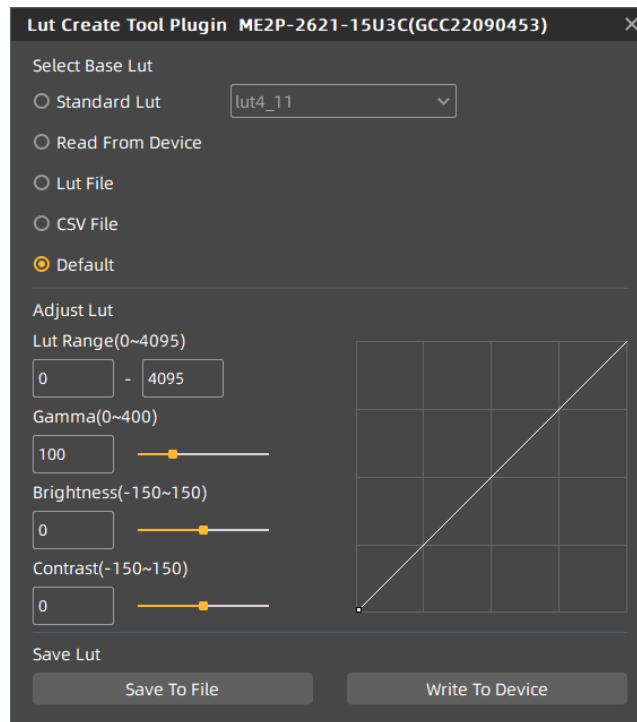

Figure 9-9 The GUI of LUT Create Tool

After opening the device and LUT Create Tool through GalaxyView.exe, the initial GUI is shown in Figure 9-9. The layout and function description of widgets are as follows:

[Select Base LUT] Include Standard LUT, Read From Device, LUT File, CSV File and Default options. Among them, standard LUT is eight groups of factory standard LUTs. Read from device is the LUT that can be read from device. LUT/CSV file can read the saved values. Default mode is the camera factory default value.

[Adjust LUT] Adjust the LUT range, Gamma, brightness, and contrast to add effects on base LUT.

[Save LUT] Write the currently generated LUT to device or save to LUT/CSV file.

[Polyline Drawing Area] Represent the currently generated LUT in a curve form.

### 9.3.2. User Guide

#### 9.3.2.1. User Case

After you select "Select Base LUT" and adjust the LUT parameter to a satisfactory effect, if you want to save the currently set parameters and you want to restore the parameters after the camera is powered on again, you need to select "Write To Device". The LUT parameter will be written to the UserSet0. After the device is powered on again, select the "Read From Device" in the "Select Base LUT" to load the UserSet0 and restore the parameter value.

If the device does not support read/write LUT, or does not support LUT to be used on other terminal devices after adjusting LUT effect through this terminal, then you can use the "Save To File" function. After adjusting LUT, select "Save To File" and choose the save format as .lut. Then select the "LUT File" in "Select Base LUT" again and select the saved LUT file to restore the parameters. If you copy the file to another terminal and read it, you can still restore the parameters.

### 9.3.2.2. Select Base LUT

#### 1) Standard LUT

When selecting Standard LUT in "Select Base LUT", the drop-down list box is enabled, which contains eight sets of optional standard LUT, as shown in Figure 9-10. These eight sets of values are factory set, which can achieve the optimal image effect. When you choose different standard LUT, the polyline and image effects change. You can modify the LUT range, Gamma, brightness, contrast values to add image effects until you are most satisfied.

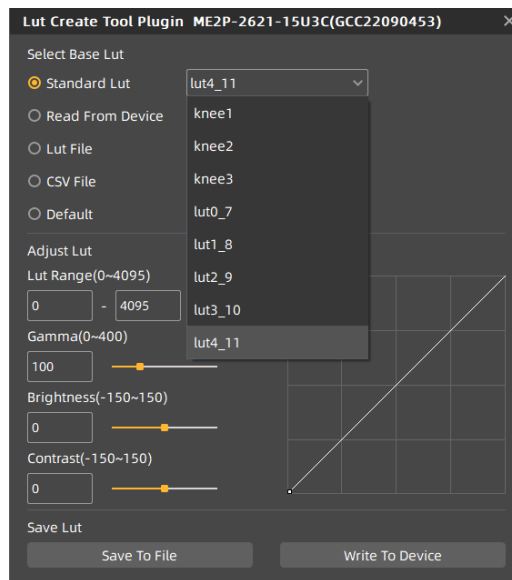

Figure 9-10 Standard LUT

#### 2) Read From device

After selecting Read From Device, UserSet0 will be loaded automatically, and then load the LUT saved by the device. If the device supports LUTEnable function, it will automatically set LUTEnable to true to display the image effect in real time, the GUI is as shown in Figure 9-11 ( **Read From Device** disabled ).

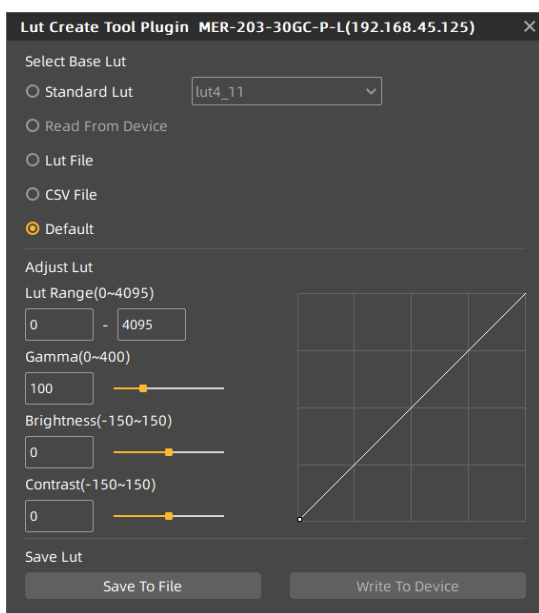

Figure 9-11 "Read From Device" disabled

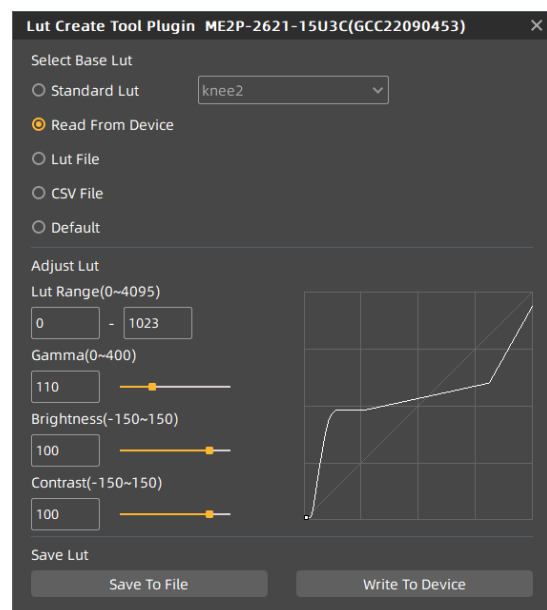

Figure 9-12 Select "Read From Device"

When selecting "Read From Device", the polyline graph and image effects are updated to the lookup table in the device. When selecting the Standard LUT or Default and selecting "Write To Device", then when reading, the written parameters will be updated to the GUI. For example, Standard LUT selects knee2, LUT Range input 0-1023, Gamma input 110, brightness input 100, Contrast input 100, and the GUI after selecting "Write To Device" is shown in Figure 9-12.

### 3) LUT file

After selecting the LUT file, a dialog box for selecting the file will pop up. You can select the file in the format of .lut, and update the polyline diagram and image acquisition effect of the device. If you select Standard LUT or Default to adjust and save LUT, the widget interface will update the parameters stored when saving LUT (the updated parameter values include LUT range, Gamma, brightness, contrast, and the values selected by the standard LUT drop-down box).

### 4) CSV file

After selecting CSV file, a dialog box for selecting the file will pop up. You can select the file in the format of .csv, and update the polyline diagram and image acquisition effect of the device. After selecting CSV file, all widgets of Auto Create LUT are disabled and unadjustable, as shown in Figure 9-13.

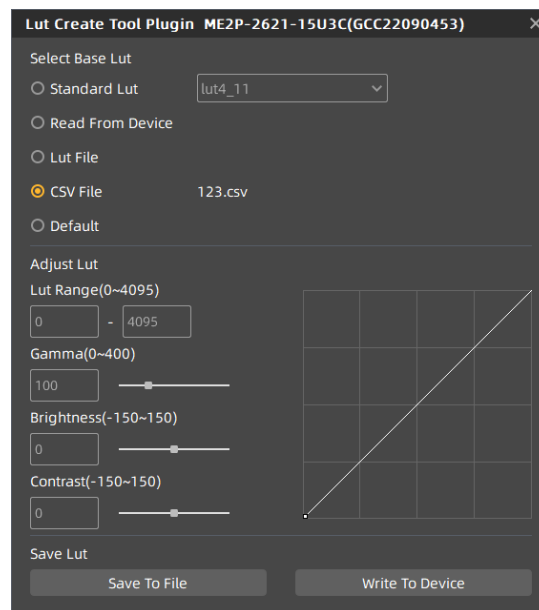

Figure 9-13 Select CSV file

CSV file can be manually modified by users. Currently, csv storage format saves decimal number of every four bytes to the first cell of each line in the file, and the maximum value of the number in each cell is 4095, a total of 4096 lines. The polyline graph of the GUI updates the curve according to the number of the first line of every 16 lines. Failure to follow the format when manually modifying will result in failure to read the file.

### 5) Default

The default option is the LUT data when the device is shipped from the factory, and is the initial value in each situation. If there is an error in other situation, it will automatically switch to the default. The default polyline graph is diagonal.

### 9.3.2.3. Auto Create LUT

There are five sets of parameters in Auto Create LUT, the maximum LUT range (default value 4095, range 0~4095), minimum value (default value 0, range 0~4032), Gamma (default value 100, range 0~400), brightness (default value 0, range -150~150), contrast (default value 0, range -150~150), where the difference between the maximum and minimum values of the LUT range needs to be greater than or equal to 63.

After selecting the Select Base LUT, when the above parameters are modified, the generated LUT will be written to the device Flash in real time. At this time, the "Write To Device" is not selected. After the device is powered off and restarted, the modified parameters will be lost. The generated LUT cannot be restored by "Read From Device".

If the Select Base LUT is selected as Default or Standard LUT, then adjusting the parameter values in the LUT group to generate LUT and saving the .lut file will save the parameter values together in the file. Reading the file again will restore the saved case. If written to the device, the cameras will save and restore the parameter.

### 9.3.2.4. Save LUT

The group contains two widgets: Save To File and Write To Device.

- 1) When selecting "Save To File", the current LUT data can be saved to the file. The saved file contains two formats: .lut and .csv, The save type can be changed when saving the file. The default save path is ".\resource\gxplugins\LookUpTable\Lut12", which is the directory where the GalaxyView.exe is installed.
- 2) When "Write To Device" is selected, the current LUT data is written to UserSet0, and UserSetDefault is modified to UserSet0. UserSet0 will be loaded when reading from the device again.

### 9.3.2.5. Read LUT

There are two ways to read the .lut file saved by the plugin and set it into the camera:

- 1) Using the plugin: After selecting the LUT file, a dialog box for selecting the file will pop up. You can select the lookup table file (xxx.lut). Clicking the "Write To Device" to set the LUT file data into the camera.
- 2) Using the API interface: Read the .lut file through the ReadLutFile interface in the GxI API library and DxlImageProc library and parse it into lookup table format that can be set to the appropriate camera. The specific steps are as follows:
  - a) Get the length of the LUT.
  - b) Apply for the LUT Buffer resource of the corresponding size according to the LUT length.
  - c) Read the LUT file (xxx.lut), and get the LUT Buffer data.
  - d) Set the LUT Buffer data into the camera. (Make sure the LUTEnable is true).
  - e) Save the current LUT data to UserSet0, and synchronously set the UserSetDefault to UserSet0. When reading from the device again, the camera will load the lookup table data.

The API interface supports C/C++/C#. For specific about the interface and example programs, please refer to relevant section of "C SDK Programming Reference Manual", "C++ SDK Programming Reference Manual" and "DotNET SDK Programming Reference Manual".

### 9.3.3. Precautions

#### 9.3.3.1. Read From Device

When reading from device, UserSet0 will be loaded, which will cause the previously modified device feature information to be lost. Therefore, the information should be saved in time before reading from device.

#### 9.3.3.2. Write To Device

In order to ensure that the device will restore the effect before power off after the device is power-on again. When writing to device, it will set the parameter set to UserSet0 and set the UserSetDefault to UserSet0. If you do not want to restore the case and the LUT in the flash after powering off and restarting the device, please use the "Write To Device" function with caution.

#### 9.3.3.3. Directory Structure

When reading/writing LUT and Auto Creat LUT, you need to rely on some files in the installation package directory, so do not arbitrarily change the installation package directory structure to avoid read/write failure.

## 9.4. Flat Field Correction Plugin

ShadingCorrectionTool.plx is the software kit for DAHENG IMAGING camera. The plugin is integrated into GalaxyView.exe. After opening the device through this software, open the FFC plugin from the menu bar plugin list. Using the plugin, you can achieve the following functions:

- 1) Execute FFC on the current device.
- 2) Get the FFC coefficient that has been validated from the device.
- 3) Write the prepared FFC coefficient to the device to prevent the coefficient from being lost after the device is powered off.
- 4) Load the saved FFC coefficient from the file.
- 5) Save the prepared FFC coefficient to the file.

### 9.4.1. GUI

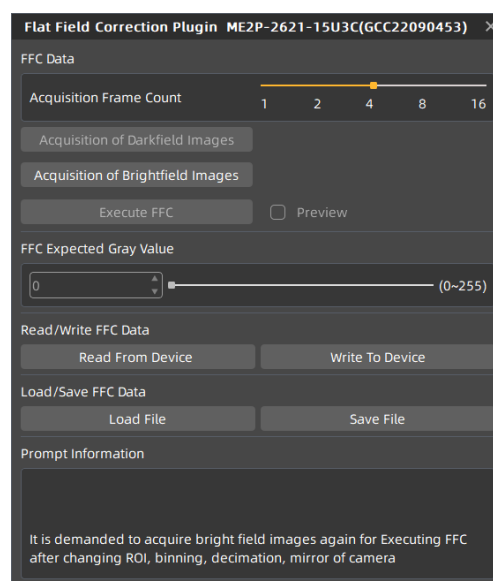

Figure 9-14 FFC plugin GUI

After opening the device through GalaxyView.exe and opening the FFC plugin, the initial state of the GUI is shown in Figure 9-14. The widgets layout and function description are as follows:

No.	Widget	Function
1	Acquisition Frame Count	The number of images acquired for the acquisition of bright field images
2	Acquisition of Bright Field Images	Acquire a certain number of bright field images. Necessary operation
3	Execute FFC	Calculate the FFC coefficient and make it Immediate effect
4	Preview	Check the effects before and after the FFC
		Enable or disable FFC Preview
5	Read from Device	If the device had executed FFC and the correction coefficient have been written to the device, the next time the camera is powered on, the FFC coefficient can be read directly from the device and take effect in real time
6	Write to Device	Write the calculated FFC coefficient to the device to prevent coefficients loss when the device is powered off
7	Load File	Load the FFC coefficient from the file and make it immediate effect
8	Save File	Save the calculated FFC coefficient to a file. When the coefficient is subsequent used, it can be loaded directly from the file
9	Prompt Information	Prompt the execution status and error message when executing FFC
10	Default prompt message	It is demanded to acquire bright field images again for executing FFC after changing ROI, Binning, Decimation, Mirror of the camera. The prompt message will always be displayed on the GUI

Table 9-2 Function description of the FFC widgets

## 9.4.2. User Guide

### 9.4.2.1. FFC Execution Steps

- 1) Set the acquisition frame count. Not necessary operation. You can skip to step 2 directly. For details, please see section 8.4.7.1
- 2) Before acquiring bright field images, you need aim the lens at white paper or the flat fluorescent lamp.
- 3) Start acquiring bright field images. For details on acquiring bright field images, please see section 8.4.7.1
- 4) Click "Execute FFC" to complete the correction.
- 5) You can view the effect before and after FFC through the preview function.
- 6) You can choose to write the correction coefficient (including the Acquisition Frame Count) to the device or save it to a file for subsequent use.

#### 9.4.2.2. Acquisition of Bright Field Images

- 1) When the device is in the stop acquisition mode, click "Acquisition of Brightfield Images", the image will be displayed in the GalaxyView acquisition GUI.
  - 2) When the device is in the acquisition mode, click "Acquisition of Brightfield image" to complete the bright field image acquisition.
  - 3) The number of bright field images acquired is related to the Acquisition Frame Count. For example, if the number of Acquisition Frame Count is set to 4, when you click "Acquiring of Brightfield Image", 4 images will be acquired for FFC calculation.
  - 4) If the brightness of the acquired bright field image is less than 20, the prompt box will show "The bright field image is too dark, it will affect the flat field correction effect, it is recommended to adjust the brightness of the image in the range of 20-250" and then re-acquiring the bright field image.
  - 5) If the brightness of the acquired bright field image is greater than 250, the prompt box will show "The bright field image is too bright, it will affect the flat field correction effect, it is recommended to adjust the brightness of the image in the range of 20-250" and then re-acquiring the bright field image.
-  1) The larger the "Acquisition Frame Count" is set, the longer it will take to acquire the bright field images.
- 2) When the color camera is acquiring bright field images, if white balance has not been done, the image after FFC is an image with white balance effect.

#### 9.4.2.3. Execute FFC

- 1) "Execute FFC" is enabled after the bright field image acquisition is completed.
- 2) Click "Execute FFC" to calculate the FFC coefficient and set it to the device to take effect in real time. If the coefficient is not written to the device, it will be lost when the device is powered down. And the FFC needs to be redone.
- 3) When the FFC is completed, the preview widget takes effect. The preview function can be used to check the effects before and after the FFC.

#### 9.4.2.4. Read FFC Data from Device / Write FFC Data to Device

- 1) When reading FFC data from the device or writing FFC data to the device, the FFC is enabled by default. After the read from the device is successful, the FFC takes effect in real time.
- 2) When writing to the device, the user set will be saved and the startup user set will be set to UserSet0.

#### 9.4.2.5. Load FFC Data from File / Save FFC Data to File

- 1) When loading FFC data from file or saving FFC data to file, the FFC is enabled by default. After the read from the device is successful, the FFC takes effect in real time.
- 2) When loading FFC data from file or saving FFC data to file, the default file path is: under the installation path (\*\GalaxySDK\Demo\Win64\resource\gxplugins\FlatFieldCorrection).



When loading from a file, only files with a format of .ffc can be opened.

### 9.4.3. Precautions

#### 9.4.3.1. FFC is not Supported

When the device does not support FFC, all widgets of the FFC plugin are disabled. The prompt box indicates that the device does not support FFC. Therefore, the FFC cannot be used for this device.

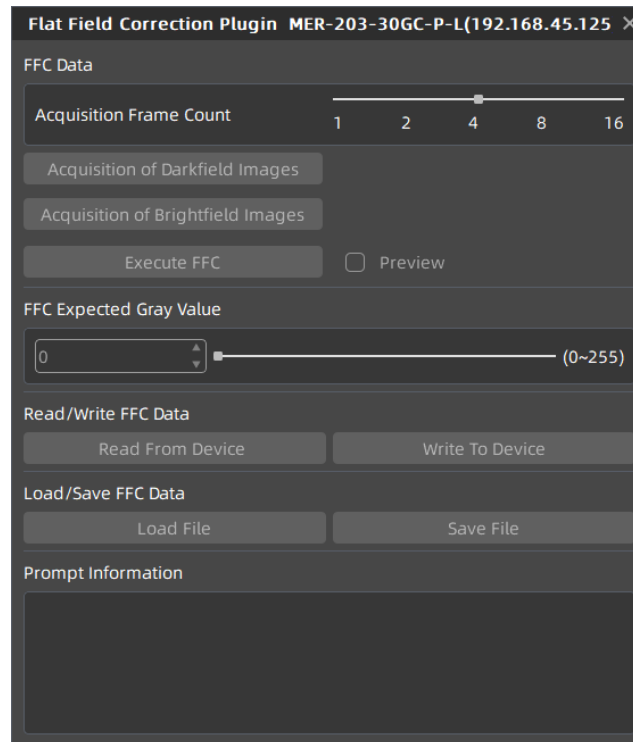

Figure 9-15 The camera does not support FFC

## 9.5. Static Defect Correction Plugin

Static Defect Correction Plugin support all series of DAHENG IMAGING camera. The plugin is integrated into GalaxyView.exe. After opening the device through GalaxyView, open the Static Defect Correction plugin from the menu bar plugin list. Using the plugin, you can achieve the following functions:

- 1) Analyze the defect pixel in the current images of the device, including Bright dark scene and Actual scene.
- 2) Execute Static Defect Correction on the images.
- 3) Save the defect pixel information to the device.(The camera which support Static Defect Correction)
- 4) Save the defect pixel information to the file

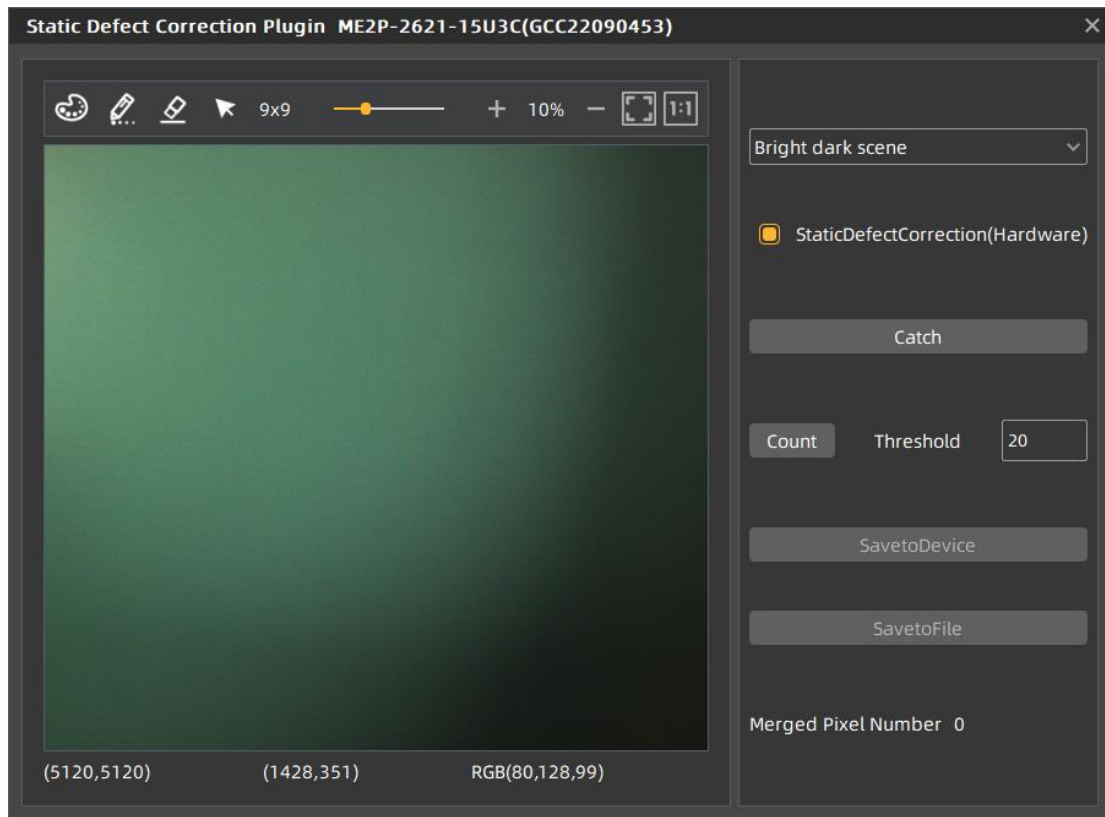

Figure 9-16 Static Defect Correction Plugin

After opening the device through GalaxyView.exe and opening the Static Defect Correction plugin, the initial state of the GUI is shown in Figure 9-16. The plugin layout and function description are as follows:

No.	Widget	Function
1	Catch	Acquisition an image to analyze the location of the defect pixels and noise points
2	Threshold	Set the threshold for defect pixels and noise points judgment
3	Bright dark scene	Count the defect pixels
4	Actual scene	Count the noise points
5	Count	Count the location of the defect pixels and noise points
6	StaticDefectCorrection (hardware)	Choose whether to perform Static Defect Correction
7	SavetoDevice	Save the defects information to the device
8	SavetoFile	Save the defects information to a file
9	Image display area	Display the image. After counting the defect pixels and noise points, the location of the defect/noise pixels will be marked on the displayed image
10	Merged pixel number	Display the number of defects









11		Change the color of merged pixels
12		Manually mark the defects on the image
13		Erase the original merged pixels on the image
14		Set mouse gestures as arrow
15		Change the size of merged pixels
16		Zoom in
17		Zoom out
18		Adaptive present image
19		Present image 100%

Table 9-3 Function description of the Static Defect Correction plugin

**[Image]** Capture an image through the catch button and display it in the white area in the middle of the plugin. The captured image is used to analyze the location of the defect pixels /noise points.

**[Defect pixel analysis]** User determines the range of defect pixels to be processed by setting the threshold and select the type of defect pixels. After clicking the "Count" button, the plugin will analyze the location of the defect pixels /noise points in the current image, and mark the location of the defect pixels on the image as red. The merged pixel number are display in the status bar.

If the current device supports the function of static defect pixel correction, and the merged pixel number is less than the number 8192 that the device supports. The defect pixel information will be written into the FLASH of the device.

**[Operation]** The Static Defect Correction can be performed by hardware or software. If the current device supports Static Defect Correction and the merged pixel number is less than 8192, hardware is preferred to perform Static Defect Correction, otherwise it can be executed through software. After the user check the Static Defect Correction box, the image displayed on GalaxyView is the image after performing the Static Defect Correction.

"SavetoDevice" button can save the defect pixel information to the FLASH of the device.

"SavetoFile" button can save the defect pixel information to .dp or .csv file.







**[Image display area]** Display the image and the location of the defect pixels /noise points.

**[Status bar]** Show the defect pixels number/noise points number/merged pixel number.

### 9.5.1. Static Defect Correction Steps

- 1) Click the "Catch" to capture an image. For details, please see section "Acquisition Images"
- 2) Set threshold to determine the range of defect pixels
- 3) Check "Bright dark scene" or "Actual scene" to select the type of defect pixels
- 4) Click "Count" to complete the defect pixel analysis. The location of the defect pixels on the image will be marked and displayed in the status bar
- 5) Check "StaticDefectCorrection" to execute Static Defect Correction
- 6) When the device supports Static Defect Correction and the merged number is less than 8192, the user can through the "Save to Device" to write the statistics of the defect pixel information into the device, and it will still be valid after power off and restart
- 7) The user can click the "Save to File" to save the statistics of defect pixel information to a file. For details, please see section "How to Use Defect Pixel Data File"

### 9.5.2. Acquisition Images

- 1) When the device is in the stop acquisition mode, click "Catch", the image will be displayed in the GalaxyView acquisition GUI.
- 2) When the device is in the acquisition mode, click "Catch" to complete the image acquisition.
- 3) When counting defect pixels, it is required to acquisition images with uniform gray scale. For example, use bright field images when detecting dark defect pixels, and use dark field images when detecting bright defect pixels.
- 4) When the threshold is fixed, the number of defect pixels will be affected by the exposure time and gain. The greater the value of exposure time and gain, the greater the number of defect pixels.
- 5) The counted defect pixels by the device under the maximum resolution are applicable to any ROI image. The counted defect pixels by the device in the ROI are only applicable to the image in the ROI.
- 6) Click "  " to select the manual mark color.
- 7) Click "  ", set the mouse gestures as pencil to mark the defects on the image.
- 8) Click "  " to erase the original merged pixels on the image.
- 9) Click "  " to zoom in the image.
- 10) Click "  " to zoom out the image.
- 11) Click "  " to adaptive present image.

- 12) Click "  " to present image 100%.
- 13) When performing image scaling operation, the current image scaling ratio will be displayed.
- 14) The current image width and height, pixel coordinates of mouse position and RGB value of mouse position are displayed in the status bar.

### 9.5.3. Static Defect Correction

- 1) "StaticDefectCorrection" is divided into "StaticDefectCorrection (software)" and "StaticDefectCorrection (hardware)"
- 2) When the device perform Static Defect Correction, the plugin will give priority to hardware to implement Static Defect Correction, which will be displayed as "StaticDefectCorrection (hardware)", otherwise it will be displayed as "StaticDefectCorrection (software)"
- 3) The condition for the device to perform Static Defect Correction is that the device supports the Static Defect Correction function and the number of defects is less than 8192.
- 4) When the device is in the acquisition mode, the user can check or uncheck "Static Defect Correction" to check the correction result.



When the device performs Static Dead Pixel Correction, it is temporarily unable to remove the dead pixels at the left and right boundaries. The monochrome camera is 3 pixels from the boundary, and the color camera is 6 pixels from the boundary.

### 9.5.4. How to Use Defect Pixel Data File

- 1) The format of the defect pixel data file is ".dp" and ".csv", and the default save path is under the installation package directory:  
\*\Daheng Imaging\GalaxySDK\Demo\Win64\resource\gxplugins\DefectPixelCorrection;

When you need to use the SDK to implement the Static Defect Correction function, you can read the saved defect pixel data file and call the function of the image processing library: DxStaticDefectPixelCorrection to realize the Static Defect Correction of the image.

## 9.6. Action Command Window

Users can use this tool to batch configure multiple cameras to receive operation commands. Firstly, set the action command information in the **Action Command Parameters** area, which can be manually entered or click **Auto Config** to set default parameters. After selecting **Auto Config start acquisition** option, the cameras' trigger source will be set to Action and start acquisition by clicking **Auto Config** button. Clicking **"Send Action Command"** will trigger the camera to capture an image.

- **Boot Mode**

Tool Bar (GalaxyView) → Tool → Action Command Window

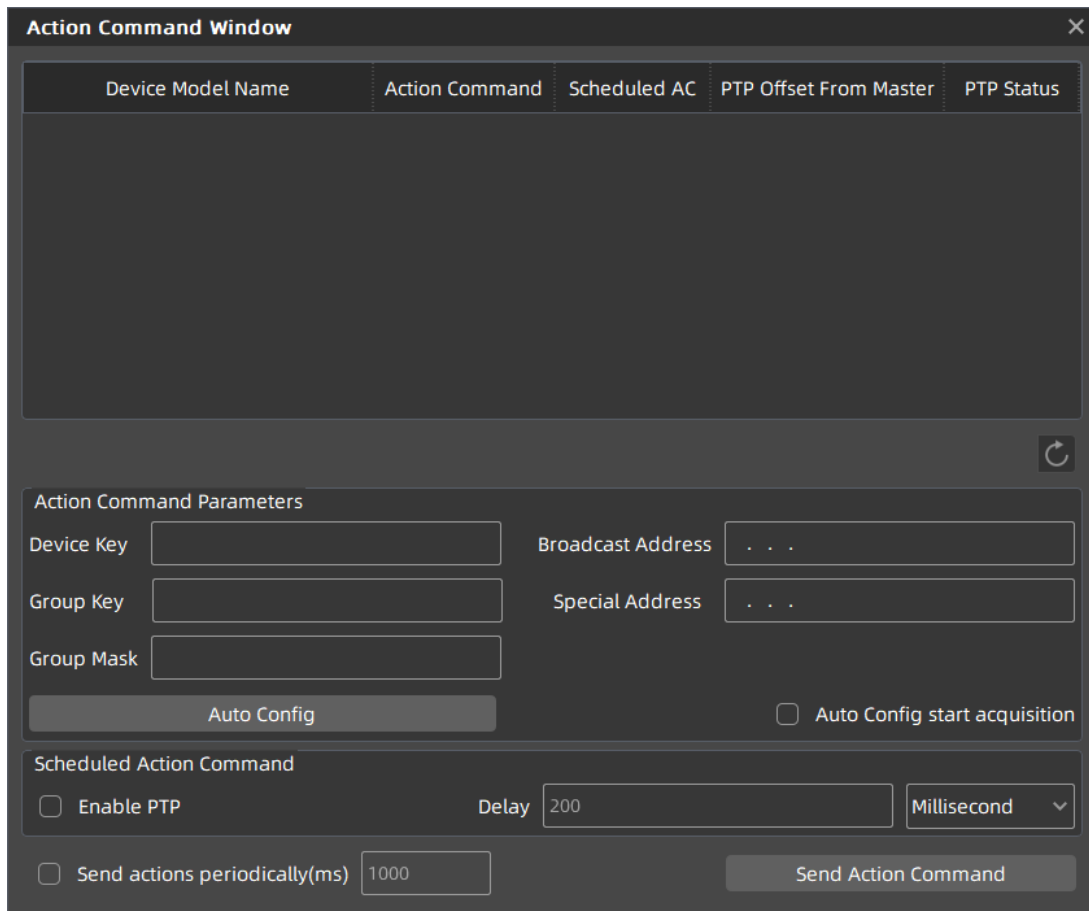

Figure 9-17 Action command window

The list at the top of the window displays all the opened cameras that are connected to your computer and support Action Command functionality. If there are no cameras in the list, please check in the device window if the connected cameras are opened and whether support this feature. If you add or remove any camera that supports Action Command function and is already open in the device window, it will be immediately reflected in the Action Command Window.

**Action Command Parameters:** You can manually input the required parameters or choose Auto Config. If you want to write this setting to the camera, please select Auto Config start acquisition and click Auto Config. This operation will continue until the camera is disconnected.

**Broadcast Address:** This parameter informs the computer where the Action command should be sent. The default is 255.255.255.255 (including all cameras connected to the computer). If you want to limit the number of cameras that can receive Action commands, you can specify a single subnet or specify a single camera.

**Special Address:** This parameter informs the computer from which network adapter IP the Action command should be sent. If not specified, each IP of all network adapters will send the current Action command.

The following three parameters are used to configure the camera, all using 32bit hexadecimal notation.

**Device Key:** This parameter is used to authorize the execution of action commands on the camera, corresponding to the "ActionDeviceKey" property of the device.

**Group Key:** This parameter is used to define a set of cameras on which Action commands can be executed, corresponding to the "ActionGroupKey" property of the device.

**Group Mask:** This parameter allows users to filter out a camera subgroup from the group defined by the Group Key, corresponding to the "ActionGroupMask" property of the device.

**Auto Config start acquisition:** After selecting this option, click Auto Config will enable batch acquisition of cameras that support Action.

**Auto Config:** Click Auto Config button will set the Device Key, Group Key, and Group Mask values to the camera, while setting the Trigger Mode to On and Trigger Source to Action0.

**Scheduled Action Command:** Users can specify the delay time for sending action commands. Check "Enable PTP" function for the devices in the list that support PTP Scheduled Action, and you can send the scheduled action command by entering the delay time.

**Send actions periodically (ms):** A timer will be activated every specific time (user input) to trigger the "Send Action Command" button to send actions.

## 10. FAQ

No.	General Question	Answer
1	No images after starting acquisition.	<ol style="list-style-type: none"> <li>1) Confirm that the camera packet size is greater than 1500, generally the packet size is set to be the maximum. If the host is not in jumbo frame mode, modify the maximum size of the IP packet to jumbo frame mode.</li> <li>2) Load the default parameter set, reopen the application program, and then start acquisition again.</li> <li>3) Run the demo program, and open the configuration page to confirm whether the data packet is received. If there are data packets, but they are all incomplete frames, please check your environment requirements in section 2.4.</li> </ol>
2	The frame rate is not up to the nominal value.	<ol style="list-style-type: none"> <li>1) Choose a better host.</li> <li>2) Choose a recommended Intel series Gigabit Network card.</li> <li>3) Contact with the technical support.</li> </ol>
3	Lose frames seriously in a multiple cameras' application.	<ol style="list-style-type: none"> <li>1) Adjust the packet size or packet delay, but frame rate reducing followed.</li> <li>2) Using multiple network cards, and the cameras are connected separately to different network cards.</li> </ol>
4	On the unactivated Windows7 64bit system, the installation of GalaxySDK has been successfully, but open the demo program failed.	<ol style="list-style-type: none"> <li>1) Activate Windows7 64bit system, uninstall the package. Then, reinstall the package after restarting the system, and reopen the demo program.</li> </ol>
5	Fail to open device, prompting the XML file parsing error.	<ol style="list-style-type: none"> <li>1) Contact with the technical support to obtain upgrade program, and then upgrade your cameras.</li> </ol>
6	Cannot receive any image after modifying the packet delay to a larger value.	<ol style="list-style-type: none"> <li>1) Confirm the data block timeout settings in the configuration page, and adjust the timeout settings until the image data is received.</li> </ol>
7	The cameras cannot be enumerated under Windows XP.	<ol style="list-style-type: none"> <li>1) Check if the network is connected.</li> <li>2) Enumerate repeatedly.</li> <li>3) Modify the host IP address, and enumerate once again. Make sure that the host IP address is not the same as the camera.</li> </ol>

No.	General Question	Answer
8	The device fails to start acquisition, and the "Attach Buffer fails" error occurs.	<p>1) Method 1: Modify the parameter of the stream layer <b>MaxNumQueueBuffer</b> (the maximum buffer number of acquisition queue) to be less than 9.</p> <p>The disadvantage of methods 1 is that the solution may reduce the acquisition performance, for the user who has low requirement of acquisition frame rate or the user who use trigger mode can select this way, but it is not recommended to the user who has high requirements of acquisition frame rate.</p> <p>2) Method 3: increase the physical memory size and replacing the 32bit system with a 64bit system, it is recommended to use windows7 or above, it is a good solution to this problem.</p>

## 11. Revision History

No.	Version	Changes	Date
1	V1.0.0	1. Initial release	2025-07-16
2	V1.0.1	1. Add VE2S-042-121GM/C-P, VE2S-161-75GM/C-P	2026-02-04

## 12. Contact Us

### 12.1. Contact Sales

If you need to order products or inquire product information, please contact our sales:

Tel: +86 10 8282 8878-8081

Email: [isales@daheng-imaging.com](mailto:isales@daheng-imaging.com)

### 12.2. Contact Support

If you have any questions in using DAHENG IMAGING products, please contact the experts on our support team:

Tel: +86 10 8282 887

Email: [isupport@daheng-imaging.com](mailto:isupport@daheng-imaging.com)